



Inverter 29900-40000 3 Phase

User Manual

Issue 01
Date 2023/30/08



Copyright © 2023 iStore tm

About This Document

Overview

This document describes the IS-INV-29900-3PH and IS-INV-40000-3PH (also referred to as ISTORE) in terms of their installation, electrical connections, commissioning, maintenance, and troubleshooting. Before installing and operating the ISTORE, ensure that you are familiar with the features, functions, and safety precautions provided in this document.





Intended Audience

This document is applicable to:

- Installers
- Users

Symbol Conventions

The symbols that may be found in this document are defined as follows.

Symbol	Description
 DANGER	Indicates a hazard with a high level of risk which, if not avoided, will result in death or serious injury.
 WARNING	Indicates a hazard with a medium level of risk which, if not avoided, could result in death or serious injury.
 CAUTION	Indicates a hazard with a low level of risk which, if not avoided, could result in minor or moderate injury.
 NOTICE	Indicates a potentially hazardous situation which, if not avoided, could result in equipment damage, data loss, performance deterioration, or unanticipated results. NOTICE is used to address practices not related to personal injury.
 NOTE	Supplements the important information in the main text. NOTE is used to address information not related to personal injury, equipment damage, and environment deterioration.

Change History

Changes between document issues are cumulative. The latest document issue contains all changes made in earlier issues.

Issue 01 (2023-07-30)

This issue is the first official release.

Contents

About This Document	i
1 Safety Information	1
1.1 Personal Safety	2
1.2 Electrical Safety	4
1.3 Environment Requirements.....	6
1.4 Mechanical Safety	8
2 Overview	12
2.1 Product Introduction	12
2.2 Appearance.....	14
2.3 Label Description	15
2.4 Working Principles	16
2.4.1 Circuit Diagram.....	16
2.4.2 Working Modes	17
3 ISTORE Storage	19
4 Installation	20
4.1 Checking Before Installation.....	20
4.2 Tool Preparation	21
4.3 Selecting an Installation Position	22
4.4 Moving the ISTORE.....	26
4.5 Installing the Mounting Bracket.....	27
4.5.1 Support-mounted Installation	28
4.5.2 Wall-mounted Installation	29
4.6 Installing an ISTORE	30
5 Electrical Connections	33
5.1 Precautions.....	33
5.2 Preparing Cables	34
5.3 Connecting the PE Cable	36
5.4 Connecting the AC Output Power Cable.....	38
5.5 Installing the DC Input Power Cable.....	44
5.5.1 Cable Connection Description.....	44
5.5.2 Connecting Cables to Amphenol Helios H4 Connectors.....	46
5.5.3 Connecting Cables to Staubli MC4 Connectors	47

5.6 (Optional) Installing the Smart Dongle.....	49
5.7 Connecting the Signal Cable.....	50
5.7.1 Communication Modes.....	52
5.7.2 (Optional) Connecting the RS485 Communications Cable to the ISTORE.....	52
5.7.3 (Optional) Connecting the RS485 Communications Cable to the Power Meter.....	53
5.7.4 (Optional) Connecting the Power Grid Scheduling Signal Cable.....	54
5.7.5 (Optional) Connecting the Rapid Shutdown Signal Cable.....	55
6 Commissioning.....	57
6.1 Checking Before Power-On.....	57
6.2 System Power-On.....	58
7 Man-Machine Interaction.....	60
7.1 App Commissioning.....	60
7.1.1 Downloading the HiSolar App.....	60
7.1.2 Connecting to the Inverter.....	60
7.1.3 Quick Settings.....	61
7.1.4 What Should I Do If the Device Is Disconnected from the App When I Switch the Local Commissioning Screen to the Background?.....	61
7.2 Parameters Settings.....	62
7.2.1 Energy Control.....	62
7.2.2 AFCI.....	67
7.2.3 DRM.....	68
8 Maintenance.....	70
8.1 System Power-Off.....	70
8.2 Routine Maintenance.....	71
8.3 Troubleshooting.....	72
9 Handling the Inverter.....	82
9.1 Removing the ISTORE.....	82
9.2 Packing the ISTORE.....	82
9.3 Disposing of the ISTORE.....	82
10 Technical Specifications.....	83
A Grid Codes.....	87
B Device Commissioning.....	89
C Setting Power Adjustment Parameters.....	90
D Rapid Shutdown.....	93
E Resetting Password.....	94
F Locating Insulation Resistance Faults.....	95
G Acronyms and Abbreviations.....	98

1 Safety Information

Statement

Before transporting, storing, installing, operating, using, and/or maintaining the equipment, read this document, strictly follow the instructions provided herein, and follow all the safety instructions on the equipment and in this document. In this document, "equipment" refers to the products, software, components, spare parts, and/or services related to this document; "the Company" refers to the manufacturer (producer), seller, and/or service provider of the equipment; "you" refers to the entity that transports, stores, installs, operates, uses, and/or maintains the equipment.

The **Danger, Warning, Caution, and Notice** statements described in this document do not cover all the safety precautions. You also need to comply with relevant international, national, or regional standards and industry practices. **The Company shall not be liable for any consequences that may arise due to violations of safety requirements or safety standards concerning the design, production, and usage of the equipment.**

The equipment should be used in an environment that meets the design specifications. Otherwise, the equipment may be faulty, malfunctioning, or damaged, which is not covered under the warranty. The Company shall not be liable for any property loss, personal injury, or even death caused thereby.

Comply with applicable laws, regulations, standards, and specifications during transportation, storage, installation, operation, use, and maintenance.

Do not perform reverse engineering, decompilation, disassembly, adaptation, implantation, or other derivative operations on the equipment software. Do not study the internal implementation logic of the equipment, obtain the source code of the equipment software, violate intellectual property rights, or disclose any of the performance test results of the equipment software.

The Company shall not be liable for any of the following circumstances or their consequences:

- The equipment is damaged due to force majeure such as earthquakes, floods, volcanic eruptions, debris flows, lightning strikes, fires, wars, armed conflicts, typhoons, hurricanes, tornadoes, and other extreme weather conditions.
- The equipment is operated beyond the conditions specified in this document.
- The equipment is installed or used in environments that do not comply with international, national, or regional standards.
- The equipment is installed or used by unqualified personnel.

- You fail to follow the operation instructions and safety precautions on the product and in the document.
- You remove or modify the product or modify the software code without authorization.
- You or a third party authorized by you cause the equipment damage during transportation.
- The equipment is damaged due to storage conditions that do not meet the requirements specified in the product document.
- You fail to prepare materials and tools that comply with local laws, regulations, and related standards.
- The equipment is damaged due to your or a third party's negligence, intentional breach, gross negligence, or improper operations, or other reasons not related to the Company.

1.1 Personal Safety

 DANGER

Ensure that power is off during installation. Do not install or remove a cable with power on. Transient contact between the core of the cable and the conductor will generate electric arcs or sparks, which may cause a fire or personal injury.

 DANGER

Non-standard and improper operations on the energized equipment may cause fire, electric shocks, or explosion, resulting in property damage, personal injury, or even death.

 DANGER

Before operations, remove conductive objects such as watches, bracelets, bangles, rings, and necklaces to prevent electric shocks.

 DANGER

During operations, use dedicated insulated tools to prevent electric shocks or short circuits. The dielectric withstanding voltage level must comply with local laws, regulations, standards, and specifications.

 WARNING

During operations, wear personal protective equipment such as protective clothing, insulated shoes, goggles, safety helmets, and insulated gloves.

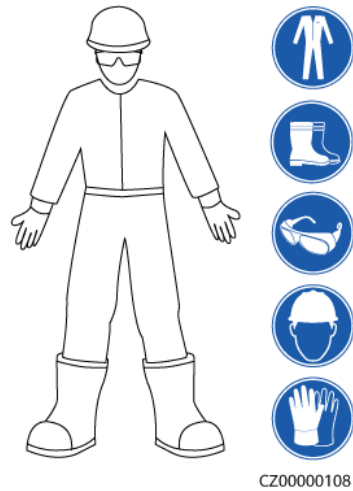
Figure 1-1 Personal protective equipment

General Requirements

- Do not stop protective devices. Pay attention to the warnings, cautions, and related precautionary measures in this document and on the equipment.
- If there is a likelihood of personal injury or equipment damage during operations, immediately stop, report the case to the supervisor, and take feasible protective measures.
- Do not power on the equipment before it is installed or confirmed by professionals.
- Do not touch the power supply equipment directly or with conductors such as damp objects. Before touching any conductor surface or terminal, measure the voltage at the contact point to ensure that there is no risk of electric shock.
- Do not touch operating equipment because the enclosure is hot.
- Do not touch a running fan with your hands, components, screws, tools, or boards. Otherwise, personal injury or equipment damage may occur.
- In the case of a fire, immediately leave the building or the equipment area and activate the fire alarm or call emergency services. Do not enter the affected building or equipment area under any circumstances.

Personnel Requirements

- Only professionals and trained personnel are allowed to operate the equipment.
 - Professionals: personnel who are familiar with the working principles and structure of the equipment, trained or experienced in equipment operations and are clear of the sources and degree of various potential hazards in equipment installation, operation, maintenance
 - Trained personnel: personnel who are trained in technology and safety, have required experience, are aware of possible hazards on themselves in certain operations, and are able to take protective measures to minimize the hazards on themselves and other people
- Personnel who plan to install or maintain the equipment must receive adequate training, be able to correctly perform all operations, and understand all necessary safety precautions and local relevant standards.

- Only qualified professionals or trained personnel are allowed to install, operate, and maintain the equipment.
- Only qualified professionals are allowed to remove safety facilities and inspect the equipment.
- Personnel who will perform special tasks such as electrical operations, working at heights, and operations of special equipment must possess the required local qualifications.
- Only authorized professionals are allowed to replace the equipment or components (including software).
- Only personnel who need to work on the equipment are allowed to access the equipment.

1.2 Electrical Safety

 DANGER

Before connecting cables, ensure that the equipment is intact. Otherwise, electric shocks or fire may occur.

 DANGER

Non-standard and improper operations may result in fire or electric shocks.

 DANGER

Prevent foreign matter from entering the equipment during operations. Otherwise, equipment damage, load power derating, power failure, or personal injury may occur.

 WARNING

For the equipment that needs to be grounded, install the ground cable first when installing the equipment and remove the ground cable last when removing the equipment.

 CAUTION

Do not route cables near the air intake or exhaust vents of the equipment.

General Requirements

- Follow the procedures described in the document for installation, operation, and maintenance. Do not reconstruct or alter the equipment, add components, or change the installation sequence without permission.

- Obtain approval from the national or local electric utility company before connecting the equipment to the grid.
- Observe the power plant safety regulations, such as the operation and work ticket mechanisms.
- Install temporary fences or warning ropes and hang "No Entry" signs around the operation area to keep unauthorized personnel away from the area.
- Before installing or removing power cables, turn off the switches of the equipment and its upstream and downstream switches.
- Before performing operations on the equipment, check that all tools meet the requirements and record the tools. After the operations are complete, collect all of the tools to prevent them from being left inside the equipment.
- Before installing power cables, check that cable labels are correct and cable terminals are insulated.
- When installing the equipment, use a torque tool of a proper measurement range to tighten the screws. When using a wrench to tighten the screws, ensure that the wrench does not tilt and the torque error does not exceed 10% of the specified value.
- Ensure that bolts are tightened with a torque tool and marked in red and blue after double-check. Installation personnel mark tightened bolts in blue. Quality inspection personnel confirm that the bolts are tightened and then mark them in red. (The marks should cross the edges of the bolts.)

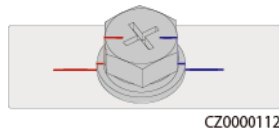

- If the equipment has multiple inputs, disconnect all the inputs before operating the equipment.
- Before maintaining a downstream electrical or power distribution device, turn off the output switch on the power supply equipment.
- During equipment maintenance, attach "Do not switch on" labels near the upstream and downstream switches or circuit breakers as well as warning signs to prevent accidental connection. The equipment can be powered on only after troubleshooting is complete.
- Do not open equipment panels.
- Check equipment connections periodically, ensuring that all screws are securely tightened.
- Only qualified professionals can replace a damaged cable.
- Do not scrawl, damage, or block any labels or nameplates on the equipment. Promptly replace labels that have worn out.
- Do not use solvents such as water, alcohol, or oil to clean electrical components inside or outside of the equipment.

Grounding

- Ensure that the grounding impedance of the equipment complies with local electrical standards.
- Ensure that the equipment is connected permanently to the protective ground. Before operating the equipment, check its electrical connection to ensure that it is reliably grounded.
- Do not work on the equipment in the absence of a properly installed ground conductor.
- Do not damage the ground conductor.

Cabling Requirements

- When selecting, installing, and routing cables, follow local safety regulations and rules.
- When routing power cables, ensure that there is no coiling or twisting. Do not join or weld power cables. If necessary, use a longer cable.
- Ensure that all cables are properly connected and insulated, and meet specifications.
- Ensure that the slots and holes for routing cables are free from sharp edges, and that the positions where cables are routed through pipes or cable holes are equipped with cushion materials to prevent the cables from being damaged by sharp edges or burrs.
- Ensure that cables of the same type are bound together neatly and straight and that the cable sheath is intact. When routing cables of different types, ensure that they are away from each other without entanglement and overlapping.
- Secure buried cables using cable supports and cable clips. Ensure that the cables in the backfill area are in close contact with the ground to prevent cable deformation or damage during backfilling.
- If the external conditions (such as the cable layout or ambient temperature) change, verify the cable usage in accordance with the IEC-60364-5-52 or local laws and regulations. For example, check that the current-carrying capacity meets requirements.
- When routing cables, reserve at least 30 mm clearance between the cables and heat-generating components or areas. This prevents deterioration or damage to the cable insulation layer.

1.3 Environment Requirements

 DANGER

Do not expose the equipment to flammable or explosive gas or smoke. Do not perform any operation on the equipment in such environments.

 DANGER

Do not store any flammable or explosive materials in the equipment area.

 DANGER

Do not place the equipment near heat sources or fire sources, such as smoke, candles, heaters, or other heating devices. Overheat may damage the equipment or cause a fire.

⚠ WARNING

Install the equipment in an area far away from liquids. Do not install it under areas prone to condensation, such as under water pipes and air exhaust vents, or areas prone to water leakage, such as air conditioner vents, ventilation vents, or feeder windows of the equipment room. Ensure that no liquid enters the equipment to prevent faults or short circuits.

⚠ WARNING

To prevent damage or fire due to high temperature, ensure that the ventilation vents or heat dissipation systems are not obstructed or covered by other objects while the equipment is running.

General Requirements

- Ensure that the equipment is stored in a clean, dry, and well ventilated area with proper temperature and humidity and is protected from dust and condensation.
- Keep the installation and operating environments of the equipment within the allowed ranges. Otherwise, its performance and safety will be compromised.
- Do not install, use, or operate outdoor equipment and cables (including but not limited to moving equipment, operating equipment and cables, inserting connectors to or removing connectors from signal ports connected to outdoor facilities, working at heights, performing outdoor installation, and opening doors) in harsh weather conditions such as lightning, rain, snow, and level 6 or stronger wind.
- Do not install the equipment in an environment with dust, smoke, volatile or corrosive gases, infrared and other radiations, organic solvents, or salty air.
- Do not install the equipment in an environment with conductive metal or magnetic dust.
- Do not install the equipment in an area conducive to the growth of microorganisms such as fungus or mildew.
- Do not install the equipment in an area with strong vibration, noise, or electromagnetic interference.
- Ensure that the site complies with local laws, regulations, and related standards.
- Ensure that the ground in the installation environment is solid, free from spongy or soft soil, and not prone to subsidence. The site must not be located in a low-lying land prone to water or snow accumulation, and the horizontal level of the site must be above the highest water level of that area in history.
- Do not install the equipment in a position that may be submerged in water.
- If the equipment is installed in a place with abundant vegetation, in addition to routine weeding, harden the ground underneath the equipment using cement or gravel (recommended area: 3 m x 2.5 m).
- Do not install the equipment outdoors in salt-affected areas because it may be corroded. A salt-affected area refers to the region within 500 m of the coast or prone to sea breeze. Regions prone to sea breeze vary with weather conditions (such as typhoons and monsoons) or terrains (such as dams and hills).
- Before opening doors during the installation, operation, and maintenance of the equipment, clean up any water, ice, snow, or other foreign objects on the top of the equipment to prevent foreign objects from falling into the equipment.

- When installing the equipment, ensure that the installation surface is solid enough to bear the weight of the equipment.
- After installing the equipment, remove the packing materials such as cartons, foam, plastics, and cable ties from the equipment area.

1.4 Mechanical Safety

⚠ WARNING

Ensure that all necessary tools are ready and inspected by a professional organization. Do not use tools that have signs of scratches or fail to pass the inspection or whose inspection validity period has expired. Ensure that the tools are secure and not overloaded.

⚠ WARNING

Do not drill holes into the equipment. Doing so may affect the sealing performance and electromagnetic containment of the equipment and damage components or cables inside. Metal shavings from drilling may short-circuit boards inside the equipment.

General Requirements

- Repaint any paint scratches caused during equipment transportation or installation in a timely manner. Equipment with scratches cannot be exposed for an extended period of time.
- Do not perform operations such as arc welding and cutting on the equipment without evaluation by the Company.
- Do not install other devices on the top of the equipment without evaluation by the Company.
- When performing operations over the top of the equipment, take measures to protect the equipment against damage.
- Use correct tools and operate them in the correct way.

Moving Heavy Objects

- Be cautious to prevent injury when moving heavy objects.



< 18 kg
(< 40 lbs)



18-32 kg
(40-70 lbs)



32-55 kg
(70-121 lbs)

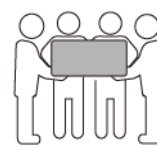

55-68 kg
(121-150 lbs)



> 68 kg
(> 150 lbs)

CZ0000110

- If multiple persons need to move a heavy object together, determine the manpower and work division with consideration of height and other conditions to ensure that the weight is equally distributed.

- If two persons or more move a heavy object together, ensure that the object is lifted and landed simultaneously and moved at a uniform pace under the supervision of one person.
- Wear personal protective gears such as protective gloves and shoes when manually moving the equipment.
- To move an object by hand, approach to the object, squat down, and then lift the object gently and stably by the force of the legs instead of your back. Do not lift it suddenly or turn your body around.
- Do not quickly lift a heavy object above your waist. Place the object on a workbench that is half-waist high or any other appropriate place, adjust the positions of your palms, and then lift it.
- Move a heavy object stably with balanced force at an even and low speed. Put down the object stably and slowly to prevent any collision or drop from scratching the surface of the equipment or damaging the components and cables.
- When moving a heavy object, be aware of the workbench, slope, staircase, and slippery places. When moving a heavy object through a door, ensure that the door is wide enough to move the object and avoid bumping or injury.
- When transferring a heavy object, move your feet instead of turning your waist around. When lifting and transferring a heavy object, ensure that your feet point to the target direction of movement.
- When transporting the equipment using a pallet truck or forklift, ensure that the tynes are properly positioned so that the equipment does not topple. Before moving the equipment, secure it to the pallet truck or forklift using ropes. When moving the equipment, assign dedicated personnel to take care of it.
- Choose sea or roads in good conditions for transportation as transportation by railway or air is not supported. Avoid tilt or jolt during transportation.

Using Ladders

- Use wooden or insulated ladders when you need to perform live-line working at heights.
- Platform ladders with protective rails are preferred. Single ladders are not recommended.
- Before using a ladder, check that it is intact and confirm its load bearing capacity. Do not overload it.
- Ensure that the ladder is securely positioned and held firm.



CZ00000107

- When climbing up the ladder, keep your body stable and your center of gravity between the side rails, and do not overreach to the sides.
- When a step ladder is used, ensure that the pull ropes are secured.
- If a single ladder is used, the recommended angle for the ladder against the floor is 75 degrees, as shown in the following figure. A square can be used to measure the angle.

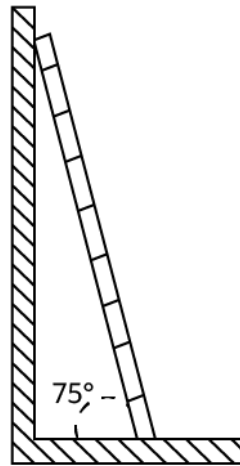

PI02SC0008

- If a single ladder is used, ensure that the wider end of the ladder is at the bottom, and take protective measures to prevent the ladder from sliding.
- If a single ladder is used, do not climb higher than the fourth rung of the ladder from the top.
- If you use a single ladder to climb up to a platform, ensure that the ladder is at least 1 m higher than the platform.

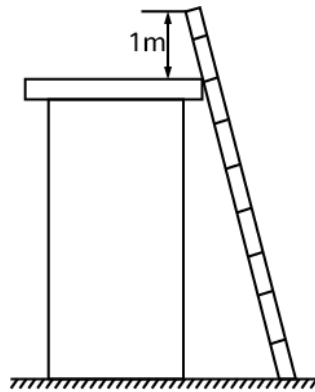

PI02SC0009

Hoisting

- Only trained and qualified personnel are allowed to perform hoisting operations.
- Install temporary warning signs or fences to isolate the hoisting area.
- Ensure that the foundation where hoisting is performed on meets the load-bearing requirements.
- Before hoisting objects, ensure that hoisting tools are firmly secured onto a fixed object or wall that meets the load-bearing requirements.
- During hoisting, do not stand or walk under the crane or the hoisted objects.
- Do not drag steel ropes and hoisting tools or bump the hoisted objects against hard objects during hoisting.
- Ensure that the angle between two hoisting ropes is no more than 90 degrees, as shown in the following figure.

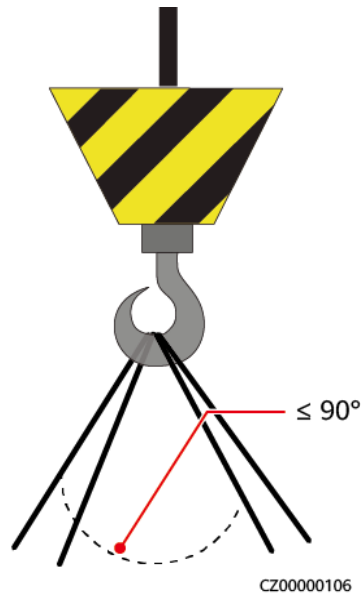

Drilling Holes

- Obtain consent from the customer and contractor before drilling holes.
- Wear protective equipment such as safety goggles and protective gloves when drilling holes.
- To avoid short circuits or other risks, do not drill holes into buried pipes or cables.
- When drilling holes, protect the equipment from shavings. After drilling, clean up any shavings.

2 Overview

2.1 Product Introduction

Function

The ISTORE inverter is a three-phase grid-tied PV string inverter that converts the DC power generated by PV strings into AC power and feeds the power into the power grid.

Model

This document covers the following ISTORE models:

- IS-INV-29900-3PH
- IS-INV-40000-3PH

Networking Application

The ISTORE applies to the grid-tied systems of industrial and commercial rooftops and small ground PV plants. Typically, a grid-tied system consists of PV strings, grid-tied inverters, AC switches, and power distribution units.

Figure 2-1 Networking application - single inverter scenario

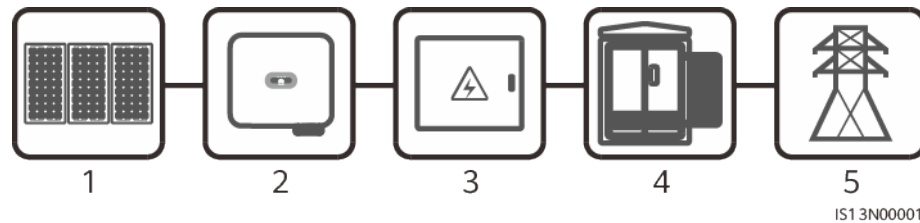

- | | | |
|---------------------------|----------------|--------------------------------|
| (1) PV string | (2) ISTORE | (3) AC power distribution unit |
| (4) Isolation transformer | (5) Power grid | |

Supported Power Grid Types

The ISTORE supports TN-S, TN-C, TN-C-S, TT, and IT power grids.

Figure 2-2 Power grid types

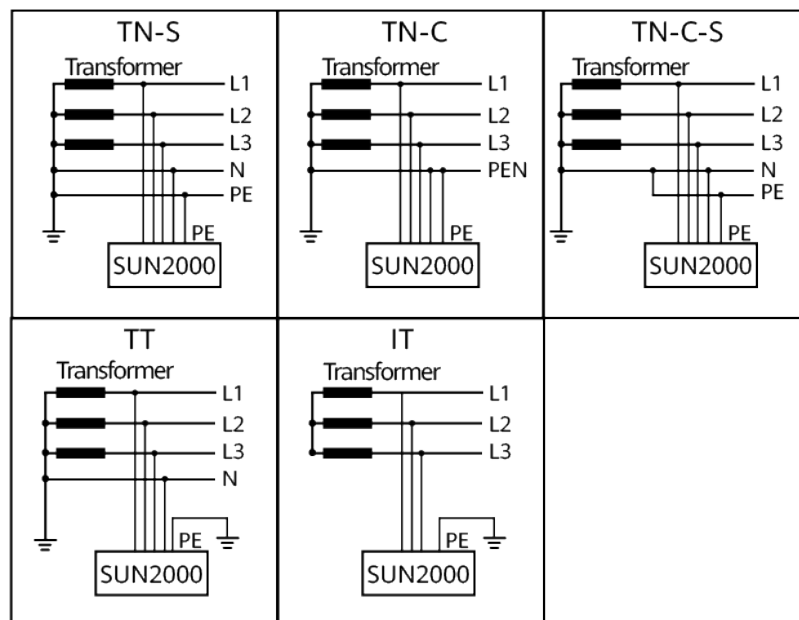

IS01S10001

2.2 Appearance

Figure 2-3 Appearance

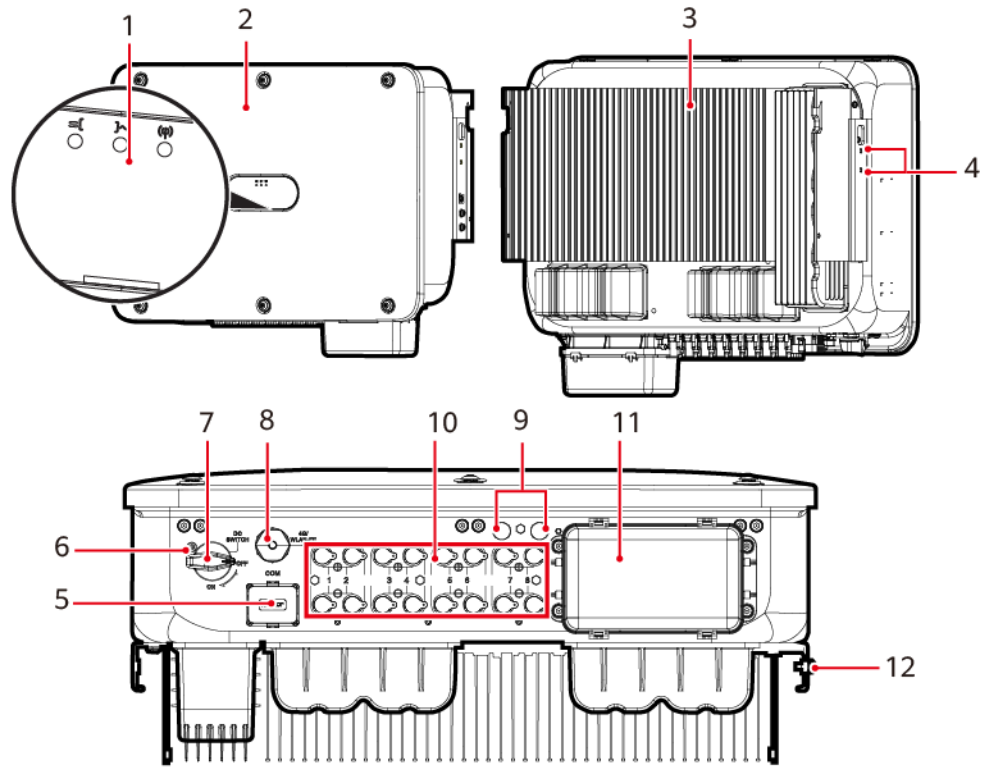



IS13W00001

- | | |
|-------------------------------|--|
| (1) LED indicator | (2) Front panel |
| (3) Heat sink | (4) Screws for fixing the awning |
| (5) Communications port (COM) | (6) Hole for the DC switch locking screw |
| (7) DC switch (DC SWITCH) | (8) Smart Dongle port (WLAN-FE) |
| (9) Ventilation valve | (10) DC input terminals (PV1-PV8) |
| (11) AC output port | (12) Ground point |

2.3 Label Description

Enclosure Labels

Symbol	Name	Description
	Delay discharge	Residual voltage exists after the ISTORE is powered off. It takes 5 minutes for the ISTORE to discharge to the safe voltage.
	Burn warning	Do not touch a running ISTORE because it generates high temperatures on the shell.
	Electric shock warning	<ul style="list-style-type: none"> High voltage exists after the ISTORE is powered on. Only qualified and trained electrical technicians are allowed to perform operations on the ISTORE. High touch current exists after the ISTORE is powered on. Before powering on the ISTORE, ensure that the ISTORE is properly grounded.
	Refer to documentation	Reminds operators to refer to the documents delivered with the ISTORE.
	Grounding label	Indicates the position for connecting the PE cable.
	Operation warning	Do not remove the DC input connector or AC output connector with power on.
	Weight label	The ISTORE is heavy and needs to be carried by three persons.

Symbol	Name	Description																																													
	Burn warning on inverter handles	Do not touch the handles within 10 minutes after the inverter is shut down.																																													
<table border="1"> <thead> <tr> <th colspan="2">运行指示 Running indication</th> <th>指示定义 Meaning</th> </tr> <tr> <th>LED 1</th> <th>LED 2</th> <th></th> </tr> </thead> <tbody> <tr> <td>绿色常亮 Steady green</td> <td>绿色常亮 Steady green</td> <td>并网 Exporting power to the power grid</td> </tr> <tr> <td>绿色慢闪 Blinking green at long intervals</td> <td>灭 Off</td> <td>直流上电且交流未上电 DC on and AC off</td> </tr> <tr> <td>绿色慢闪 Blinking green at long intervals</td> <td>绿色慢闪 Blinking green at long intervals</td> <td>直流上电且交流上电（未并网） DC on and AC on (no power to the power grid)</td> </tr> <tr> <td>灭 Off</td> <td>绿色慢闪 Blinking green at long intervals</td> <td>直流未上电且交流上电 DC off and AC on</td> </tr> <tr> <td>灭 Off</td> <td>灭 Off</td> <td>直流未上电且交流未上电 DC off and AC off</td> </tr> <tr> <td>红色快闪 Blinking red at short intervals</td> <td>N/A</td> <td>直流侧环境告警 DC environmental alarm</td> </tr> <tr> <td>N/A</td> <td>红色快闪 Blinking red at short intervals</td> <td>交流侧环境告警 AC environmental alarm</td> </tr> <tr> <td>红色常亮 Steady red</td> <td>红色常亮 Steady red</td> <td>故障 Fault</td> </tr> </tbody> </table> <table border="1"> <thead> <tr> <th colspan="2">通讯指示 Communication indication</th> <th>指示定义 Meaning</th> </tr> <tr> <th>LED 3</th> <th></th> <th></th> </tr> </thead> <tbody> <tr> <td>绿色快闪 Blinking green at short intervals</td> <td></td> <td>通讯中 Communicating</td> </tr> <tr> <td>绿色慢闪 Blinking green at long intervals</td> <td></td> <td>手机接入 Connected to the mobile phone</td> </tr> <tr> <td>灭 Off</td> <td></td> <td>其他 Others</td> </tr> </tbody> </table>	运行指示 Running indication		指示定义 Meaning	LED 1	LED 2		绿色常亮 Steady green	绿色常亮 Steady green	并网 Exporting power to the power grid	绿色慢闪 Blinking green at long intervals	灭 Off	直流上电且交流未上电 DC on and AC off	绿色慢闪 Blinking green at long intervals	绿色慢闪 Blinking green at long intervals	直流上电且交流上电（未并网） DC on and AC on (no power to the power grid)	灭 Off	绿色慢闪 Blinking green at long intervals	直流未上电且交流上电 DC off and AC on	灭 Off	灭 Off	直流未上电且交流未上电 DC off and AC off	红色快闪 Blinking red at short intervals	N/A	直流侧环境告警 DC environmental alarm	N/A	红色快闪 Blinking red at short intervals	交流侧环境告警 AC environmental alarm	红色常亮 Steady red	红色常亮 Steady red	故障 Fault	通讯指示 Communication indication		指示定义 Meaning	LED 3			绿色快闪 Blinking green at short intervals		通讯中 Communicating	绿色慢闪 Blinking green at long intervals		手机接入 Connected to the mobile phone	灭 Off		其他 Others	Indicator	Indicates the ISTORE operating information.
运行指示 Running indication		指示定义 Meaning																																													
LED 1	LED 2																																														
绿色常亮 Steady green	绿色常亮 Steady green	并网 Exporting power to the power grid																																													
绿色慢闪 Blinking green at long intervals	灭 Off	直流上电且交流未上电 DC on and AC off																																													
绿色慢闪 Blinking green at long intervals	绿色慢闪 Blinking green at long intervals	直流上电且交流上电（未并网） DC on and AC on (no power to the power grid)																																													
灭 Off	绿色慢闪 Blinking green at long intervals	直流未上电且交流上电 DC off and AC on																																													
灭 Off	灭 Off	直流未上电且交流未上电 DC off and AC off																																													
红色快闪 Blinking red at short intervals	N/A	直流侧环境告警 DC environmental alarm																																													
N/A	红色快闪 Blinking red at short intervals	交流侧环境告警 AC environmental alarm																																													
红色常亮 Steady red	红色常亮 Steady red	故障 Fault																																													
通讯指示 Communication indication		指示定义 Meaning																																													
LED 3																																															
绿色快闪 Blinking green at short intervals		通讯中 Communicating																																													
绿色慢闪 Blinking green at long intervals		手机接入 Connected to the mobile phone																																													
灭 Off		其他 Others																																													
<table border="1"> <tr> <td>(1)PN/ITEM:XXXXXXXX</td> <td></td> </tr> <tr> <td>(32P)MODEL.EESOLAR-XXKTL-XX</td> <td></td> </tr> <tr> <td>(S)SN:XXXXXXXXXXXX</td> <td>MADE IN CHINA</td> </tr> </table>	(1)PN/ITEM:XXXXXXXX		(32P)MODEL.EESOLAR-XXKTL-XX		(S)SN:XXXXXXXXXXXX	MADE IN CHINA	ISTORE serial number	Indicates the serial number.																																							
(1)PN/ITEM:XXXXXXXX																																															
(32P)MODEL.EESOLAR-XXKTL-XX																																															
(S)SN:XXXXXXXXXXXX	MADE IN CHINA																																														
WLAN SSID: EESOLAR-XXXXXXXXXX Password:XXXXXXXX 	ISTORE Wi-Fi login QR code	Scan the QR code to connect to the ISTORE Wi-Fi network.																																													

2.4 Working Principles

2.4.1 Circuit Diagram

An ISTORE can connect to a maximum of eight PV strings and has four MPPT circuits inside. Each MPPT circuit tracks the maximum power point of two PV strings. The ISTORE converts DC power into single-phase AC power through an inverter circuit. Surge protection is supported on both the DC and AC sides.

Figure 2-4 Schematic diagram

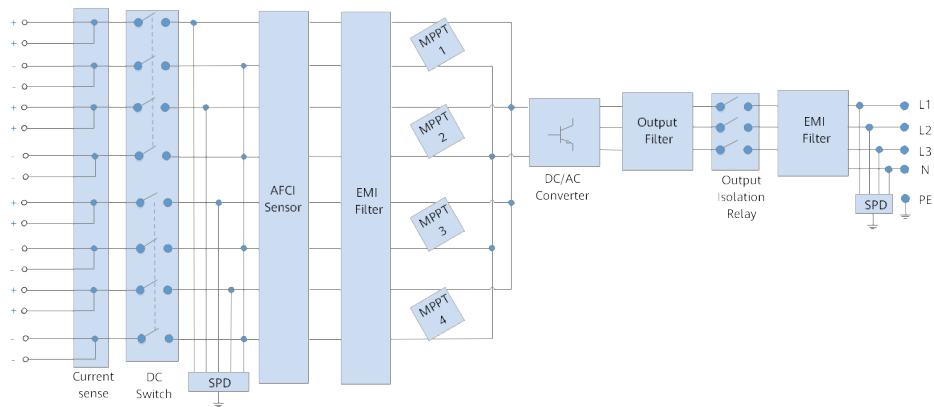

2.4.2 Working Modes

The ISTORE can work in Standby, Operating, or Shutdown mode.

Figure 2-5 Working modes

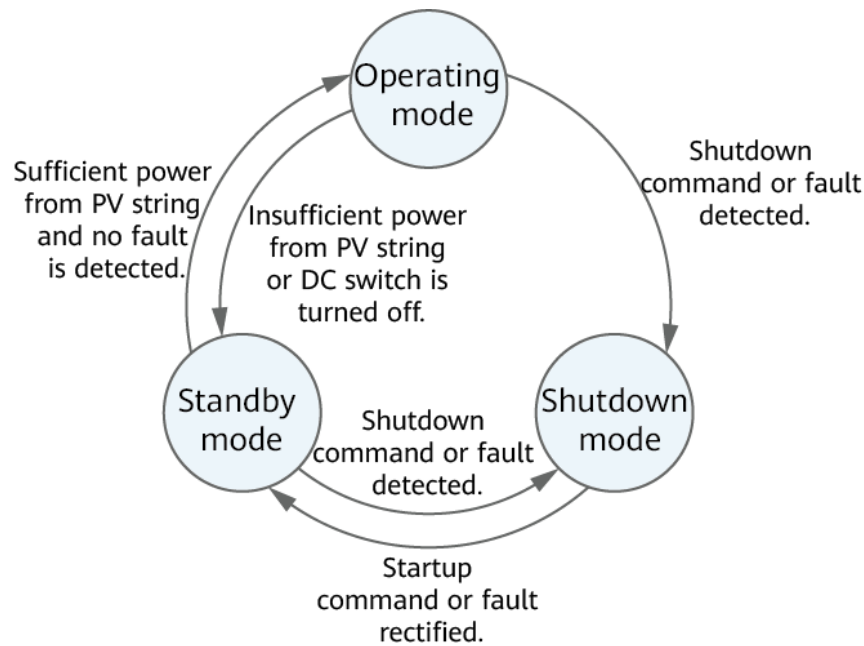

IS07500001

Table 2-1 Working mode description

Working Mode	Description
Standby	The ISTORE enters Standby mode when the external environment does not meet the operating requirements. In Standby mode:

Working Mode	Description
	<ul style="list-style-type: none"> • The ISTORE continuously performs status check and enters the Operating mode once the operating requirements are met. • The ISTORE enters Shutdown mode after detecting a shutdown command or a fault after startup.
Operating	<p>In Operating mode:</p> <ul style="list-style-type: none"> • The ISTORE converts DC power from PV strings into AC power and feeds the power to the power grid. • The ISTORE tracks the maximum power point to maximize the PV string output. • If the ISTORE detects a fault or a shutdown command, it enters the Shutdown mode. • The ISTORE enters Standby mode after detecting that the PV string output power is not suitable for connecting to the power grid for generating power.
Shutdown	<ul style="list-style-type: none"> • In Standby or Operating mode, the ISTORE enters Shutdown mode after detecting a fault or shutdown command. • In Shutdown mode, the ISTORE enters Standby mode after detecting a startup command or that the fault is rectified.

3 ISTORE Storage

The following requirements should be met if the ISTORE is not put into use directly:

- Do not unpack the ISTORE.
- Keep the storage temperature at -40°C to $+70^{\circ}\text{C}$ and the humidity at 5%–95% RH.
- Store the ISTORE in a clean and dry place and protect it from dust and water vapor corrosion.
- A maximum of six ISTOREs can be stacked. To avoid personal injury or device damage, stack ISTOREs with caution to prevent them from falling over.
- During the storage period, check the ISTORE periodically (recommended: every three months). If any rodent bites are found on the packing materials, replace the packing materials immediately.
- If the ISTORE has been stored for more than two years, it must be checked and tested by professionals before being put into use.

4 Installation

4.1 Checking Before Installation

Outer Packing Materials

Before unpacking the inverter, check the outer packing materials for damage, such as holes and cracks, and check the inverter model. If any damage is found or the inverter model is not what you requested, do not unpack the package and contact your supplier as soon as possible.

 **NOTE**

You are advised to remove the packing materials within 24 hours before installing the inverter.

Package Contents

NOTICE











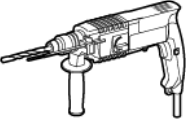

- After placing the equipment in the installation position, unpack it with care to prevent scratches. Keep the equipment stable during unpacking.
-



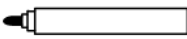
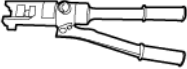

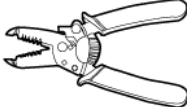
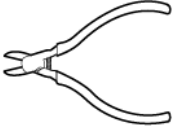
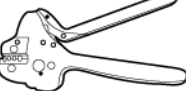

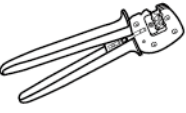

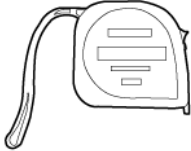

After unpacking the inverter, check that the contents are intact and complete. If any damage is found or any component is missing, contact your supplier.

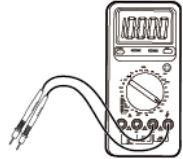
 **NOTE**

For details about the number of contents, see the *Packing List* in the packing case.

4.2 Tool Preparation

Type	Tools and Instruments		
Installation	 <p>Insulated torque socket wrench (including an extension bar)</p>	 <p>Insulated torque socket wrench (including an extended socket)</p>	 <p>Phillips insulated torque screwdriver</p>
	 <p>Hammer drill</p>	 <p>Drill bit</p>	 <p>Rubber mallet</p>
	 <p>Utility knife</p>	 <p>Marker</p>	 <p>Hydraulic pliers</p>
	 <p>Cable cutter</p>	 <p>Wire stripper</p>	 <p>Diagonal pliers</p>
	 <p>Crimping tool H4TC0003 (Amphenol)</p>	 <p>Open-end wrench H4TW0001 (Amphenol)</p>	 <p>Heat shrink tubing</p>
	 <p>Crimping tool (model: PV-)</p>	 <p>Open-end wrench (model: PV-)</p>	

Type	Tools and Instruments		
	CZM-22100)	MS-HZ or PV-MS open-end wrench)	Heat gun
			
	Steel measuring tape	Level	Multimeter
			-
	Cable tie	Vacuum cleaner	
Personal protective equipment (PPE)			
	Goggles	Work shoes	Dust mask
			-
	Protective gloves	Insulated gloves	

4.3 Selecting an Installation Position

Basic Requirements

- The ISTORE is IP66-rated and can be installed indoors or outdoors.
- Do not install the ISTORE in a place where a person can easily be exposed to its enclosure and heat sinks, because these parts are extremely hot during operation.
- Do not install the ISTORE in areas with flammable or explosive materials.
- If inverters are installed in a place with abundant vegetation, in addition to routine weeding, harden the ground underneath the inverters using cement or gravel (recommended area: 3 m x 2.5 m).
- Do not install the ISTORE in a place within children's reach.

- The ISTORE will be corroded in salt areas, and the salt corrosion may cause fire. Do not install the ISTORE outdoors in salt areas. A salt area refers to the region within 500 m from the coast or prone to sea breeze. The effect from sea breeze depends on weather conditions (such as typhoon and season wind) or terrains (such as dams and hills).

Site Requirements

- The ISTORE should be installed in a well-ventilated environment to ensure good heat dissipation.
- If the ISTORE is installed in a place exposed to direct sunlight, the power may decrease as the temperature rises.
- You are advised to install the ISTORE in a sheltered place or install an awning over it.

Mounting Structure Requirements

- The mounting structure where the ISTORE is installed must be fire resistant.
- Do not install the ISTORE on flammable building materials.
- The ISTORE is heavy. Ensure that the installation surface is solid enough to bear the weight load.
- In residential areas, do not install the ISTORE on drywalls or walls made of similar materials which have a weak sound insulation performance because the noise generated by the ISTORE is noticeable.

Installation Angle Requirements

The ISTORE can be wall-mounted or support-mounted. Requirements for the installation angle:

- Install the ISTORE vertically or at a maximum back tilt of 15 degrees to facilitate heat dissipation.
- Do not install the ISTORE with a front tilt, excessive back tilt, side tilt, horizontally, or upside down.

Figure 4-1 Installation angle

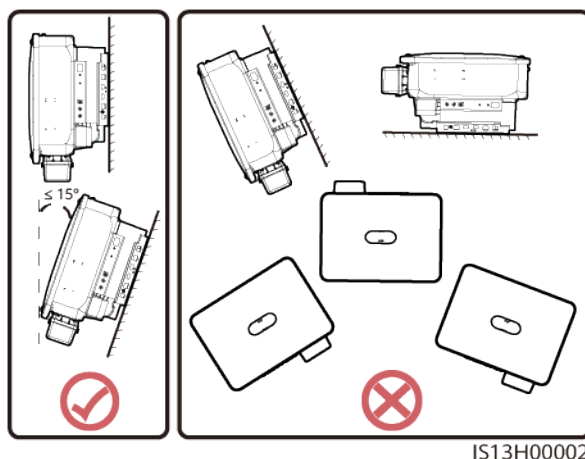

IS13H00002

Installation Space Requirements

- Reserve enough clearance around the ISTORE to ensure sufficient space for installation and heat dissipation.

Figure 4-2 Installation space

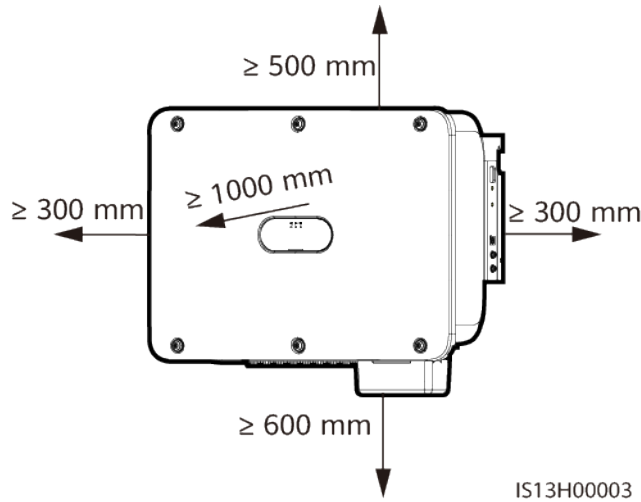

- When installing multiple ISTOREs, install them in horizontal mode if ample space is available and install them in triangle mode if no ample space is available. Stacked installation is not recommended.

Figure 4-3 Horizontal installation (recommended)

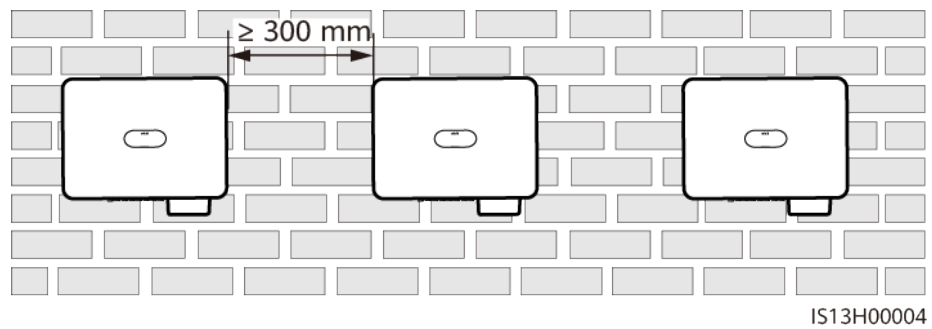

Figure 4-4 Two-layer triangle installation (recommended)

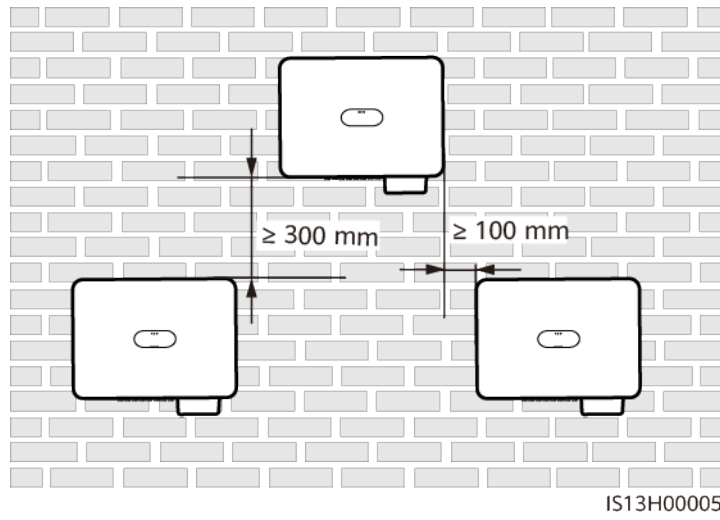

Figure 4-5 Three-layer triangle installation (not recommended)

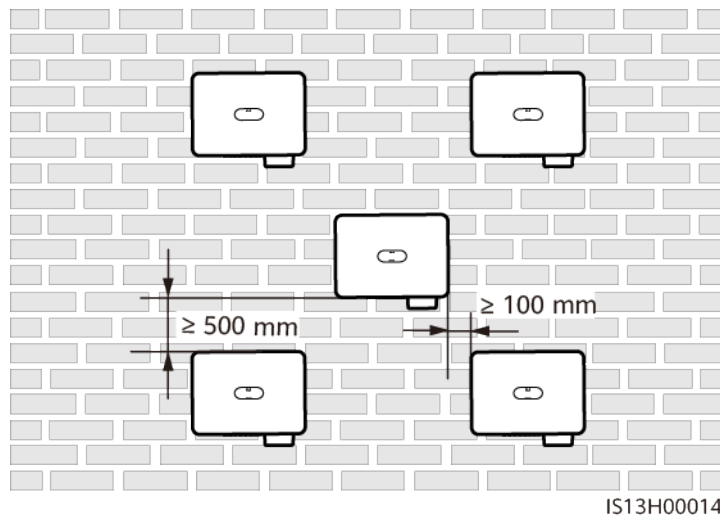

Figure 4-6 Stacked installation (not recommended)

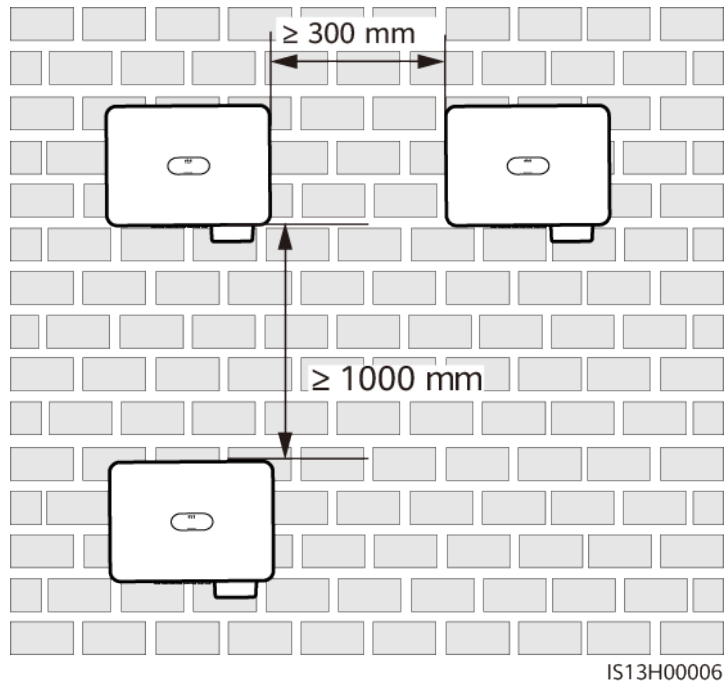
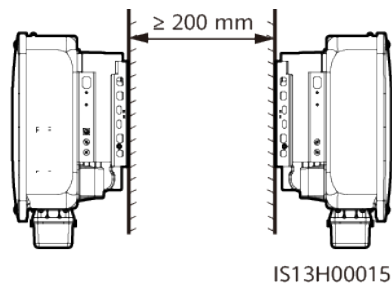

Figure 4-7 Back-to-back installation (not recommended)



NOTE

The installation diagrams are for reference only and are irrelevant to the ISTORE cascading scenario.

4.4 Moving the ISTORE

NOTICE

- After placing the equipment in the installation position, unpack it with care to prevent scratches. Keep the equipment stable during unpacking.

Procedure

Step 1 Lift the ISTORE from the packing case and move it to the specified installation position.

CAUTION

- Move the ISTORE with care to prevent device damage and personal injury.
- Do not use the wiring terminals and ports at the bottom to support any weight of the ISTORE.
- Place a foam pad or cardboard under the ISTORE to protect the ISTORE enclosure from damage.

Figure 4-8 Moving the ISTORE

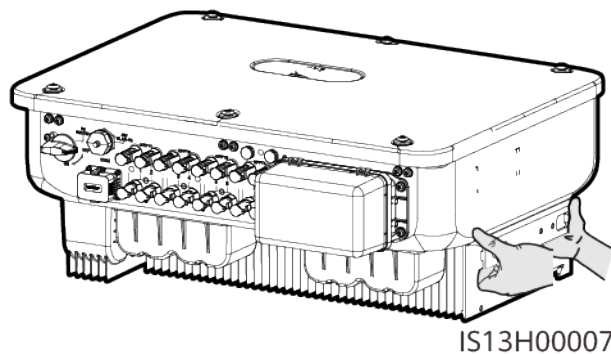

---End

4.5 Installing the Mounting Bracket

Installation Precautions

Before installing the mounting bracket, remove the security Torx wrench and set it aside.

Figure 4-9 Position for binding the security Torx wrench



(1) Security Torx wrench

Figure 4-10 shows the dimensions of the mounting holes for the ISTORE.

Figure 4-10 Mounting bracket dimensions

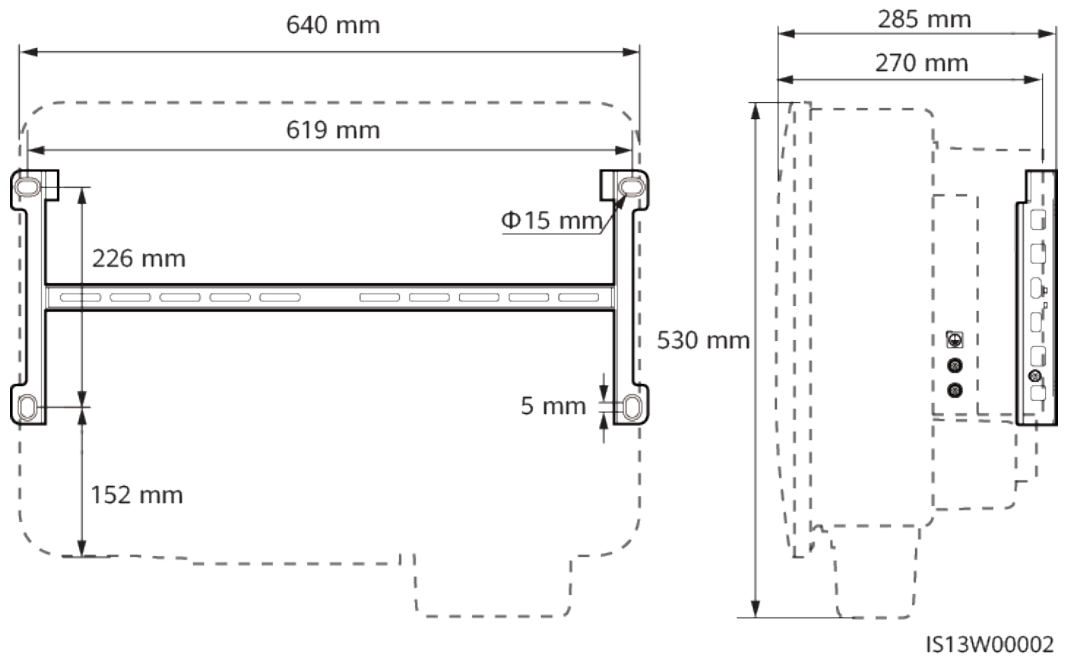

4.5.1 Support-mounted Installation

Procedure

Step 1 Secure the mounting bracket.

Figure 4-11 Securing the mounting bracket

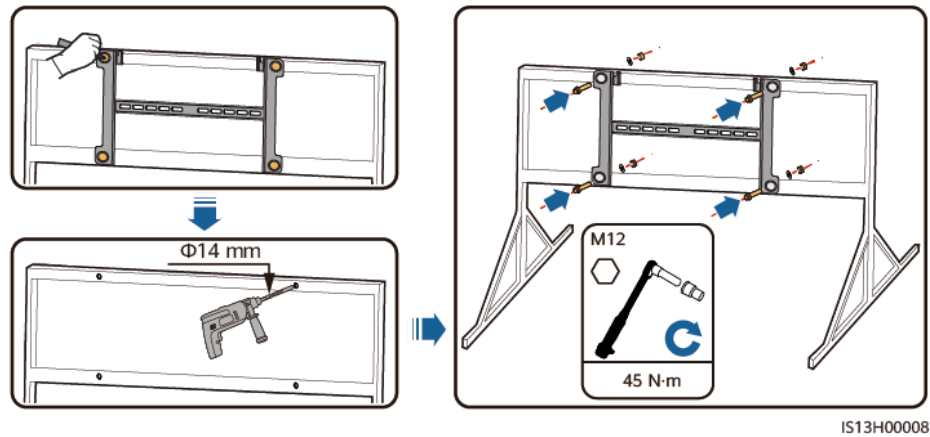

NOTE

You are advised to apply anti-rust paint on the hole positions for protection.

---End

4.5.2 Wall-mounted Installation

Prerequisites

To install the ISTORE, you need to prepare expansion bolts. M12x60 stainless steel expansion bolts are recommended.

Procedure

- Step 1** Determine the positions for drilling holes and mark the positions using a marker.
- Step 2** Secure the mounting bracket.

⚠ DANGER

Avoid drilling holes in the water pipes and cables buried in the wall.

Figure 4-12 Expansion bolt composition

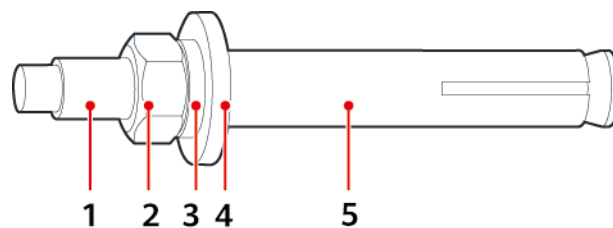

IS05W00018

- (1) Bolt
- (2) Nut
- (3) Spring washer
- (4) Flat washer
- (5) Expansion sleeve

NOTICE

- To prevent dust inhalation or contact with eyes, wear safety goggles and an anti-dust mask when drilling holes.
- Clean up any dust in and around the holes using a vacuum cleaner and measure the distance between holes. If the holes are inaccurately positioned, drill holes again.
- Level the front of the expansion sleeve with the concrete wall after removing the bolt, spring washer, and flat washer. Otherwise, the mounting bracket will not be securely installed on the concrete wall.

Figure 4-13 Installing expansion bolts

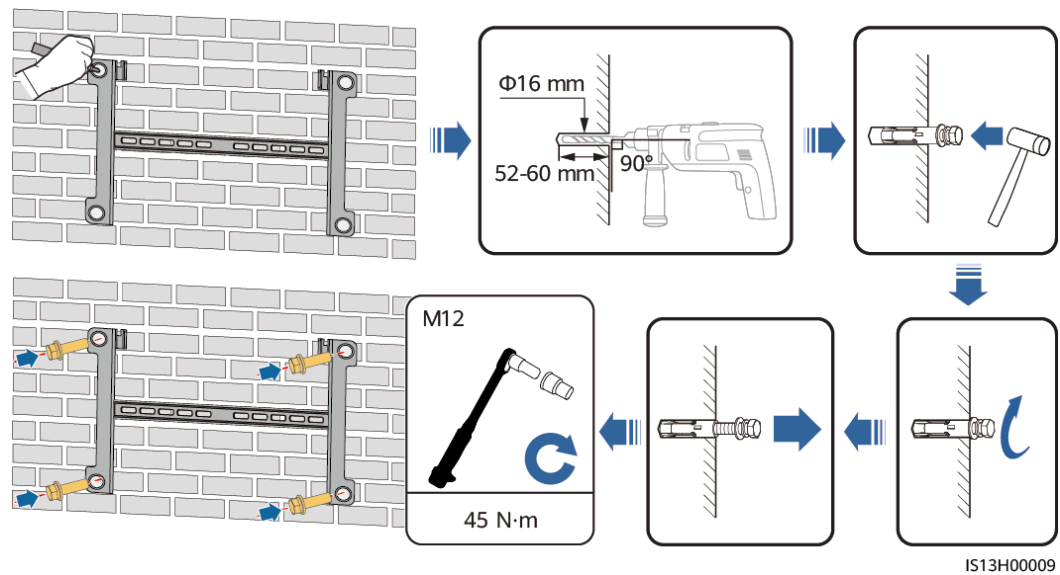

IS13H00009

----End

4.6 Installing an ISTORE

Step 1 (Optional) Install the locking screw for the DC switch.

NOTE

- The DC switch locking screw is used to lock the DC switch to prevent the switch from rotating.
- For models used in Australia, install the DC switch locking screw according to local standards. The DC switch locking screw is delivered with the ISTORE.

Figure 4-14 Installing the locking screw for the DC switch

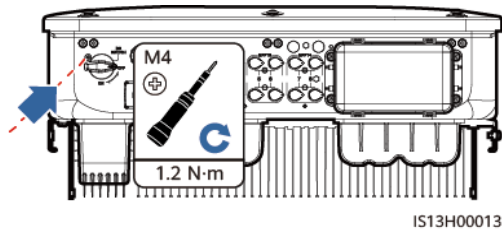

Step 2 Install the ISTORE onto the mounting bracket.

Figure 4-15 Installing an ISTORE

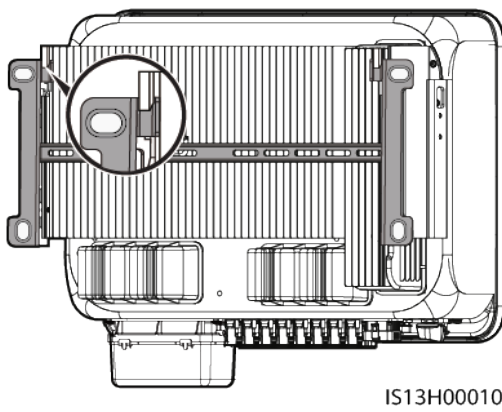

Step 3 Tighten the nuts on both sides of the ISTORE.

Figure 4-16 Tightening the nut

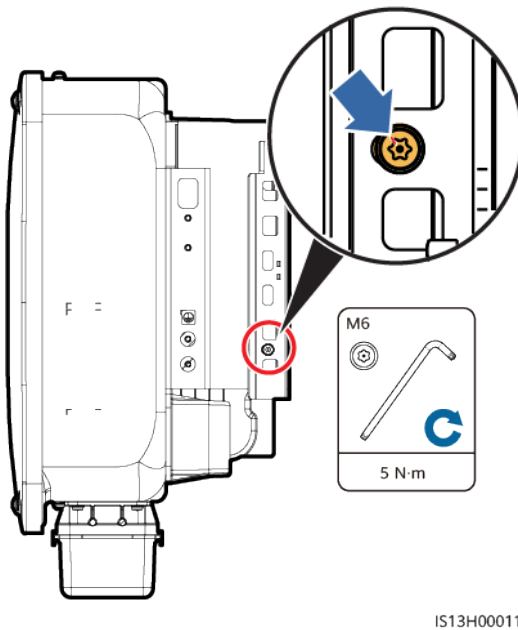

NOTICE

Secure the screws on the sides before connecting cables.

---**End**

5 Electrical Connections

5.1 Precautions

 DANGER

When exposed to sunlight, the PV arrays supply DC voltage to the inverter. Before connecting cables, ensure that all **DC SWITCH** on the inverter are OFF. Otherwise, the high voltage of the inverter may result in electric shocks.

 DANGER

- The site must be equipped with qualified fire fighting facilities, such as fire sand and carbon dioxide fire extinguishers.
 - Wear personal protective equipment and use dedicated insulated tools to avoid electric shocks or short circuits.
-

 WARNING

- The equipment damage caused by incorrect cable connections is beyond the warranty scope.
 - Only certified electrician can perform electrical terminations.
 - Operation personnel must wear PPE when connecting cables.
 - Before connecting cables to ports, leave enough slack to reduce the tension on the cables and prevent poor cable connections.
-

CAUTION

- Stay away from the equipment when preparing cables to prevent cable scraps from entering the equipment. Cable scraps may cause sparks and result in personal injury and equipment damage.
- When routing PV cables, the positive and negative PV string cables should be routed in different pipes to prevent cable damage and short circuits caused by improper operations during construction.

NOTE

The cable colors shown in the electrical connection diagrams provided in this section are for reference only. Select cables in accordance with local cable specifications (green-and-yellow cables are only used for protective earthing).

5.2 Preparing Cables

Figure 5-1 ISTORE cable connections (dashed boxes indicate optional components)

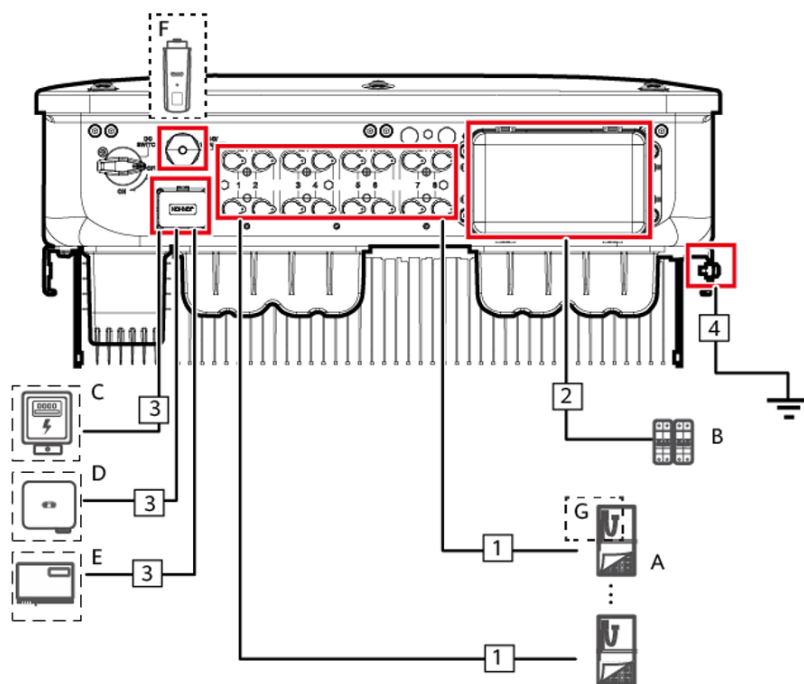

Table 5-1 Components

No.	Component	Description	Source
A	PV string	<ul style="list-style-type: none"> • A PV string consists of PV modules connected in series. • The ISTORE supports the input from eight PV strings. 	Prepared by users

No.	Component	Description	Source
B	AC switch	To ensure that the inverter can be safely disconnected from the power grid when an exception occurs, connect an AC switch to the AC side of the inverter. Select an appropriate AC switch in accordance with local industry standards and regulations. ISTORE recommends the following switch specifications: Recommended: a three-phase AC circuit breaker with a rated voltage greater than or equal to 500 V AC and a rated current of: <ul style="list-style-type: none"> • 63 A (IS-INV-29900-3PH) • 100 A (IS-INV-40000-3PH) 	Prepared by users
C	Power meter ^[1]	The ISTORE can connect to the DTSU666-HW, YDS60-80 and power meter.	Purchased from a third-party
D	ISTORE	Select a proper model as required.	Purchased from ISTORE
E	IS-LOGGER	IS-LOGGER3000	Purchased from ISTORE
F	Smart Dongle	Smart WLAN-FE Dongle	Purchased from ISTORE
G	PV optimizer	The inverter supports compatible 3rd party PV optimizer. Please consult with your dealer or ISTORE Energy for compatible models.	Purchased from provider
Note [1]: For details about meter operations, see DTSU666-HW Smart Power Sensor Quick Guide , YDS60-80 Smart Power Sensor Quick Guide .			

NOTICE

The cable specifications must comply with local standards.

Table 5-2 Cable description

No.	Cable	Type	Recommended Specifications	Source
1	DC input power cable	Common PV cable in the industry (Recommended model: PV1-F)	<ul style="list-style-type: none"> • Conductor cross-sectional area: 4–6 mm² • Cable outer diameter: 5.5–9 mm 	Prepared by users

No.	Cable	Type	Recommended Specifications	Source
2	AC output power cable	Outdoor copper-core/aluminum-core cable	<ul style="list-style-type: none"> Conductor cross-sectional area: 16-50 mm² outdoor copper-core cable or 35-50 mm² outdoor aluminum-core cable Cable outer diameter: 16–38 mm 	Prepared by users
3	(Optional) Signal cable	Two-core outdoor shielded twisted pair (recommended model: DJYP2VP2-2x2x0.75)	<ul style="list-style-type: none"> Conductor cross-sectional area: 0.2–1 mm² Cable outer diameter: 4–11 mm 	Prepared by users
4	PE cable	Single-core outdoor copper-core cable	Conductor cross-sectional area ≥ 16 mm ²	Prepared by users

Note a: Five-core cables with a cross-sectional area of 5 x 35 mm² or 5 x 50 mm² are not supported.

NOTICE

If the ISTORE is used with a 3rd party optimizer, route the AC and DC power cables separate to avoid interference to the communication of the 3rd party optimizer.

5.3 Connecting the PE Cable

DANGER

- Ensure that the PE cable is securely connected. Otherwise, electric shocks may occur.
- Do not connect the neutral wire to the enclosure as a PE cable. Otherwise, electric shocks may occur.

NOTE

- The PE point at the AC output port is used only as a PE equipotential point, not a substitute for the PE point on the enclosure.
- It is recommended that silicone sealant or paint be applied around the ground terminal after the PE cable is connected.

Procedure

Step 1 Crimp OT terminals.

NOTICE

- Avoid scratching the core wire when stripping a cable.
- The cavity formed after the conductor crimp strip of the OT terminal is crimped must wrap the core wires completely. The core wires must contact the OT terminal closely.
- Wrap the wire crimping area with heat shrink tubing or PVC insulation tape. The heat shrink tubing is used as an example.
- When using a heat gun, protect devices from being scorched.

Figure 5-2 Crimping an OT terminal

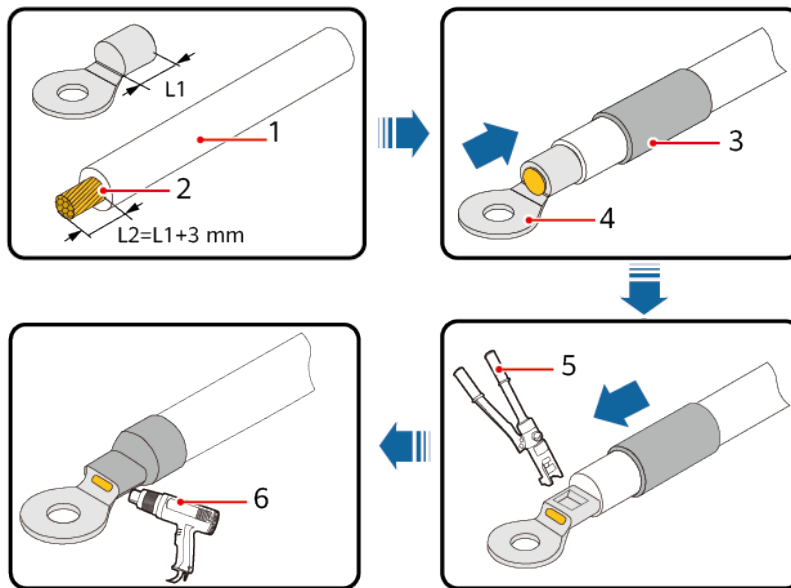

- | | | |
|-----------------|-------------------|------------------------|
| (1) Cable | (2) Core | (3) Heat shrink tubing |
| (4) OT terminal | (5) Crimping tool | (6) Heat gun |

Step 2 Connect the PE cable.

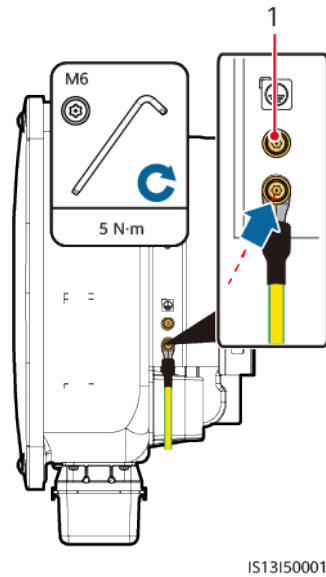
Figure 5-3 Connecting the PE cable

(1) Reserved PE point

---End

5.4 Connecting the AC Output Power Cable

Precautions

An AC switch must be installed on the AC side of the ISTORE to ensure that the ISTORE can be safely disconnected from the power grid.

WARNING

- Do not connect loads between the inverter and the AC switch that directly connects to the inverter. Otherwise, the switch may trip by mistake.
- If an AC switch is used with specifications beyond local standards, regulations, or the recommendations, the switch may fail to turn off in a timely manner in case of exceptions, causing serious faults.

CAUTION

Each inverter must be equipped with an AC output switch. Multiple inverters cannot connect to the same AC output switch.

NOTICE

- If the external AC switch can perform earth leakage protection, the rated leakage action current should be greater than or equal to 300 mA.
 - If multiple ISTOREs connect to the general residual current device (RCD) through their respective external AC switches, the rated leakage action current of the general RCD should be greater than or equal to the number of ISTOREs multiplied by 300 mA. (Type A RCD rating at 300A is Recommended.)
 - Use a socket wrench and extension rod to connect the AC power cable. The extension rod must be longer than 100 mm.
 - Sufficient slack should be provided in the PE cable to ensure that the last cable bearing the force is the PE cable when the AC output power cable bears pulling force due to force majeure.
 - Do not install third-party devices in the AC connection box.
 - You need to prepare M8 OT terminals by yourself.
-

Requirements for the OT or DT Terminal

- If a copper cable is used, use copper wiring terminals.
- If a copper-clad aluminum cable is used, use copper wiring terminals.
- If an aluminum alloy cable is used, use copper-aluminum transition wiring terminals, or aluminum wiring terminals along with copper-aluminum transition spacers.

NOTICE

- Do not connect aluminum wiring terminals to the AC terminal block. Otherwise the electrochemical corrosion will occur and affect the reliability of cable connections.
- Comply with the IEC61238-1 requirements when using copper-aluminum transition wiring terminals, or aluminum wiring terminals along with copper-aluminum transition spacers.
- If copper-aluminum transition spacers are used, pay attention to the front and rear sides. Ensure that the aluminum sides of spacers are in contact with aluminum wiring terminals, and copper sides of spacers are in contact with the AC terminal block.

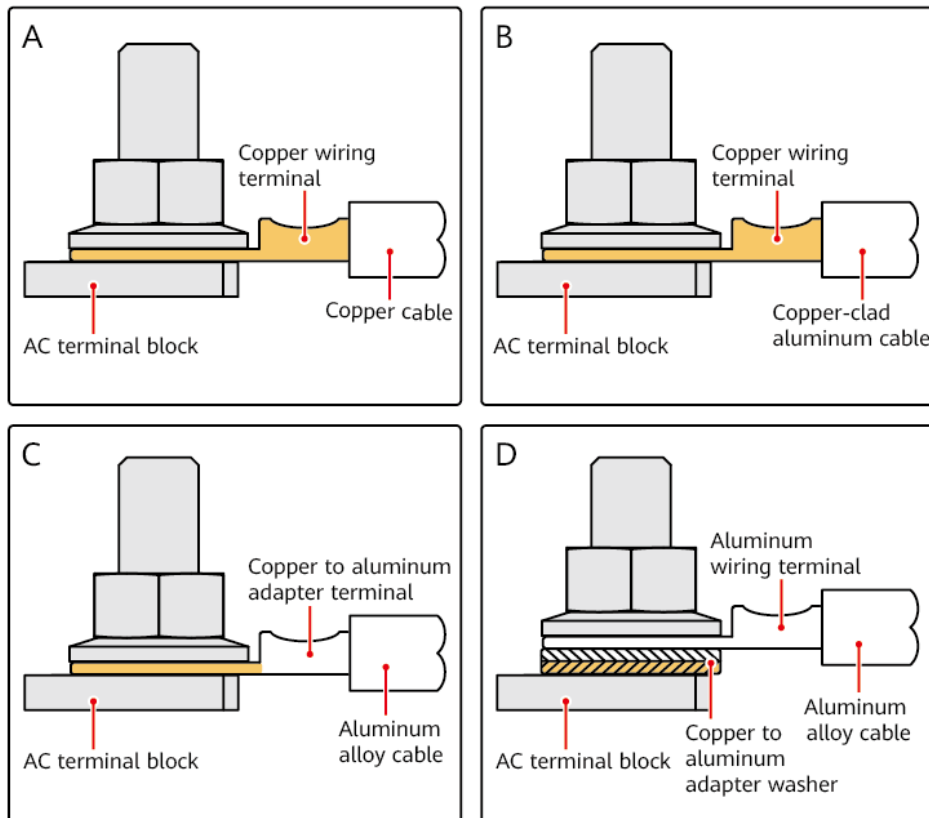
Figure 5-4 Requirements for the OT/DT terminal

IS03H00062

Procedure

- Step 1** Remove the AC terminal box and install partition boards.

Figure 5-5 Removing the AC terminal box

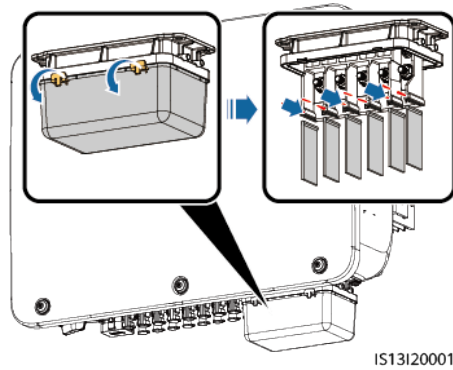

Step 2 Connect the AC output power cable.

NOTE

- To avoid damaging the rubber liner, do not route a cable with a crimped OT terminal directly through it.
- It is recommended that the length of the PE cable to be stripped be 15 mm longer than the length of other cables.
- The cable colors in figures are for reference only. Select appropriate cables according to the local standards.

Figure 5-6 Stripping the AC power cable (using a five-core cable as an example)

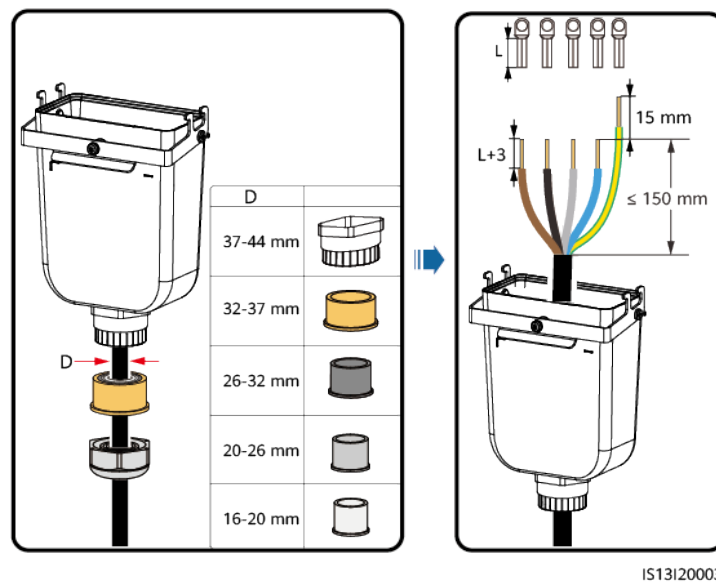
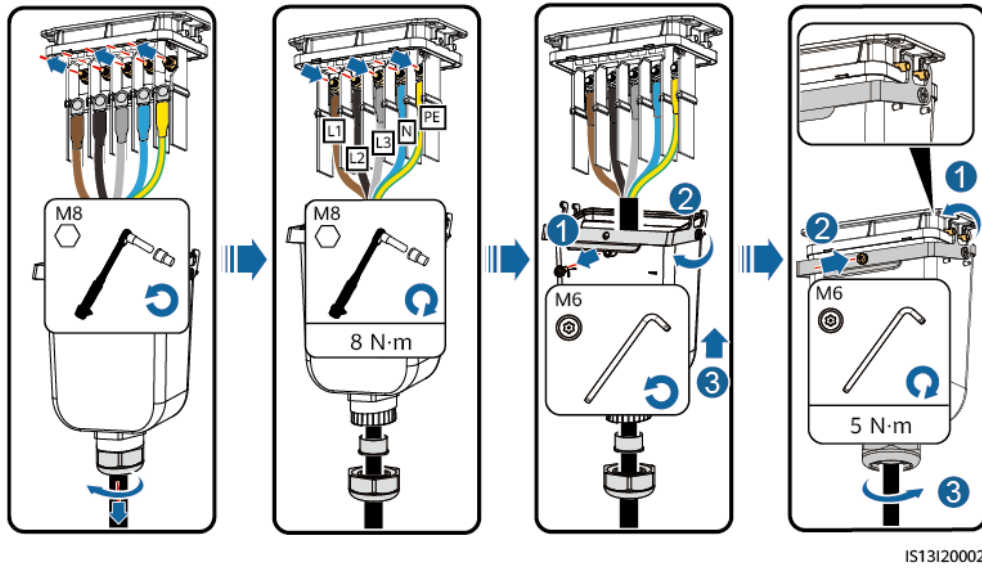
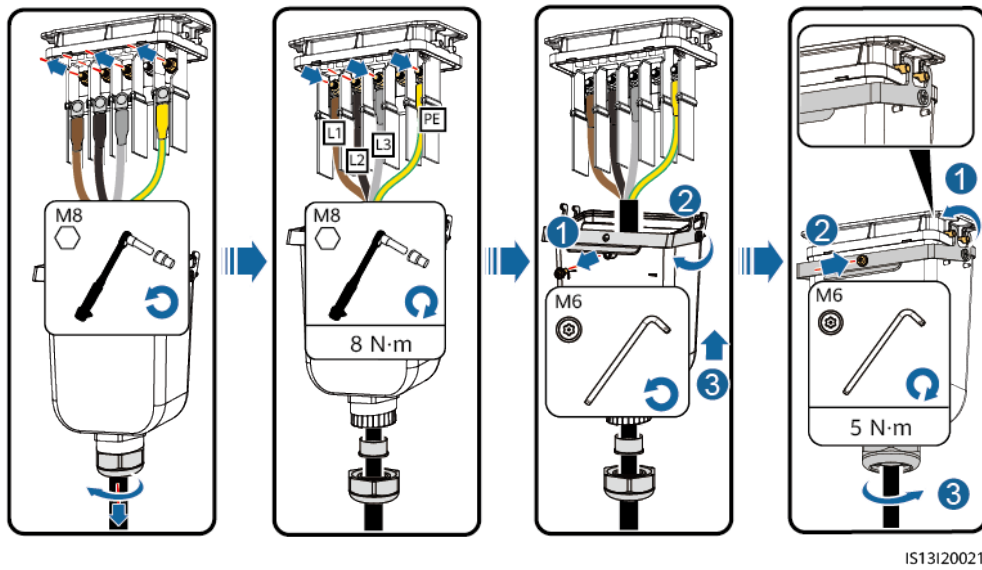

Figure 5-7 Five-core cable (L1, L2, L3, N, and PE)



IS13I20002

Figure 5-8 Four-core cable (L1, L2, L3, and PE)



IS13I20021

Figure 5-9 Four-core cable (L1, L2, L3, and N)

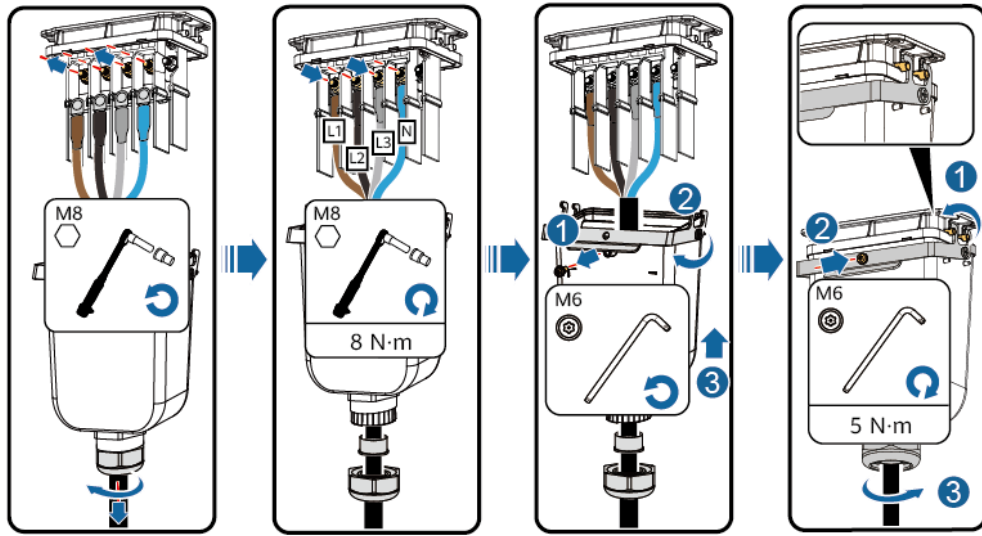

IS13I20005

Figure 5-10 Three-core cable (L1, L2, and L3)

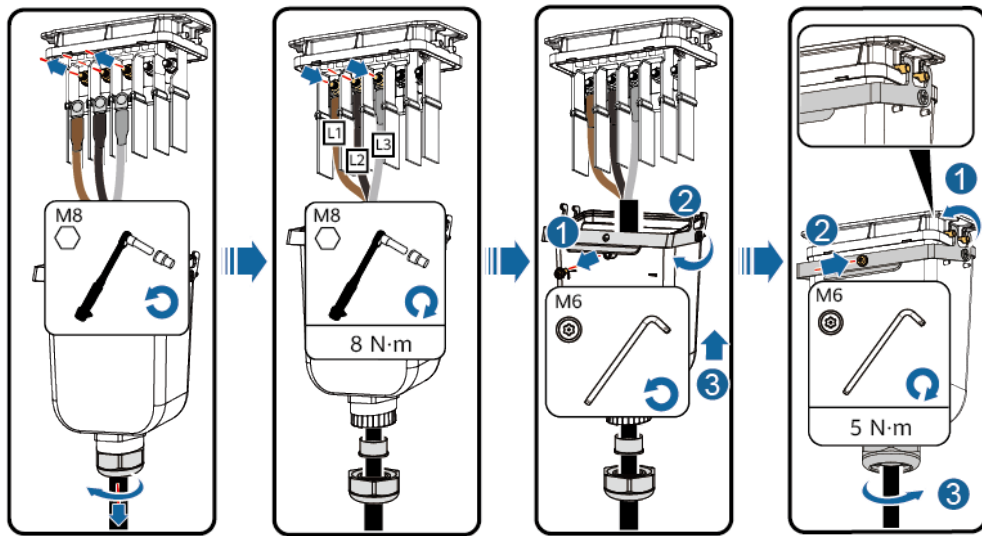

IS13I20020

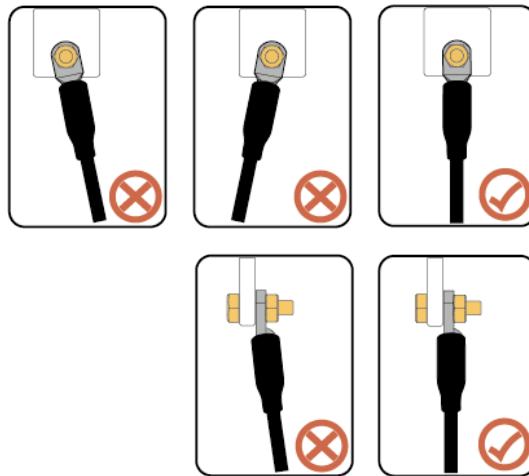
Figure 5-11 Wiring requirements

---End

5.5 Installing the DC Input Power Cable

5.5.1 Cable Connection Description

Precautions

⚠ DANGER

- Before connecting the DC input power cables, ensure that the DC voltage is within the safe range (lower than 60 V DC) and that the DC switch on the ISTORE is OFF. Failing to do so may result in electric shocks.
 - When the ISTORE is running, it is not allowed to work on the DC input power cables, such as connecting or disconnecting a PV string or a PV module in a PV string. Failing to do so may cause electric shocks.
 - If no PV string connects to a DC input terminal of the ISTORE, do not remove the watertight cap from the DC input terminals. Otherwise, the IP rating of the ISTORE will be affected.
-

⚠ WARNING

Ensure that the following conditions are met. Otherwise, the ISTORE may be damaged, or even a fire could happen.

- PV modules connected in series in each PV string are of the same specifications.
- The DC input voltage of the IS-INV-29900/40000-3PH shall not exceed 1100 V DC under any circumstance.
- The polarities of electric connections are correct on the DC input side. The positive and negative terminals of a PV string connect to corresponding positive and negative DC input terminals of the ISTORE.
- If polarity of the DC input power cable is reversed and the DC switch is ON, do not turn off the DC switch immediately or remove positive and negative connectors. Wait until the solar irradiance declines at night and the PV string current reduces to below 0.5 A, and then turn off the DC switch and remove the positive and negative connectors. Correct the PV string polarity before reconnecting the PV string to the ISTORE.

NOTICE

- The ISTORE does not support power supplies other than PV strings. Since the output of the PV string connected to the ISTORE cannot be grounded, ensure that the PV module output is well insulated to ground.
- During the installation of PV strings and the ISTORE, the positive or negative terminals of PV strings may be short-circuited to ground if the power cable is not properly installed or routed. In this case, an AC or DC short circuit may occur and damage the ISTORE. The caused device damage is not covered under any warranty.

Figure 5-12 DC input terminals

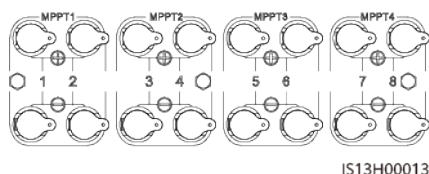

When the DC input is not fully configured, the DC input terminals must meet the following requirements:

1. Distribute the DC input power cables evenly over four MPPT circuits, and connect them preferentially through MPPT1 and MPPT4.
2. Maximize the number of connected MPPT circuits.

Number of PV Strings	Terminal Selection	Number of PV Strings	Terminal Selection
1	PV1	2	PV1 and PV7
3	PV1, PV3 and PV7	4	PV1, PV3, PV5 and PV7
5	PV1, PV2, PV3, PV5 and PV7	6	PV1, PV2, PV3, PV5, PV7 and PV8
7	PV1, PV2, PV3, PV4, PV5, PV7 and PV8	8	PV1, PV2, PV3, PV4, PV5, PV6, PV7 and PV8

5.5.2 Connecting Cables to Amphenol Helios H4 Connectors

CAUTION

Use the positive and negative Amphenol Helios H4 metal terminals and DC connectors supplied with the solar inverter. Using incompatible positive and negative metal terminals and DC connectors may result in serious consequences. The caused device damage is not covered under any warranty.

NOTICE

- You are advised to use the H4TC0003 (Amphenol) crimping tool and do not use it with the positioning block. Otherwise, the metal terminals may be damaged.
 - The H4TW0001 (Amphenol) open-end wrench is recommended.
 - Cables with high rigidity, such as armored cables, are not recommended as DC input power cables, because poor contact may be caused by the bending of the cables.
 - Before assembling DC connectors, label the cable polarities correctly to ensure correct cable connections.
 - After the positive and negative connectors snap into place, pull the DC input cables back to ensure that they are connected securely.
 - If the PV string is configured with a 3rd party optimizer, check the cable polarity by referring to documentation provided by the PV optimizer supplier.
-

Procedure

- Step 1** Connect the DC power cable.

Figure 5-13 Connecting the DC power cable

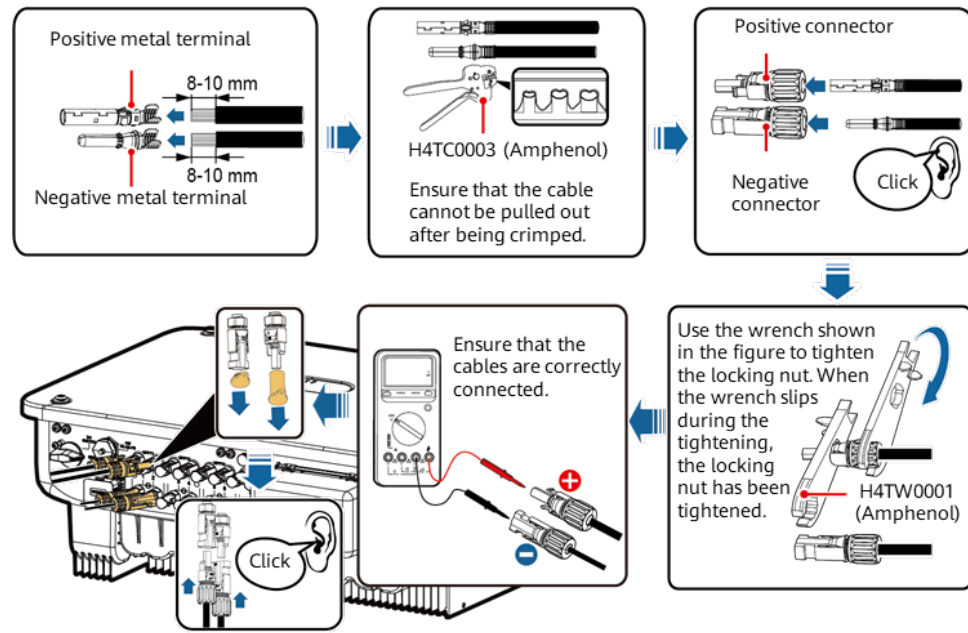

----End

NOTICE

During DC input power cabling, leave at least 50 mm of slack. The axial tension on PV connectors must not exceed 80 N. Radial stress or torque must not be generated on PV connectors.

5.5.3 Connecting Cables to Staubli MC4 Connectors

CAUTION

Use the positive and negative Staubli MC4 metal terminals and DC connectors supplied with the ISTORE. Using incompatible positive and negative metal terminals and DC connectors may result in serious consequences. The caused device damage is not covered under warranty.

NOTICE

- You are advised to use the PV-CZM-22100 (Staubli) crimping tool and do not use it with the positioning block. Otherwise, the metal terminals may be damaged.
- The PV-MS (Staubli) or PV-MS-HZ (Staubli) open-end wrench is recommended.
- Cables with high rigidity, such as armored cables, are not recommended as DC input power cables, because poor contact may be caused by the bending of the cables.
- Before assembling DC connectors, label the cable polarities correctly to ensure correct cable connections.
- After the positive and negative connectors snap into place, pull the DC input cables back to ensure that they are connected securely.
- If the PV string is configured with a 3rd party optimizer, check the cable polarity by referring to documentation provided by the PV optimizer supplier.

Step 1 Connect the DC power cable.

Figure 5-14 Connecting the DC power cable

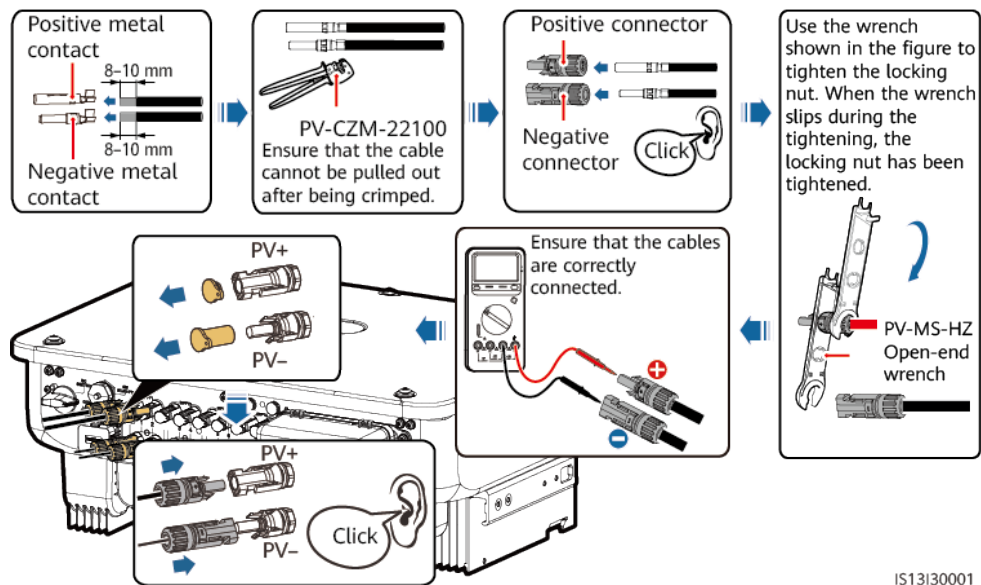

IS13130001

----End

NOTICE

During DC input power cabling, leave at least 50 mm of slack. The axial tension on PV connectors must not exceed 80 N. Radial stress or torque must not be generated on PV connectors.

5.6 (Optional) Installing the Smart Dongle

Procedure

NOTE

The Smart Dongle is not provided in standard configuration.

- WLAN-FE Smart Dongle (WLAN Communication)

Figure 5-15 Installing a WLAN-FE Smart Dongle (WLAN communication)

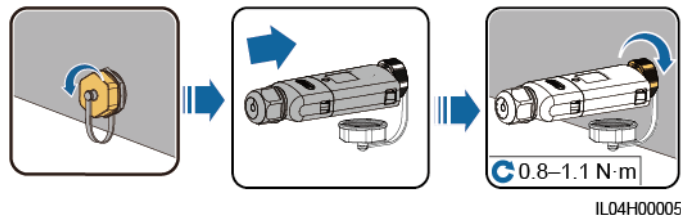

- WLAN-FE Smart Dongle (FE Communication)

Figure 5-16 Installing a WLAN-FE Smart Dongle (FE communication)

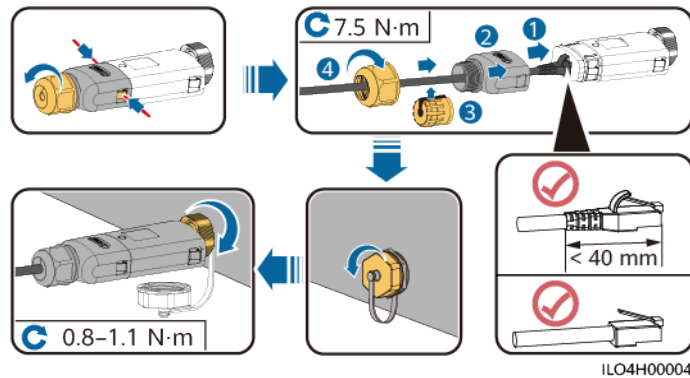

NOTICE

Install the network cable before installing the Smart Dongle on the solar inverter.

NOTE

- For details about how to operate the WLAN-FE Smart Dongle IS-DONGLE-WLAN, see Smart WLAN-FE Dongle Quick Guide (IS-DONGLE-WLAN).

5.7 Connecting the Signal Cable

COM Port Pin Definitions

NOTICE

When laying out a signal cable, separate it from power cables to avoid strong signal interference.

Figure 5-17 Pin definitions

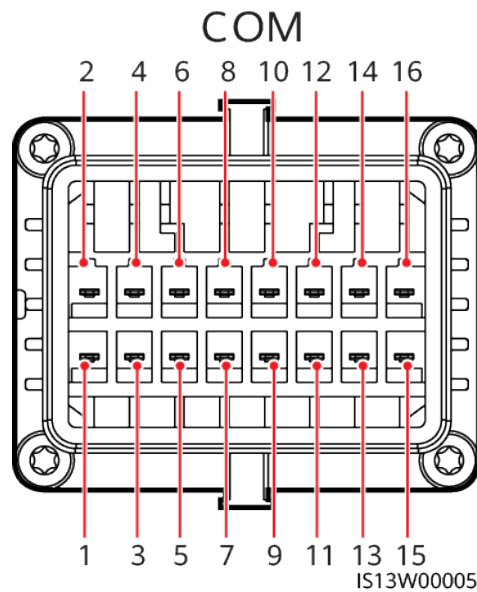

Pin	Definition	Function	Description	Pin	Definition	Function	Description
1	485A1_1	RS485 differential signal +	Used to cascade inverters or connect to the IS-LOGGER.	2	485A1_2	RS485 differential signal +	Used to cascade inverters or connect to the IS-LOGGER.
3	485B1_1	RS485 differential signal -		4	485B1_2	RS485 differential signal -	
5	PE	Ground point on the shield layer	-	6	PE	Ground point on the shield layer	-
7	485A2	RS485 differential signal +	Connects to the RS485 signal port for controlling the power meter at	8	DIN1	Dry contact for power grid scheduling	-
9	485B2	RS485 differential		10	DIN2		

Pin	Definiton	Function	Description	Pin	Definiton	Function	Description
		signal –	the grid-tied point.				
11	-	-	-	12	DIN3		
13	GND	GND	-	14	DIN4		
15	DIN5	Rapid shutdown	Used to connect to the rapid shutdown DI signal port	16	GND		

Scenarios Where No Signal Cable Is Connected

NOTICE

If no signal cable is required for the ISTORE, use waterproof plugs to block the wiring holes on the signal cable connector and connect the signal cable connector to the communications port on the ISTORE to improve the waterproof performance of the ISTORE.

Figure 5-18 Securing the signal cable connector

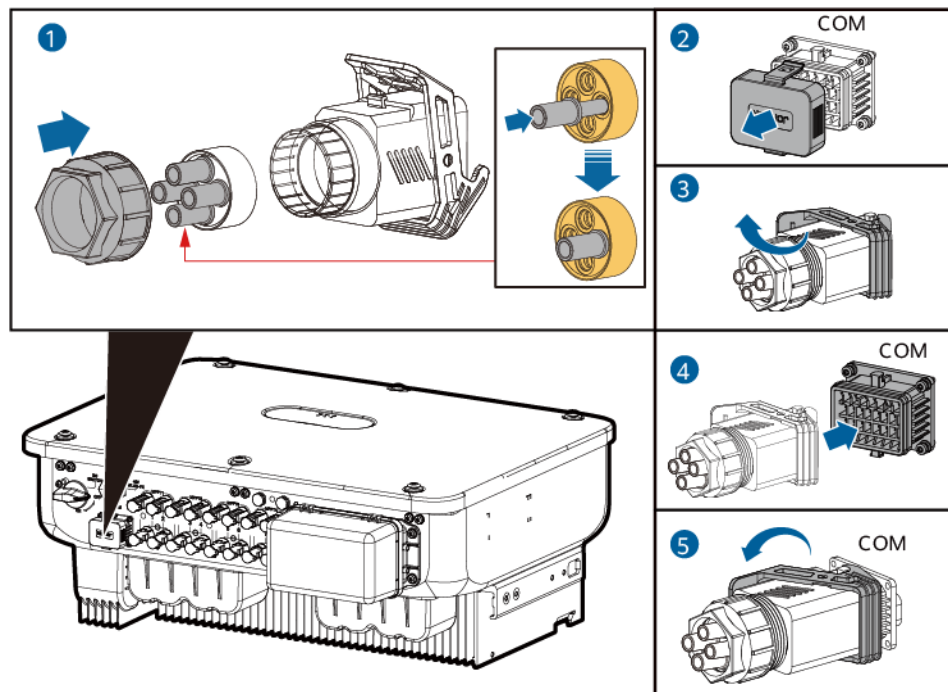

IS13140003

5.7.1 Communication Modes

RS485 Communication

- Smart Dongle networking (IS-DONGLE-WLAN)

Figure 5-19 Smart Dongle networking

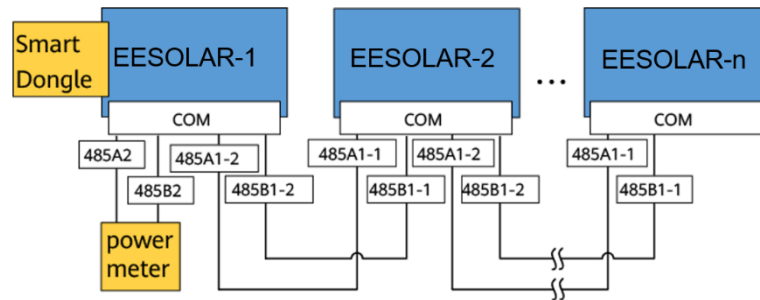

NOTE

If an ISTORE is networked using a Smart Dongle, it cannot be connected to the IS-LOGGER3000.

- SmartLogger networking (IS-LOGGER3000)

Figure 5-20 SmartLogger networking

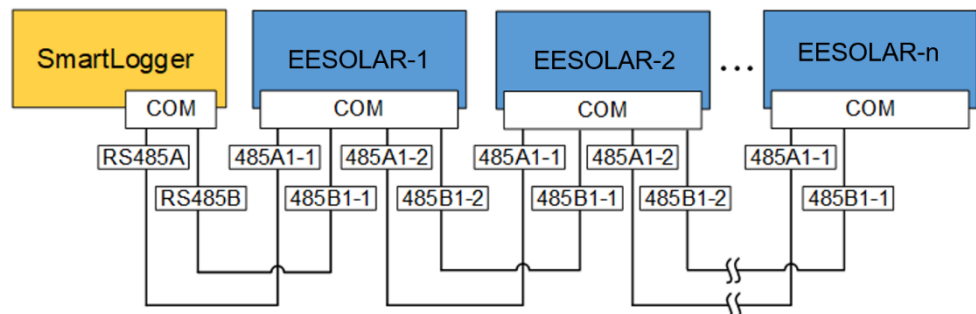

NOTE

- If an ISTORE is networked using the IS-LOGGER3000, it cannot be connected to a Smart Dongle.
- It is recommended that the number of ISTOREs connected to each RS485 route be less than 30.

5.7.2 (Optional) Connecting the RS485 Communications Cable to the ISTORE

Procedure

- Step 1** Connect the signal cable to the signal cable connector.

Figure 5-21 Connecting the cable

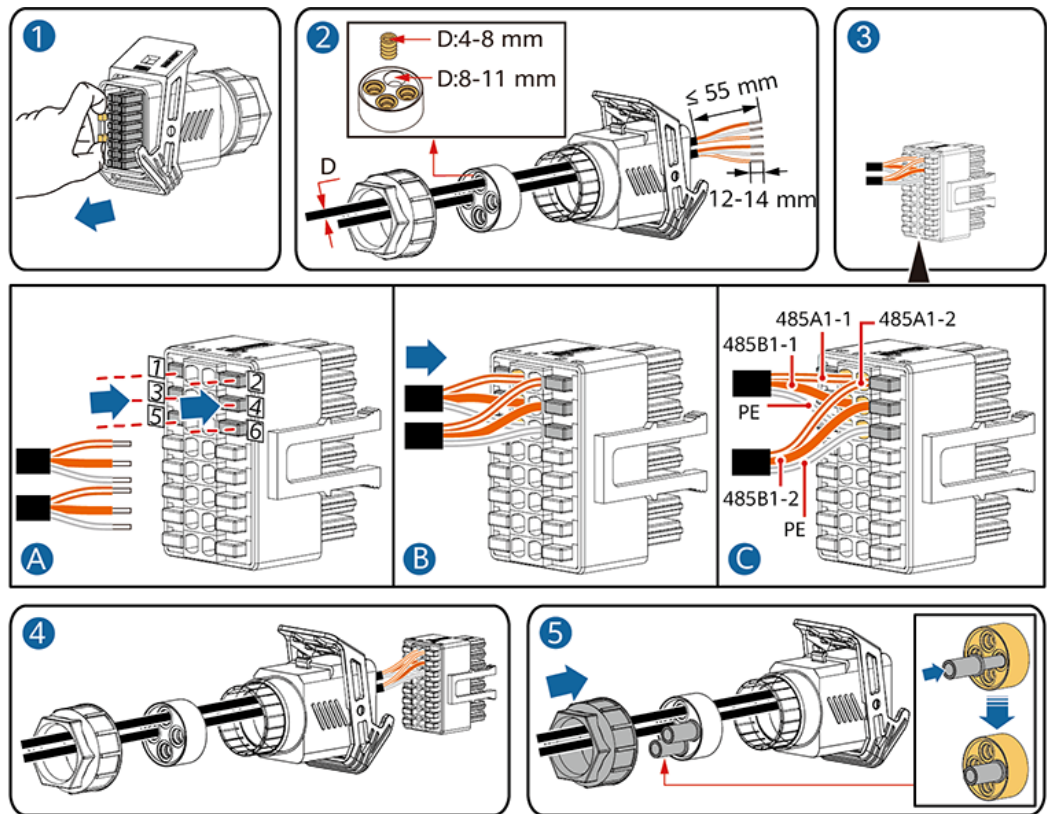

IS10120006

Step 2 Connect the signal cable connector to the COM port.

Figure 5-22 Securing the signal cable connector

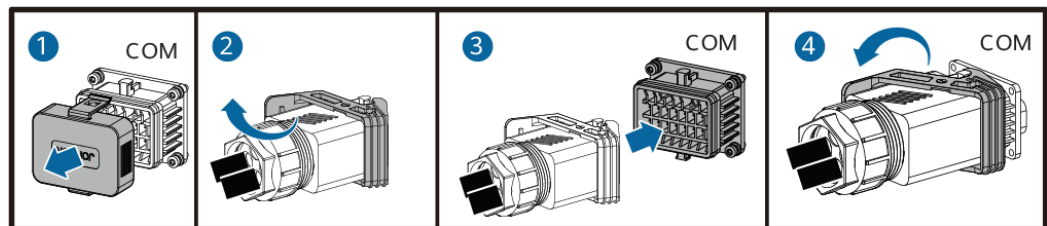

IS13140001

----End

5.7.3 (Optional) Connecting the RS485 Communications Cable to the Power Meter

Procedure

Step 1 Connect the signal cable to the signal cable connector.

Figure 5-23 Connecting the cable

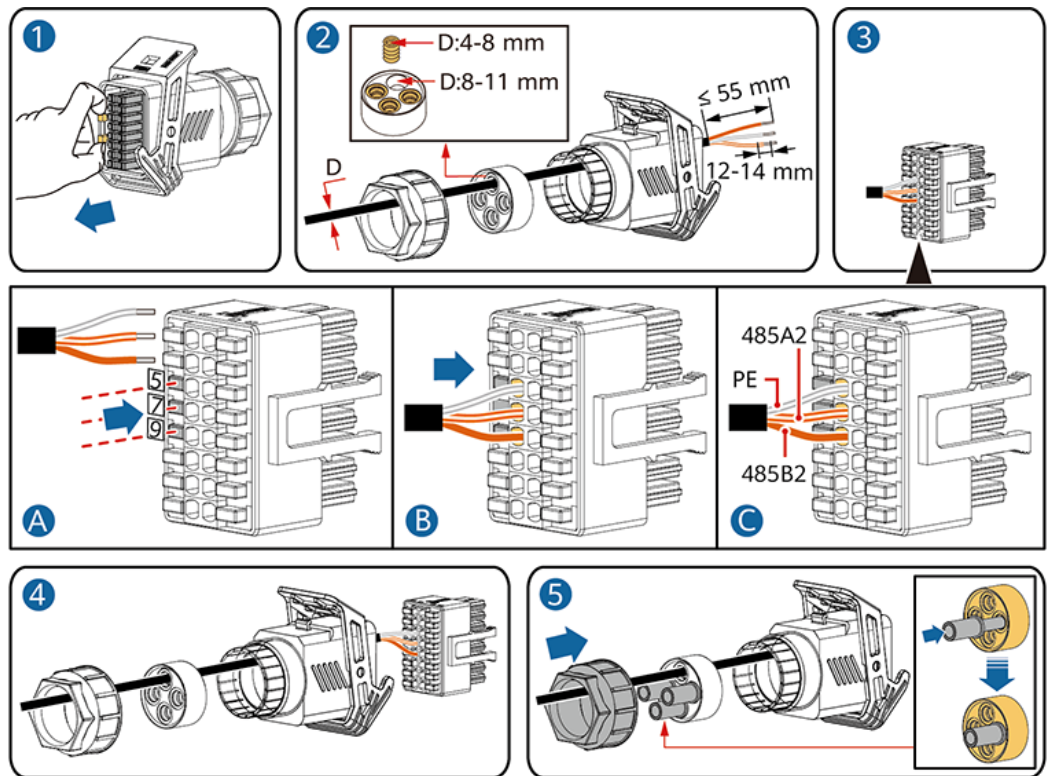

IS10I20008

Step 2 Connect the signal cable connector to the COM port.

Figure 5-24 Securing the signal cable connector

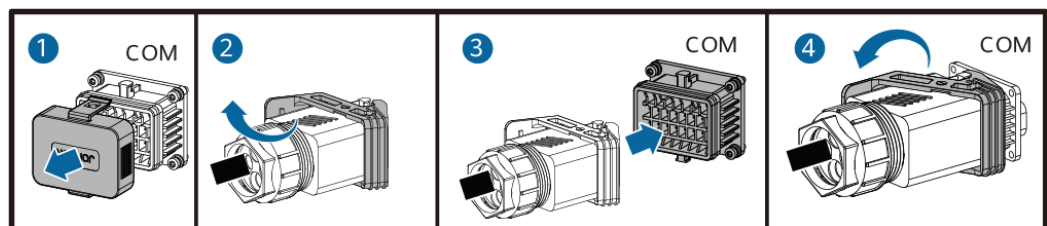

IS13I40001

---End

5.7.4 (Optional) Connecting the Power Grid Scheduling Signal Cable

Procedure

Step 1 Connect the signal cable to the signal cable connector.

Figure 5-25 Connecting the cable

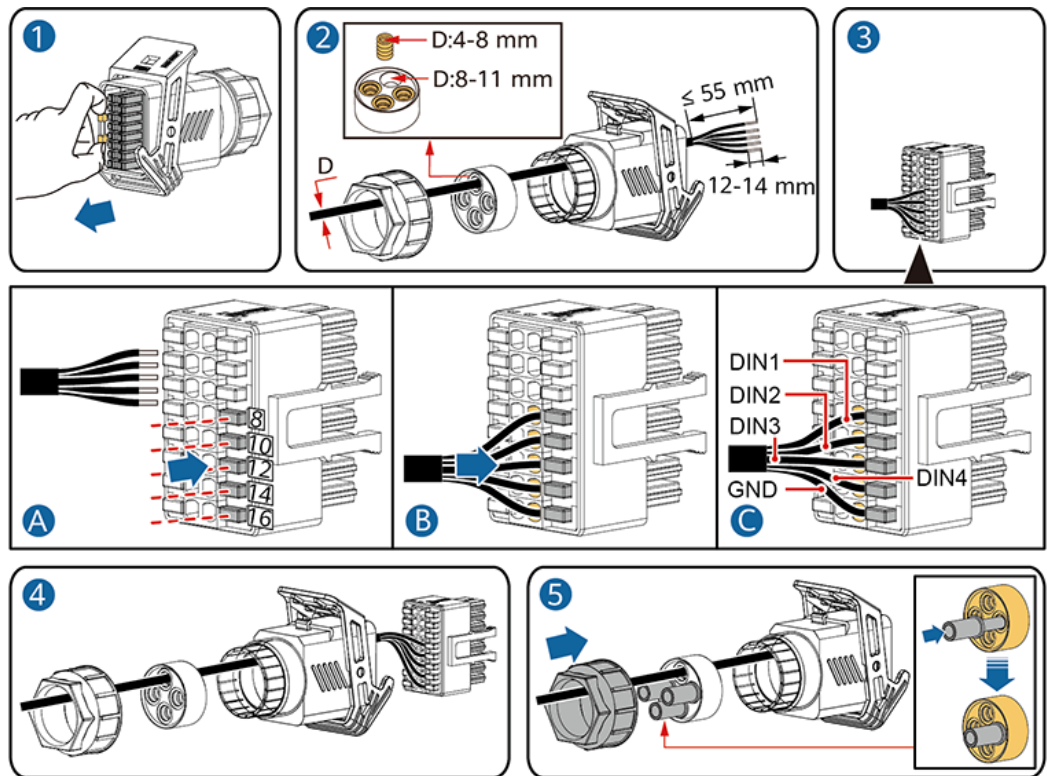

IS10I20010

Step 2 Connect the signal cable connector to the COM port.

Figure 5-26 Securing the signal cable connector

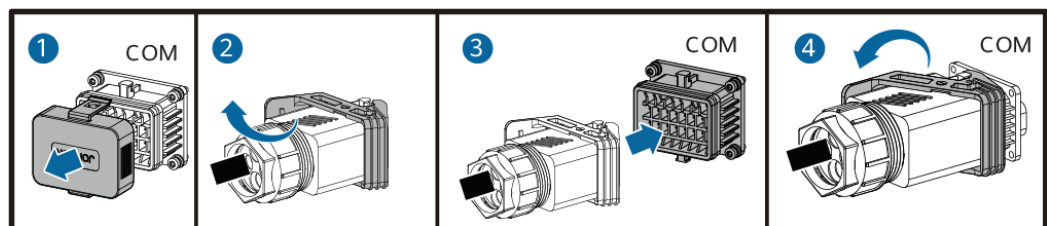

IS13I40001

---End

5.7.5 (Optional) Connecting the Rapid Shutdown Signal Cable

Procedure

Step 1 Connect the signal cable to the signal cable connector.

Figure 5-27 Connecting the cable

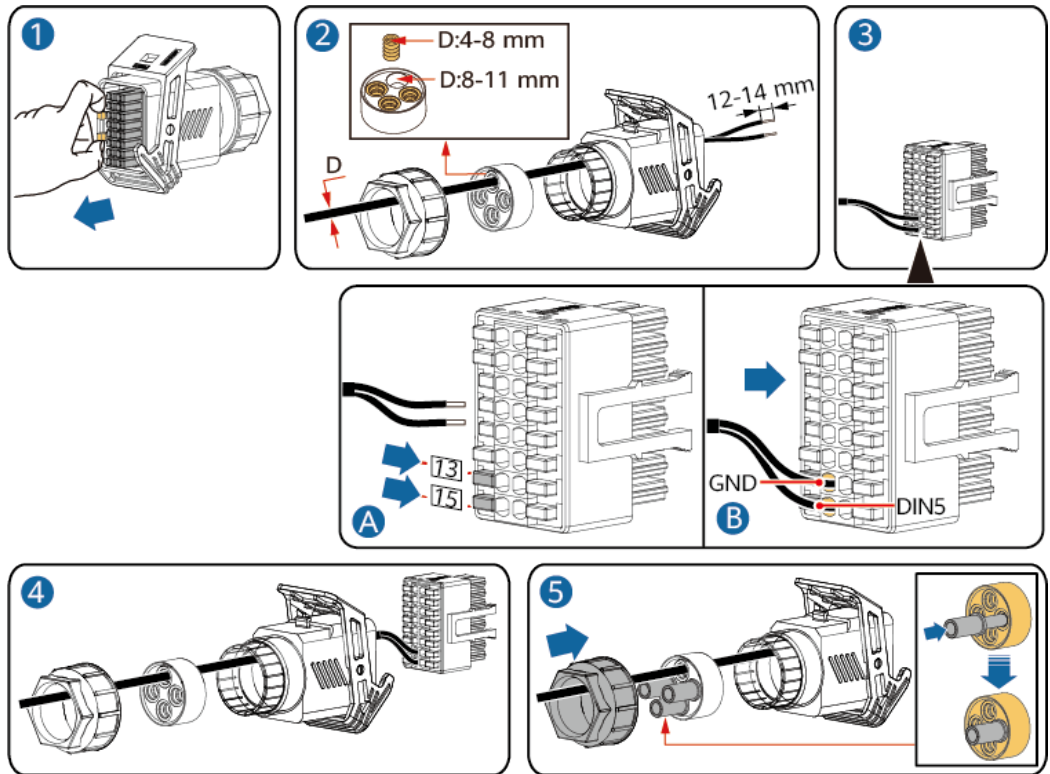

IS13140004

Step 2 Connect the signal cable connector to the COM port.

Figure 5-28 Securing the signal cable connector

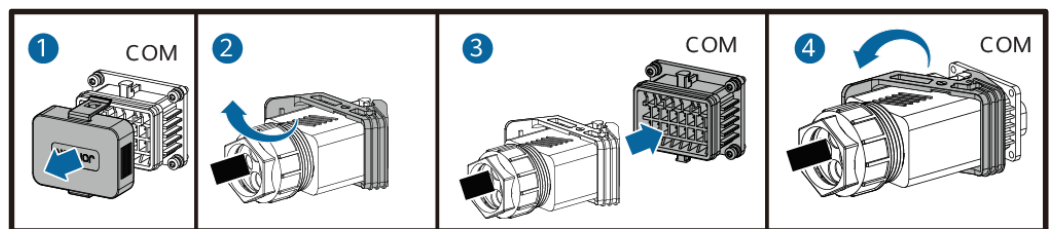

IS13140001

----End

6 Commissioning

DANGER

- Wear personal protective equipment and use dedicated insulated tools to avoid electric shocks or short circuits.

6.1 Checking Before Power-On

Table 6-1 Checklist

No.	Check Item	Acceptance Criteria
1	ISTORE installation	The ISTORE is installed correctly and securely.
2	Smart Dongle	The Smart Dongle is installed correctly and securely.
3	Cable routing	The cables are routed properly as required by the customer.
4	Cable ties	Cable ties are evenly distributed and no burr exists.
5	Reliable grounding	The PE cable is connected correctly and securely.
6	Switch	DC switches and all the switches connecting to the ISTORE are OFF.
7	Cable connection	The AC output power cable, and DC input power cables are connected correctly and securely.
8	Unused terminals and ports	Unused terminals and ports are locked by watertight caps.
9	Installation environment	The installation space is proper, and the

No.	Check Item	Acceptance Criteria
		installation environment is clean and tidy.

6.2 System Power-On

Prerequisites

DANGER

- Wear personal protective equipment and use dedicated insulated tools to avoid electric shocks or short circuits.

NOTICE

- Before turning on the AC switch between the ISTORE and the power grid, check that the AC voltage is within the specified range using a multimeter.
- If the DC power supply is connected but the AC power supply is disconnected, the ISTORE will report a **Grid Loss** alarm. The ISTORE can start properly only after the power grid recovers.
- If the DC switch locking screw is missing, the customer shall purchase an M4x20 hex socket stainless steel screw to lock the switch in the OFF state.

Procedure

- Step 1** Turn on the AC switch between the ISTORE and the power grid.
- Step 2** (Optional) Remove the locking screw beside the DC switch. Place the removed screw into a temporary placement hole for future power-off and maintenance.

Figure 6-1 Removing the locking screw beside the DC switch

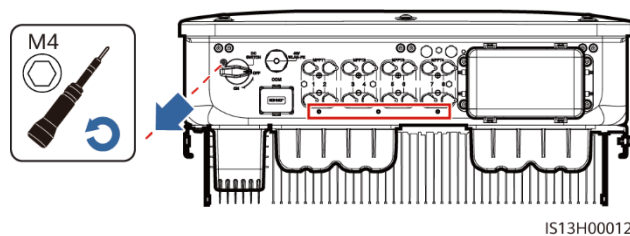

IS13H00012

- Step 3** Turn on the DC switch at the bottom of the ISTORE.
- Step 4** Observe the LED indicators to check the operating status of the ISTORE.

Table 6-2 Indicator description

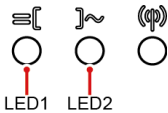
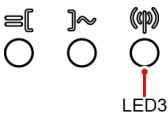
Category	Status		Description
Running indicator 	LED1	LED2	–
	Steady green	Steady green	The ISTORE is operating in grid-tied mode.
	Blinking green slowly (on for 1s and off for 1s)	Off	The DC is on and the AC is off.
	Blinking green slowly (on for 1s and off for 1s)	Blinking green slowly (on for 1s and off for 1s)	Both the DC and AC are on, and the ISTORE is not supplying power to the power grid.
	Off	Blinking green slowly	The DC is off and the AC is on.
	Off	Off	Both the DC and AC are off.
	Blinking red fast (on for 0.2s and off for 0.2s)	–	DC environment alarm
	–	Blinking red fast (on for 0.2s and off for 0.2s)	AC environment alarm
	Steady red	Steady red	Faulty
Communications indicator 	LED3		–
	Blinking green fast (on for 0.2s and then off for 0.2s)		Communication is in progress.
	Blinking green slowly (on for 1s and off for 1s)		A mobile phone is connected.
Off		No communication	
Note: If LED1, LED2, and LED3 are steady red, the ISTORE is faulty and needs to be replaced.			

Step 8 Installer needs to follow the Section 7 with the proper commissioning before inverter starts to operate. The correct grid code must be selected by referencing Appendix A Grid Code.

----End

7 Man-Machine Interaction

7.1 App Commissioning

You can use the app to perform local maintenance operations, such as device commissioning, parameter setting, log export, and software upgrade.

7.1.1 Downloading the HiSolar App

Search for **HiSolar** on Google Play and download the latest installation package.

7.1.2 Connecting to the Inverter

Step 1 You can connect to the inverter by scanning the QR code or choosing manual connection on the app.

- Scanning the QR code: Tap **Connect** and scan the QR code of the inverter to automatically connect to the inverter.
- Manual connection: Tap **Manual connection**, select **WLAN connection**, and connect to the corresponding WLAN hotspot in the WLAN list on the app. The initial name of the WLAN hotspot is the inverter SN, and the initial password is **Changeme**.

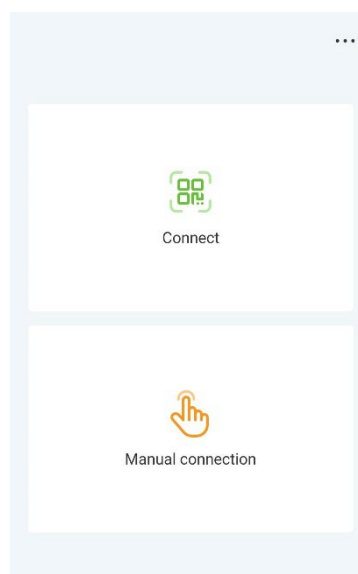

Step 2 Log in as an **Installer**. Set the login password upon the first login.

NOTICE

To ensure account security, protect the password by changing it periodically, and keep it secure.

7.1.3 Quick Settings

Set parameters as prompted on the **Quick settings** screen.

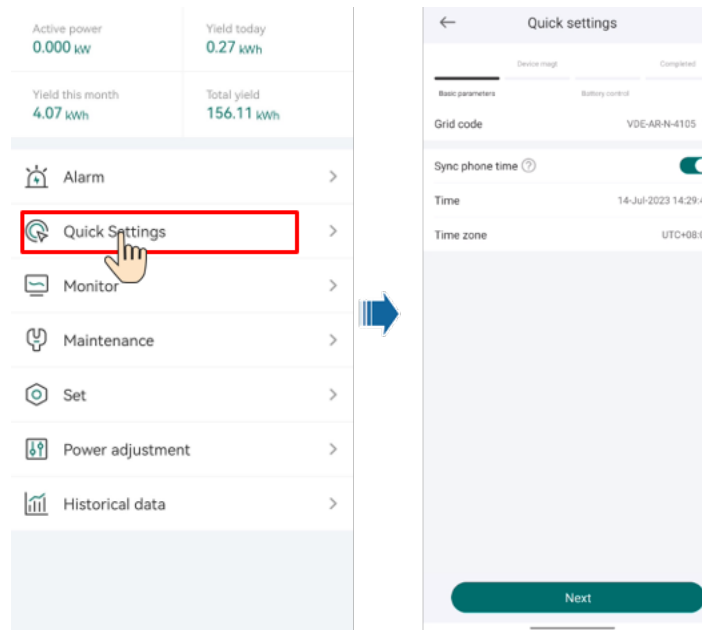

NOTE

The user interface (UI) varies with associated devices. The preceding UI screenshots are for reference only.

7.1.4 What Should I Do If the Device Is Disconnected from the App When I Switch the Local Commissioning Screen to the Background?

During local commissioning, you may need to switch the app to the background (for example, uploading an upgrade package, uploading a photo, or scanning a QR code for WLAN connection). When you switch back to the app screen, a message is displayed, indicating that the device is disconnected from the app and you need to log in again.

Solution

Step 1 Disable **WLAN+** if available on your mobile phone.

Step 2 Tap **Settings > Apps & services**, and choose **Launch manager**.

Step 3 Tap **Manage manually > Run in background** for the HiSolar app.

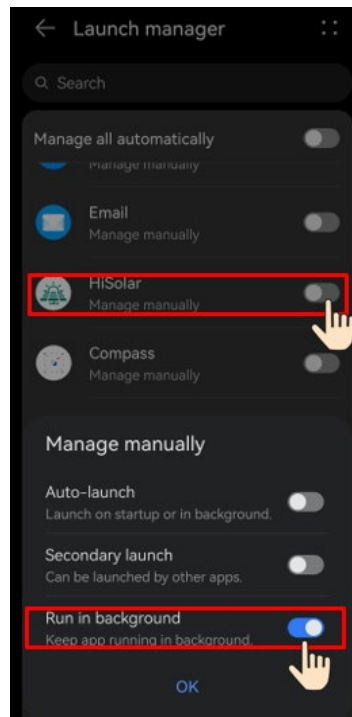

NOTE

The menu name may vary according to the mobile phone brand.

7.2 Parameters Settings

Set inverter parameters. For details about entering the device commissioning screen, see [B Device Commissioning](#).

7.2.1 Energy Control

7.2.1.1 Grid-tied Point Control

Function

Limits or reduces the output power of the PV power system to ensure that the output power is within the power deviation limit.

Procedure

Step 1 On the home screen, choose **Power adjustment > Grid-tied point control**.

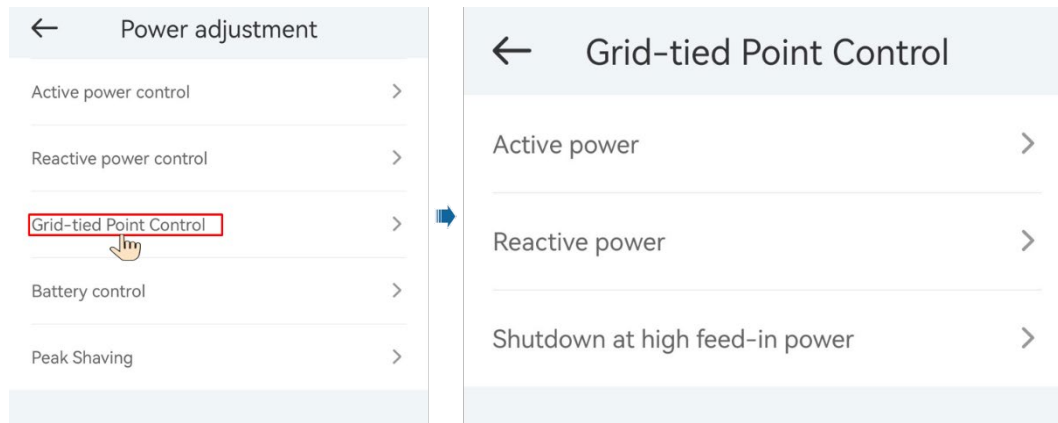

Table 7-1 Grid-tied point control

Parameter Name			Description
Active power	Unlimited	-	If this parameter is set to Unlimited , the output power of the inverter is not limited and the inverter can connect to the power grid at the rated power.
	Grid connected with zero power	Closed-loop controller	<ul style="list-style-type: none"> If multiple inverters are cascaded, set this parameter to IS-DONGLE-WLAN. If there is only one inverter, set this parameter to Inverter.
		Limitation mode	Total power indicates export limitation of the total power at the grid-tied point.
		Power adjustment interval	Specifies the shortest interval for a single anti-backfeeding adjustment.
		Power raising threshold	Specifies the dead zone for adjusting the inverter output power. If the power fluctuation is within the power control hysteresis, the power is not adjusted.
		Communication disconnection fail-safe	In the inverter anti-backfeeding scenario, if this parameter is set to Enable , the inverter will derate according to the active power derating percentage when the communication between the inverter and the Smart Dongle is disconnected for a period longer than Communication disconnection detection time .
		Communication disconnection detection time	Specifies the time for determining the communication disconnection between the inverter and the Dongle. This parameter is displayed when Communication disconnection fail-safe is set to Enable .
		Active power threshold	Specifies the derating value of the

Parameter Name		Description
		when communication fails inverter active power by percentage. If the Smart Dongle does not detect any meter data or the communication between the Smart Dongle and the inverter is disconnected, the Smart Dongle delivers the derating value of the inverter active power by percentage.
Limited feed-in (kW)	Closed-loop controller	<ul style="list-style-type: none"> If multiple inverters are cascaded, set this parameter to IS-DONGLE-WLAN. If there is only one inverter, set this parameter to Inverter.
	Limitation mode	Total power indicates export limitation of the total power at the grid-tied point.
	Maximum grid feed-in power	Specifies the maximum active power transmitted from the grid-tied point to the power grid.
	Power adjustment interval	Specifies the shortest interval for a single anti-backfeeding adjustment.
	Power raising threshold	Specifies the dead zone for adjusting the inverter output power. If the power fluctuation is within the power control hysteresis, the power is not adjusted.
	Communication disconnection fail-safe	In the inverter anti-backfeeding scenario, if this parameter is set to Enable , the inverter will derate according to the active power derating percentage when the communication between the inverter and the Smart Dongle is disconnected for a period longer than Communication disconnection detection time .
	Communication disconnection detection time	Specifies the time for determining the communication disconnection between the inverter and the Dongle. This parameter is displayed when Communication disconnection fail-safe is set to Enable .
	Active power threshold when communication fails	Specifies the derating value of the inverter active power by percentage. If the Smart Dongle does not detect any meter data or the communication between the Smart Dongle and the inverter is disconnected, the Smart Dongle delivers the derating value of the inverter active power by percentage.
Power-limited grid	Closed-loop controller	<ul style="list-style-type: none"> If multiple inverters are cascaded, set

Parameter Name		Description
	connected (%)	<p>this parameter to IS-DONGLE-WLAN.</p> <ul style="list-style-type: none"> If there is only one inverter, set this parameter to Inverter.
	Limitation mode	Total power indicates export limitation of the total power at the grid-tied point.
	PV plant capacity	Specifies the total maximum active power in the inverter cascading scenario.
	Maximum grid feed-in power	Specifies the percentage of the maximum active power of the grid-tied point to the PV plant capacity.
	Power adjustment interval	Specifies the shortest interval for a single anti-backfeeding adjustment.
	Power raising threshold	Specifies the dead zone for adjusting the inverter output power. If the power fluctuation is within the power control hysteresis, the power is not adjusted.
	Communication disconnection fail-safe	In the inverter anti-backfeeding scenario, if this parameter is set to Enable , the inverter will derate according to the active power derating percentage when the communication between the inverter and the Smart Dongle is disconnected for a period longer than Communication disconnection detection time .
	Communication disconnection detection time	<p>Specifies the time for determining the communication disconnection between the inverter and the Dongle.</p> <p>This parameter is displayed when Communication disconnection fail-safe is set to Enable.</p>
Active power threshold when communication fails	Specifies the derating value of the inverter active power by percentage. If the Smart Dongle does not detect any meter data or the communication between the Smart Dongle and the inverter is disconnected, the Smart Dongle delivers the derating value of the inverter active power by percentage.	
Shutdown at high feed-in power	<p>Shutdown at high feed-in power</p> <ul style="list-style-type: none"> The default value is Disable. If this parameter is set to Enable, the inverter shuts down for protection when the grid-connection point power exceeds the threshold and remains in this condition for the specified time 	

Parameter Name	Description
	threshold.
Upper feed-in power threshold for inverter shutdown (kW)	<ul style="list-style-type: none"> The default value is 0. This parameter specifies the power threshold of the grid-connection point for triggering inverter shutdown.
High feed-in power duration threshold for triggering inverter shutdown (s)	<p>The default value is 20. This parameter specifies the duration threshold of high feed-in power for triggering inverter shutdown.</p> <ul style="list-style-type: none"> When High feed-in power duration threshold for triggering inverter shutdown is set to 5, Shutdown at high feed-in power takes precedence. When High feed-in power duration threshold for triggering inverter shutdown is set to 20, Grid connection with limited power takes precedence (when Active power control is set to Grid connection with limited power).

----End

7.2.1.2 Apparent Power Control on the Inverter Output Side

On the home screen, tap **Set > Power adjustment** to set inverter parameters.

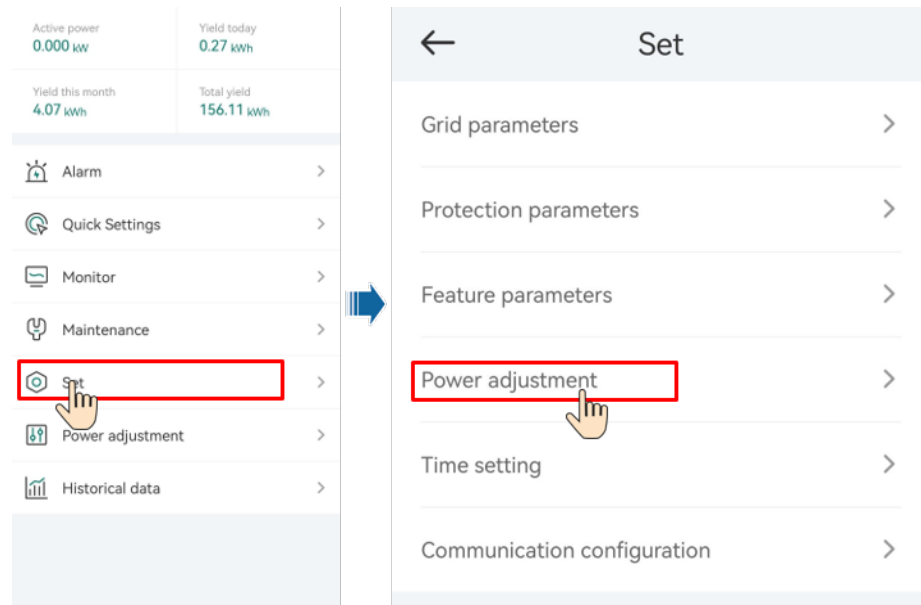

Parameter	Description	Value Range
Maximum apparent power (kVA)	Specifies the output upper threshold for the maximum apparent power to adapt to the capacity requirements of standard and customized inverters.	[Maximum active power, S_{\max}]
Maximum active power (kW)	Specifies the output upper threshold for the maximum active power to adapt to different market requirements.	[0.1, P_{\max}]

 **NOTE**

The lower threshold for the maximum apparent power is the maximum active power. To lower the maximum apparent power, lower the maximum active power first.

7.2.2 AFCI

Function

If PV modules or cables are not properly connected or damaged, electric arcs may occur, which may cause fire. Inverters provide unique arc detection in compliance with UL 1699B-2018 to ensure the safety of users' lives and property.

This function is enabled by default. The inverter automatically detects arc faults. To disable this function, log in to the HiSolar App, on the home screen, choose **Set > Feature parameters**, and disable **AFCI**.

 **NOTE**

The AFCI function works only with ordinary PV modules, but does not support intelligent PV modules.

Clearing Alarms

The AFCI function involves the **DC arc fault** alarm.

The inverter has the AFCI alarm automatic clearance mechanism. If an alarm is triggered for less than five times within 24 hours, the inverter automatically clears the alarm. If the alarm is triggered for five times or more within 24 hours, the inverter locks for protection. You need to manually clear the alarm on the inverter so that it can work properly.

You can manually clear the alarm as follows:

Log in to the HiSolar App and on the home screen, connect and log in to the inverter that generates the AFCI alarm, tap **Alarm**, and tap **Clear** on the right of the **DC arc fault** alarm to clear the alarm.

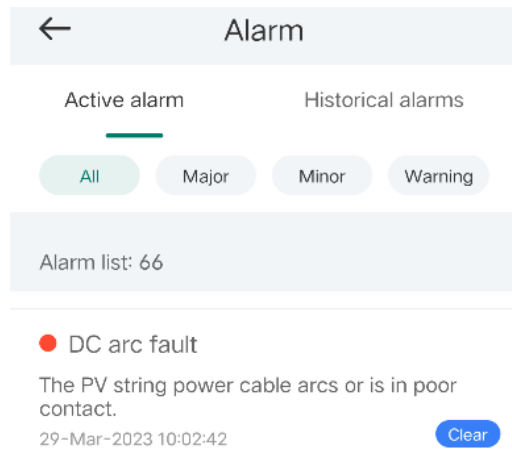

7.2.3 DRM

Function

According to AS/NZS 4777.2:2020+A1:2021, solar inverters need to support the function of demand response mode (DRM), and DRM0 is a mandatory requirement.

The inverter must be connected with external device IS-LOGGER3000. The demand response enabling device directly connected to IS-LOGGER3000 and inverter connected to IS-LOGGER3000 via communication RS485.

This function is disabled by default.

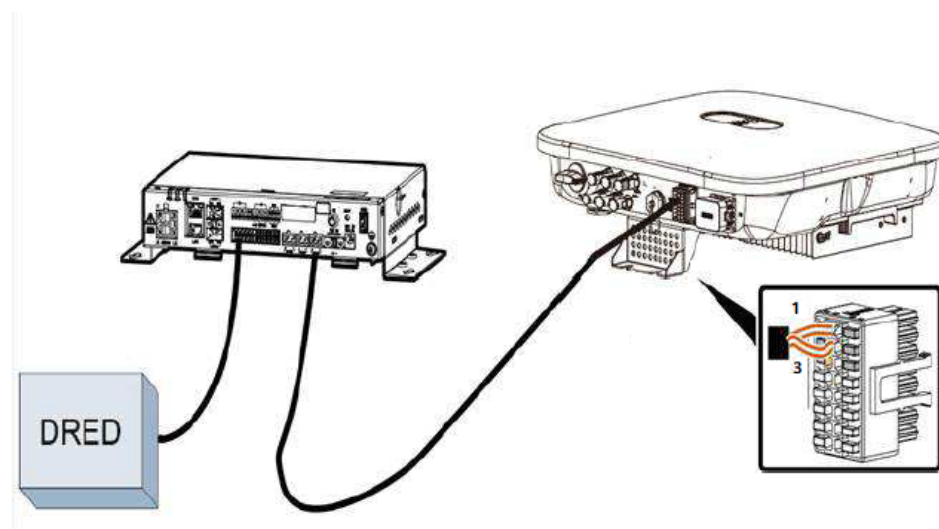

NOTE

The demand response enabling device (DRED) is a power grid dispatch device.

Procedure

Step 1 On the home page, choose **Set > Feature parameters**.

Step 2 Set **DRM** to .

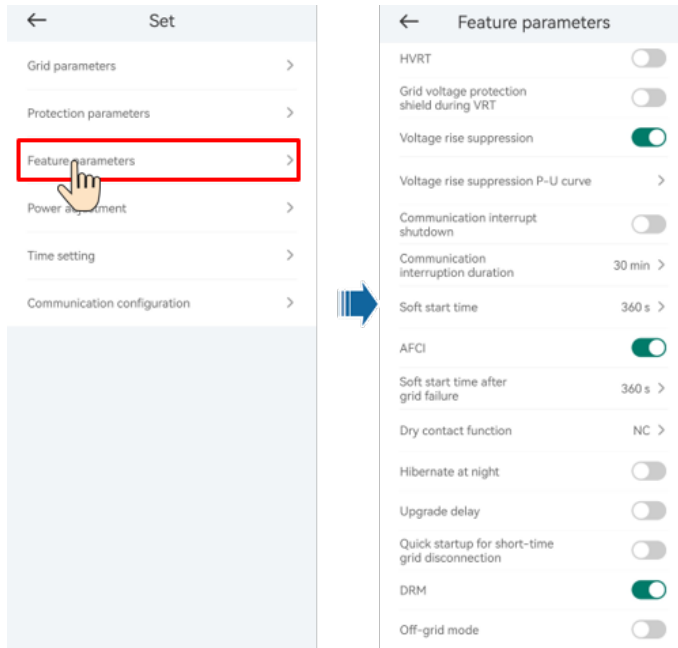

---End

8 Maintenance

 DANGER

- Wear personal protective equipment and use dedicated insulated tools to avoid electric shocks or short circuits.
-

 WARNING

- Before performing maintenance, power off the equipment, follow the instructions on the delayed discharge label, and wait for a period of time as specified to ensure that the equipment is not energized.
-

8.1 System Power-Off

Precautions

 WARNING

After the ISTORE powers off, the remaining electricity and heat may still cause electric shocks and body burns. Therefore, put on protective gloves and begin operating the ISTORE five minutes after the power-off.

Procedure

- Step 1** Send a shutdown command on the app.
- Step 2** Turn off the AC switch between the ISTORE and the power grid.
- Step 3** Turn off the DC switch at the bottom of the ISTORE.
- Step 4** (Optional) Install the locking screw for the DC switch.

Figure 8-1 Installing the locking screw for the DC switch

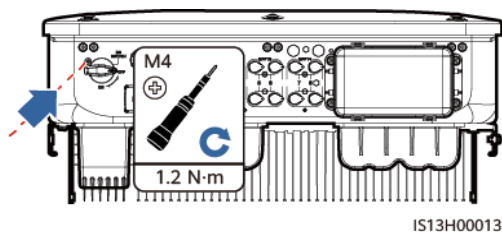

Step 5 Turn on the DC switch between the PV string and the ISTORE if there is any.

---End

8.2 Routine Maintenance

To ensure that the ISTORE can operate properly for a long term, you are advised to perform routine maintenance on it as described in this chapter.

⚠ CAUTION

Before cleaning the system, connecting cables, and ensuring the grounding reliability, power off the system.

Table 8-1 Maintenance checklist

Check Item	Check Method	Maintenance Interval
System cleanliness	Check periodically that the heat sinks are free from obstacles and dust.	Once every 6 to 12 months
System operating status	<ul style="list-style-type: none"> Check that the ISTORE is not damaged or deformed. Check that the ISTORE operates with no abnormal sound. Check that all ISTORE parameters are correctly set during operation. 	Once every 6 months
Electrical connection	<ul style="list-style-type: none"> Check that cables are secured. Check that cables are intact, and that in particular, the parts touching the metallic surface are not scratched. 	The first inspection is 6 months after the initial commissioning. From then on, the interval can be 6 to 12 months.
Grounding reliability	Check that ground cables are securely connected.	The first inspection is 6 months after the initial commissioning. From then on, the interval can be 6 to 12 months.

Check Item	Check Method	Maintenance Interval
Air tightness	Check that all terminals and ports are properly sealed.	Once a year
Clear vegetation around the inverters	<ul style="list-style-type: none"> Perform inspection and weeding as required. Clean the site promptly after weeding. 	Based on the local wilting season

8.3 Troubleshooting

Alarm severities are defined as follows:

- Major: The inverter is faulty. As a result, the output power decreases or the grid-tied power generation is stopped.
- Minor: Some components are faulty without affecting the grid-tied power generation.
- Warning: The inverter works properly. The output power decreases or some authorization functions fail due to external factors.

Table 8-2 Common fault alarm list

ID	Name	Severity	Cause	Solution
2001	High string input voltage	Major	<p>The PV array is not properly configured. Excessive PV modules are connected in series to the PV string, and therefore the PV string open-circuit voltage exceeds the maximum inverter operating voltage.</p> <ul style="list-style-type: none"> • Cause ID 1: PV strings 1 and 2 • Cause ID 2: PV strings 3 and 4 • Cause ID 3: PV strings 5 and 6 • Cause ID 4: PV strings 7 and 8 	Reduce the number of PV modules connected in series to the PV string until the PV string open-circuit voltage is less than or equal to the maximum inverter operating voltage. After the PV string configuration is corrected, the alarm disappears.
2002	DC arc fault	Major	<p>The PV string power cables arc or are in poor contact.</p> <ul style="list-style-type: none"> • Cause ID 1: PV strings 1 and 2 • Cause ID 2: PV strings 3 and 4 • Cause ID 3: PV strings 5 	Check whether the PV string cables arc or are in poor contact.

ID	Name	Severity	Cause	Solution
			and 6 <ul style="list-style-type: none"> • Cause ID 4: PV strings 7 and 8 	
2003	DC arc fault	Major	The PV string power cables arc or are in poor contact. Cause ID 1–8: PV strings 1–8	Check whether the PV string cables arc or are in poor contact.
2009	String Short-Circuited to Ground	Major	1. The PV array is short-circuited to ground. 2. The ambient environment of PV arrays is moist.	1. Check the output-to-ground impedance of the PV array. If a short circuit or inadequate insulation is detected, rectify it. 2. If auto recovery from string-to-ground short-circuit protection is disabled, check and rectify the preceding faults, and manually clear the alarm. 3. If auto recovery from string-to-ground short-circuit protection is enabled, the alarm will be automatically cleared after fault recovery.
2011	String reverse connection	Major	The PV string polarity is reversed. Cause ID 1–8: PV strings 1–8	1. Check whether the PV string is connected to the device in reverse polarity. If yes, wait until the PV string current decreases to below 0.5 A, set DC SWITCH to OFF, and adjust the PV string polarity. 2. If the fault persists, reset the device on the local maintenance app or WebUI of the upper-layer controller. Alternatively, you can turn off the AC and DC switches, wait for 5 minutes, and then turn on the AC and DC switches.
2012	String current backfeed	Warning	The number of PV modules connected in series to the PV string is insufficient. As a result, the terminal voltage is lower than that of other strings. Cause ID 1–8: PV strings 1–8	1. Check whether the number of PV modules connected in series to the PV string is less than that of other PV strings. If yes, wait until the PV string current drops below 0.5 A, turn off all DC switches, and adjust the number of PV modules in the PV string. 2. Check whether the open-circuit voltage of the PV string is abnormal. 3. Check whether the PV string is shaded.

ID	Name	Severity	Cause	Solution
2021	AFCI self-check failure	Major	Cause ID = 1, 2 The AFCI self-check fails.	Turn off the AC output switch and DC input switch, and then turn them on after 5 minutes. If the alarm persists, contact ISTORE technical support.
2031	Phase wire short-circuited to PE	Major	Cause ID = 1 The impedance of the output phase wire to PE is low or the output phase wire is short-circuited to PE.	Check the impedance of the output phase wire to PE, locate the position with low impedance, and rectify the fault.
2032	Grid loss	Major	Cause ID = 1 <ul style="list-style-type: none"> Power grid outage occurs. The AC circuit is disconnected or the AC switch is off. 	<ol style="list-style-type: none"> The alarm is cleared automatically after the power grid recovers. Check whether the AC circuit is disconnected or the AC switch is off.
2033	Grid undervoltage	Major	Cause ID = 1 The power grid voltage is below the lower threshold or the low-voltage duration has lasted for more than the value specified by LVRT.	<ol style="list-style-type: none"> If the alarm occurs occasionally, the power grid may be abnormal temporarily. The inverter automatically recovers after detecting that the power grid becomes normal. If the alarm persists, check whether the power grid voltage is within the acceptable range. If not, contact the local power operator. If yes, modify the grid undervoltage protection threshold through the app, Logger, or NMS with the consent of the local power operator. If the alarm persists for a long time, check the AC circuit breaker and AC output power cable.
2034	Grid overvoltage	Major	Cause ID = 1 The power grid voltage exceeds the upper threshold or the high voltage duration has lasted for more than the value specified by HVRT.	<ol style="list-style-type: none"> If the alarm occurs occasionally, the power grid may be abnormal temporarily. The device automatically recovers after detecting that the power grid becomes normal. If the alarm occurs frequently, check whether the power grid voltage is within the allowed range. If not, contact the local power operator. If yes, modify the power grid overvoltage protection threshold after obtaining the consent of the local

ID	Name	Severity	Cause	Solution
				<p>power operator.</p> <p>3. Check whether the peak voltage of the power grid is too high. If the fault occurs frequently and persists for a long time, contact the local power operator.</p>
2035	Grid volt. Imbalance	Major	<p>Cause ID = 1</p> <p>The difference between power grid phase voltages exceeds the upper threshold.</p>	<p>1. If the alarm occurs occasionally, the power grid may be abnormal temporarily. The inverter automatically recovers after detecting that the power grid becomes normal.</p> <p>2. If the alarm persists, check whether the power grid voltage is within the acceptable range. If not, contact the local power operator.</p> <p>3. If the alarm lasts for a long time, check the AC output power cable connection.</p> <p>4. If the AC output power cable is correctly connected, yet the alarm persists and affects the energy yield of the PV plant, contact the local power operator.</p>
2036	Grid overfrequency	Major	<p>Cause ID = 1</p> <p>Power grid exception: The actual power grid frequency is higher than the requirements for the local power grid code.</p>	<p>1. If the alarm occurs occasionally, the power grid may be abnormal temporarily. The inverter automatically recovers after detecting that the power grid becomes normal.</p> <p>2. If the alarm persists, check whether the power grid frequency is within the acceptable range. If not, contact the local power operator. If yes, modify the grid overfrequency protection threshold through the app, IS-LOGGER, or NMS with the consent of the local power operator.</p>
2037	Grid underfrequency	Major	<p>Cause ID = 1</p> <p>Power grid exception: The actual power grid frequency is lower than the requirements for the local power grid code.</p>	<p>1. If the alarm occurs occasionally, the power grid may be abnormal temporarily. The inverter automatically recovers after detecting that the power grid becomes normal.</p> <p>2. If the alarm persists, check whether the power grid frequency is within the acceptable range. If not, contact</p>

ID	Name	Severity	Cause	Solution
				the local power operator. If yes, modify the grid underfrequency protection threshold through the app, IS-LOGGER, or NMS with the consent of the local power operator.
2038	Unstable grid frequency	Major	Cause ID = 1 Power grid exception: The actual change rate of the power grid frequency does not meet the requirements for the local power grid code.	<ol style="list-style-type: none"> 1. If the alarm occurs occasionally, the power grid may be abnormal temporarily. The inverter automatically recovers after detecting that the power grid becomes normal. 2. If the alarm persists, check whether the power grid frequency is within the acceptable range. If not, contact the local power operator.
2039	AC Overcurrent	Major	Cause ID = 1 The grid experiences a dramatic voltage drop or is short-circuited. As a result, the transient AC current of the device exceeds the upper threshold and triggers protection.	<ol style="list-style-type: none"> 1. The device detects its external working conditions in real time. After the fault is rectified, the device automatically recovers. 2. If the alarm occurs frequently and affects the operation of the power plant, check whether AC short circuit exists. If the fault persists, contact your dealer or technical support.
2040	Output DC component overhigh	Major	Cause ID = 1 The DC component of the inverter output current exceeds the upper threshold.	<ol style="list-style-type: none"> 1. The inverter monitors its external operating conditions in real time and automatically recovers after the fault is rectified. 2. If the alarm persists and affects the energy yield of the PV plant, contact your dealer or ISTORE technical support.
2051	Abnormal residual current	Major	Cause ID = 1 The insulation impedance of the input side to PE decreases when the inverter is operating.	<ol style="list-style-type: none"> 1. If the alarm occurs accidentally, the external power cable may be abnormal temporarily. The inverter automatically recovers after the fault is rectified. 2. If the alarm persists or lasts a long time, check whether the impedance between the PV string and ground is too low.
2061	Abnormal grounding	Major	Cause ID = 1 <ul style="list-style-type: none"> • The neutral wire or PE cable of the inverter is not connected. 	Power off the inverter (turn off the AC output switch and DC input switch, and wait for a period of time. For details about the wait time, see the description on the

ID	Name	Severity	Cause	Solution
			<ul style="list-style-type: none"> The output mode set for the inverter is inconsistent with the cable connection mode. 	<p>device safety warning label), and then perform the following operations:</p> <ol style="list-style-type: none"> 1. Check whether the PE cable for the inverter is connected properly. 2. If the inverter is connected to a TN power grid, check whether the neutral wire is properly connected and whether the voltage of the neutral wire to ground is normal. 3. After the inverter is powered on, check whether the output mode set for the inverter is consistent with the output cable connection mode.
2062	Low insulation resistance	Major	<p>Cause ID = 1</p> <ul style="list-style-type: none"> The PV array is short-circuited with PE. The PV string has been in a moist environment for a long time and the circuit is not well insulated to ground. 	<ol style="list-style-type: none"> 1. Check the impedance between the PV string and the PE cable. If a short circuit occurs, rectify the fault. 2. Check whether the PE cable of the inverter is correctly connected. 3. If you have confirmed that the impedance is lower than the specified protection threshold in a cloudy or rainy environment, log in to the app, IS-LOGGER, or NMS and set Insulation resistance protection threshold.
2063	Cabinet overtemperature	Minor	<p>Cause ID = 1</p> <ul style="list-style-type: none"> The inverter is installed in a place with poor ventilation. The ambient temperature exceeds the upper threshold. The inverter is not operating properly. 	<ol style="list-style-type: none"> 1. Check the ventilation and ambient temperature at the inverter installation position. 2. If the ventilation is poor or the ambient temperature exceeds the upper threshold, improve the ventilation and heat dissipation. 3. If both the ventilation and ambient temperature meet requirements yet the alarm persists, contact your dealer or ISTORE technical support.
2064	Device fault	Major	<p>Cause ID = 1–15</p> <p>An unrecoverable fault occurs on a circuit inside the inverter.</p>	<p>Turn off the AC output switch and DC input switch, and then turn them on after 5 minutes. If the alarm persists, contact your dealer or ISTORE technical support.</p>

ID	Name	Severity	Cause	Solution
				<p>NOTICE</p> <p>Cause ID = 1: Perform the preceding operations when the PV string current is less than 1 A.</p>
2065	Upgrade failed or version mismatch	Minor	<p>Cause ID = 1–6</p> <p>The upgrade is not completed normally.</p>	<ol style="list-style-type: none"> 1. Perform an upgrade again. 2. If the upgrade fails several times, contact your dealer or ISTORE technical support.
2066	License expired	Warning	<p>Cause ID = 1</p> <ul style="list-style-type: none"> • The privilege license has entered the grace period. • The privilege feature is about to expire. 	<ol style="list-style-type: none"> 1. Apply for a new license. 2. Load a new certificate.
2067	Faulty power collector	Major	<p>Cause ID = 1</p> <p>The power meter is disconnected.</p>	<ol style="list-style-type: none"> 1. Check whether the configured power meter model is the same as the actual model. 2. Check whether the communications parameters of the power meter are the same as the RS485 configurations of the inverter. 3. Check whether the power meter is powered on and whether the RS485 communications cable is connected.
61440	Faulty monitoring unit	Minor	<p>Cause ID = 1</p> <ul style="list-style-type: none"> • The flash memory is insufficient. • The flash memory has bad sectors. 	<p>Turn off the AC output switch and DC input switch, and then turn them on after 5 minutes. If the alarm persists, replace the monitoring board or contact your dealer or ISTORE technical support.</p>
2072	Transient AC overvoltage	Major	<p>Cause ID = 1</p> <p>The inverter detects that the phase voltage exceeds the transient AC overvoltage protection threshold.</p>	<ol style="list-style-type: none"> 1. If the voltage at the grid connection point is too high, contact the local power operator. 2. If you have confirmed that the voltage at the grid connection point exceeds the upper threshold and obtained consent from the local power operator, modify the overvoltage protection thresholds. 3. Check whether the peak grid voltage exceeds the upper threshold.
2080	Abnormal PV module configuration	Major	<ul style="list-style-type: none"> • Cause ID = 1 <p>The number of 3rd party optimizers connected to the inverter exceeds the</p>	<p>Check whether the total number of PV modules, number of PV modules in a PV string, and number of PV strings meet requirements and whether the PV module output is</p>

ID	Name	Severity	Cause	Solution
	tion		<p>upper threshold.</p> <ul style="list-style-type: none"> • Cause ID = 2 The PV string power or the number of 3rd party optimizers connected in series in a PV string exceeds the upper threshold. • Cause ID = 3 The number of 3rd party optimizers connected in series in a PV string is less than the lower threshold, the PV string output is reversely connected, or the output of some 3rd party optimizers in the PV string is reversely connected. • Cause ID = 4 The number of PV strings connected to the inverter exceeds the upper threshold. • Cause ID = 5 The PV string output is reversely connected or the PV string output is short-circuited. • Cause ID = 6 Under the same MPPT, the number of 3rd party optimizers connected in series in PV strings connected in parallel is different, or the output of some 3rd party optimizers in PV strings is reversely connected. • Cause ID = 7 The 3rd party optimizer installation position is changed, or PV strings are combined or exchanged. • Cause ID = 8 The sunlight is weak or changes abnormally. • Cause ID = 9 In partial configuration 	<p>reversely connected.</p> <ul style="list-style-type: none"> • Cause ID 1: Check whether the total number of 3rd party optimizers exceeds the upper threshold. • Cause ID 2: Check whether the PV string power or the number of PV strings connected in series exceeds the upper threshold. • Cause ID 3: <ol style="list-style-type: none"> 1. Check whether the number of 3rd party optimizers connected in series in the PV string is below the lower threshold. 2. Check whether the PV string output is reversely connected. 3. Check whether the PV string output is disconnected. 4. Check whether the 3rd party optimizer output extension cable is correct (positive connector at one end and negative connector at the other). • Cause ID 4: Check whether the number of PV strings exceeds the upper threshold. • Cause ID 5: Check whether the PV string output is reversely connected or short-circuited. • Cause ID 6: <ol style="list-style-type: none"> 1. Check whether the number of 3rd party optimizers connected in series in the PV strings connected in parallel under the same MPPT is the same. 2. Check whether the 3rd party optimizer output extension cable is correct (positive connector at one end and negative connector at the other). • Cause ID 7: When the sunlight is normal, perform the 3rd party optimizer search function again. • Cause ID 8: When the sunlight is normal, perform the 3rd party

ID	Name	Severity	Cause	Solution
			scenarios, the PV string voltage exceeds the inverter input voltage specifications.	optimizer search function again. <ul style="list-style-type: none"> • Cause ID 9: Calculate the PV string voltage based on the number of PV modules in the string and check whether the string voltage exceeds the upper threshold of the inverter input voltage.
2085	Built-in PID operation abnormal	Minor	Cause ID = 1, 2 <ul style="list-style-type: none"> • The output resistance of PV arrays to ground is low. • The system insulation resistance is low. 	<ul style="list-style-type: none"> • Cause ID = 1 <ol style="list-style-type: none"> 1. Turn off the AC output switch and DC input switch, wait for a period of time (for details about the wait time, see the description on the device safety warning label), and then turn on the DC input switch and AC output switch. 2. If the alarm persists, contact your dealer or ISTORE technical support. • Cause ID = 2 <ol style="list-style-type: none"> 1. Check the impedance between the PV array output and the ground. If a short circuit occurs or the insulation is insufficient, rectify the fault. 2. If the alarm persists, contact your dealer or ISTORE technical support.
2090	Abnormal active power scheduling instruction	Major	Cause ID = 1 <ul style="list-style-type: none"> • The DI input is abnormal. • The DI input is inconsistent with the configuration. 	<ol style="list-style-type: none"> 1. Check whether the cables are connected correctly to the DI ports. 2. On the DI active scheduling screen under the dry contact scheduling settings, view the DI signal configuration mapping table. Contact the power grid company to check whether the configurations in the mapping table are complete and meet the requirements.
2091	Abnormal reactive power scheduling instruction	Major	Cause ID = 1 <ul style="list-style-type: none"> • The DI input is abnormal. • The DI input is inconsistent with the configuration. 	<ol style="list-style-type: none"> 1. Check whether the cables are connected correctly to the DI ports. 2. On the DI reactive power scheduling screen under the dry contact scheduling settings, view the DI signal configuration

ID	Name	Severity	Cause	Solution
				mapping table. Contact the power grid company to check whether the configurations in the mapping table are complete and meet the requirements.

 NOTE

Contact your dealer or ISTORE technical support if all troubleshooting procedures listed above are completed and the fault still exists.

Contact your dealer for list of compatible 3rd party Optimizers.

9 Handling the Inverter

9.1 Removing the ISTORE

NOTICE

Before removing the ISTORE, disconnect both AC and DC connections.

Perform the following operations to remove the ISTORE:

1. Disconnect all cables from the ISTORE, including RS485 communications cables, DC input power cables, AC output power cables, and PGND cables.
2. Remove the ISTORE from the mounting bracket.
3. Remove the mounting bracket.

9.2 Packing the ISTORE

- If the original packing materials are available, put the ISTORE inside them and then seal them by using adhesive tape.
- If the original packing materials are not available, put the ISTORE inside a suitable cardboard box and seal it properly.

9.3 Disposing of the ISTORE

If the ISTORE service life expires, dispose of it according to the local disposal rules for electrical equipment waste.

10 Technical Specifications

Efficiency

Technical Specifications	IS-INV-29900-3PH	IS-INV-40000-3PH
Peak efficiency	98.65%/400 V	98.65%/400 V
European efficiency	98.4%/400 V	98.4%/400 V

Input

Technical Specifications	IS-INV-29900-3PH	IS-INV-40000-3PH
Recommended maximum DC input power	44,850 W	60,000 W
Maximum input voltage ^a	1100 V	
Maximum input current (per MPPT)	27 A	
Maximum short-circuit current (per MPPT)	40 A	
Backfeed short-circuit current (per MPPT)		
Minimum startup voltage	200 V	
MPP voltage range	200–1000 V	
Full power MPPT voltage range ^b	500–800 V (400 V AC)	540–800 V (400 V AC)
Rated input voltage	600 V (400 V AC)	600 V (400 V AC)
Maximum number of inputs	8	

Technical Specifications	IS-INV-29900-3PH	IS-INV-40000-3PH
Number of MPPTs	4	
<p>Note a: The maximum input voltage is the maximum DC input voltage that the ISTORE can withstand. If the input voltage exceeds this value, the ISTORE may be damaged.</p> <p>Note b: PV strings connecting to the same MPPT must contain the same quantity and model of PV modules. It is recommended that the PV string voltage be higher than the lower threshold of the full-load MPPT voltage.</p>		

Output

Technical Specifications	IS-INV-29900-3PH	IS-INV-40000-3PH
Rated output power	29,900 W	40,000 W
Maximum apparent power	29,900 VA	44,000 VA
Maximum active power (cosφ = 1)	29,900 W	44,000 W
Rated output voltage	230 V AC (400 V AC), 3W/N+PE	230 V AC (400 V AC), 3W/N+PE
Maximum output voltage at long-term operation	See standards about the local power grid.	
Rated output current	43.2 A (400 V AC)	57.8 A (400 V AC)
Maximum output current	43.2 A (400 V AC)	63.8 A (400 V AC)
Output voltage frequency	50 Hz/60 Hz	
Power factor	0.8 leading–0.8 lagging	
Output DC component DCI	< 0.5% of the rated output	
Maximum total harmonic distortion (THD) AC THDi	< 3% under rated conditions.	

Protection

Technical Specifications	IS-INV-29900-3PH	IS-INV-40000-3PH
Overvoltage category	PV II/AC III	
Input DC switch	Supported	
Islanding protection	Supported	

Technical Specifications	IS-INV-29900-3PH	IS-INV-40000-3PH
Output overcurrent protection	Supported	
Input reverse connection protection	Supported	
String fault detection	Supported	
DC surge protection	Type II	
AC surge protection	Type II	
Insulation resistance detection	Supported	
Residual current monitoring unit (RCMU)	Supported	

Display and Communication

Technical Specifications	IS-INV-29900-3PH	IS-INV-40000-3PH
Display	LED indicator; WLAN+app	
RS485	Supported	
Built-in WLAN	Supported	
DC MBUS	Supported	
AFCI	Supported	
PID	Supported	

General Specifications

Technical Specifications	IS-INV-29900-3PH	IS-INV-40000-3PH
Dimensions (W x H x D)	640 mm x 530 mm x 270 mm	
Net Weight	43 kg	
Operating temperature	-25°C to +60°C (derated when the temperature is above +45°C)	
Humidity	0%–100%	
Cooling mode	Natural cooling	
Maximum operating altitude	0–4000 m	

Technical Specifications	IS-INV-29900-3PH	IS-INV-40000-3PH
Storage temperature	-40°C to +70°C	
IP rating	IP66	
Topology	Transformerless	
Pollution degree classification	PD3 (internal reduced to PD2)	

Wireless Communication Parameters

Specifications	Inverter Built-in WiFi	WLAN-FE Smart Dongle
Frequency	2400–2483.5 MHz	IS-DONGLE-WLAN: 2400–2483.5 MHz
Protocol standard	WLAN 802.11b/g/n	IS-DONGLE-WLAN: WLAN 802.11b/g/n
Bandwidth	20 MHz/40 MHz (optional)	20 MHz/40 MHz (optional)
Maximum transmit power	≤ 20 dBm EIRP	≤ 20 dBm EIRP

A Grid Codes

NOTE

The grid codes are subject to change. The listed codes are for reference only.

For Australian market, to comply with AS/NZS 4777.2:2020 please select from Region A/B/C (AUSTRALIA-AS4777-A/B/C-LV230). Please contact your local grid operator for which region to select.

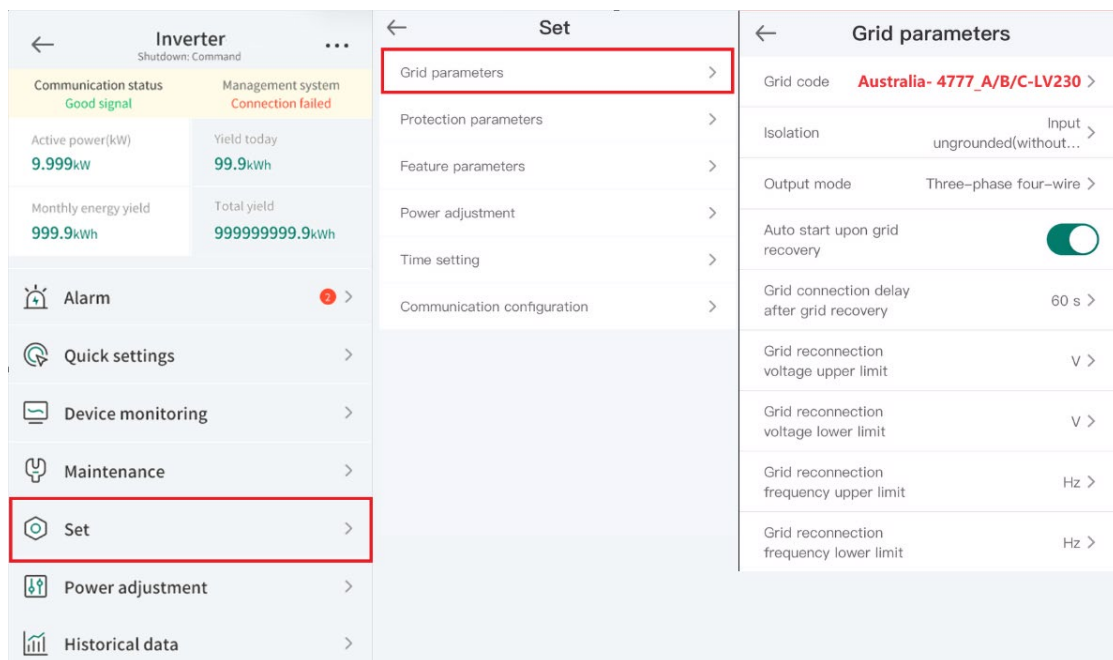

National/ Regional Grid Code	Description	IS-INV- 29900-3PH	IS-INV- 40000-3PH
AUSTRALIA- AS4777_A-LV230	Australia power grid connection standard (AS/NZS 4777.2:2020)	Supported	Supported
AUSTRALIA- AS4777_B-LV230	Australia power grid connection standard (AS/NZS 4777.2:2020)	Supported	Supported

National/ Regional Grid Code	Description	IS-INV- 29900-3PH	IS-INV- 40000-3PH
AUSTRALIA- AS4777_C-LV230	Australia power grid connection standard (AS/NZS 4777.2:2020)	Supported	Supported
AUSTRALIA- AS4777_NZ-LV230	New Zealand power grid connection standard (AS/NZS 4777.2:2020)	Supported	Supported
AS4777	New Zealand and Australia power grid connection standard (AS/NZS 4777.2:2015)	Supported	Supported
N/A	-	-	-

B Device Commissioning

Step 1 Connect to the solar inverter WLAN and log in to the device commissioning screen as the **installer** user.

NOTICE

- If the mobile phone is directly connected to the inverter, the visible distance between the inverter and the mobile phone must be less than 3 m when a built-in antenna is used and less than 50 m when an external antenna is used to ensure the communication quality between the App and the inverter. The distances are for reference only and may vary with mobile phones and shielding conditions.
- When connecting the inverter to the WLAN over a router, ensure that the mobile phone and inverter are in the WLAN coverage of the router and the inverter is connected to the router.
- The router supports WLAN (IEEE 802.11 b/g/n, 2.4 GHz) and the WLAN signal reaches the inverter.
- The WPA, WPA2, or WPA/WPA2 encryption mode is recommended for routers. Enterprise-level encryption is not supported (for example, public hotspots requiring authentication such as airport WLAN). WEP and WPA TKIP are not recommended because these two encryption modes have serious security defects. If the access fails in WEP mode, log in to the router and change the encryption mode of the router to WPA2 or WPA/WPA2.

NOTE

- Obtain the initial password for connecting to the solar inverter WLAN from the label on the side of the solar inverter.
- Set the password at the first login. To ensure account security, change the password periodically and keep the new password in mind. Not changing the initial password may cause password disclosure. A password left unchanged for a long period of time may be stolen or cracked. If a password is lost, devices cannot be accessed. In these cases, the user is liable for any loss caused to the PV plant.
- When you access the **device commission** screen of the inverter for the first time, you need to manually set the login password because the inverter does not have an initial login password.

----End

C Setting Power Adjustment Parameters

Prerequisite:

You have logged in to the HiSolar app as installer.

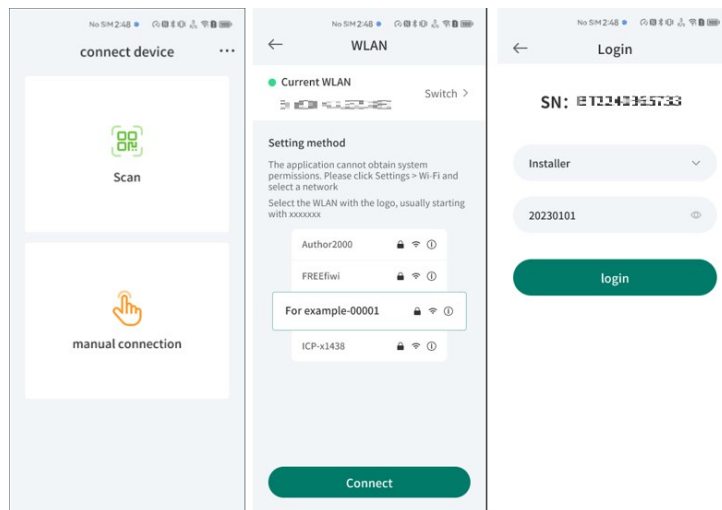

Export Limit:

From Main Page, Select Power adjustment → Feature parameters → Grid-tied point control → Active Power Set the export limit as required

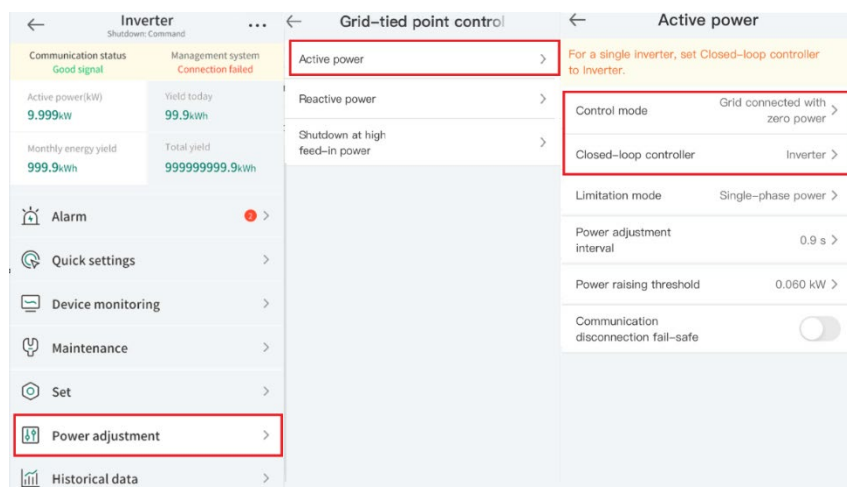

P-U Setting:

From Main Page, Select Set → Feature parameters → enable ‘Voltage rise suppression’ → Set the Curve points → set the value U and P/Pn accordingly with the value provided by grid operator and Submit:

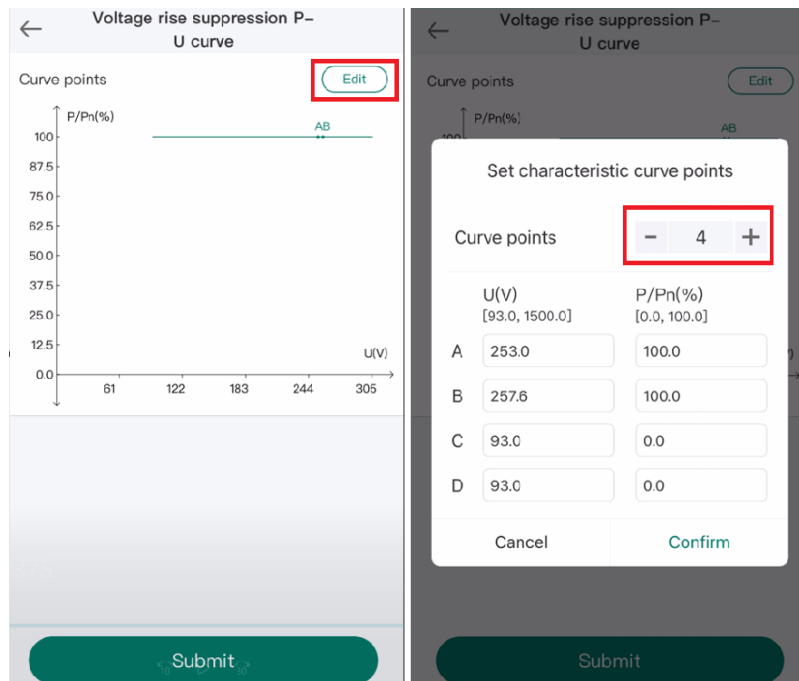
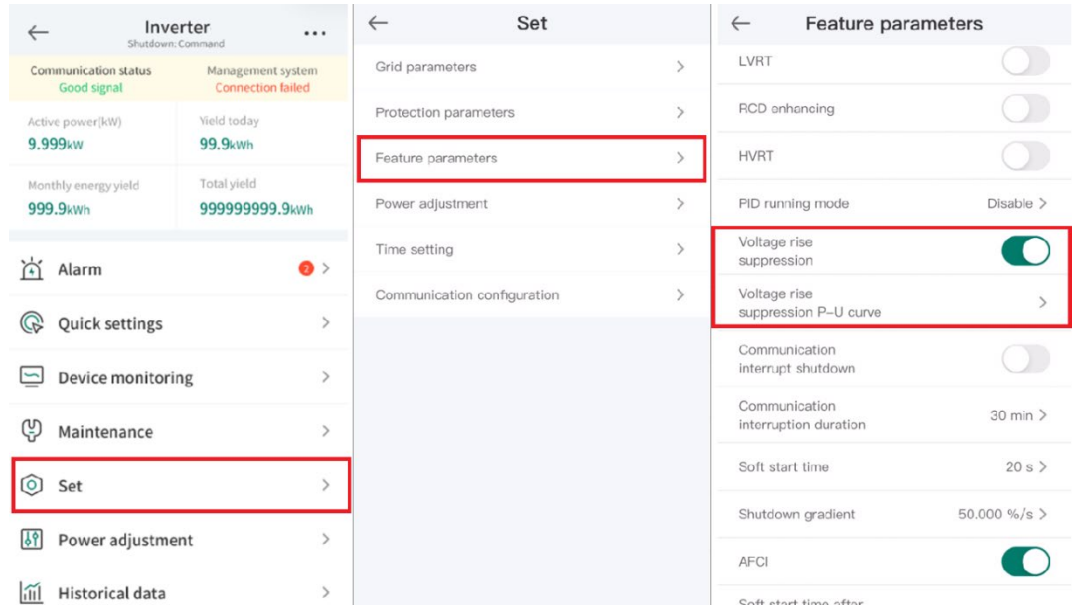

Q-U Setting

From Main Page, Select Set → Power adjustment → select ‘Q-U characteristic curve’ → Set the Curve points → set the value U and Q/S accordingly with the value provided by grid operator and Submit:

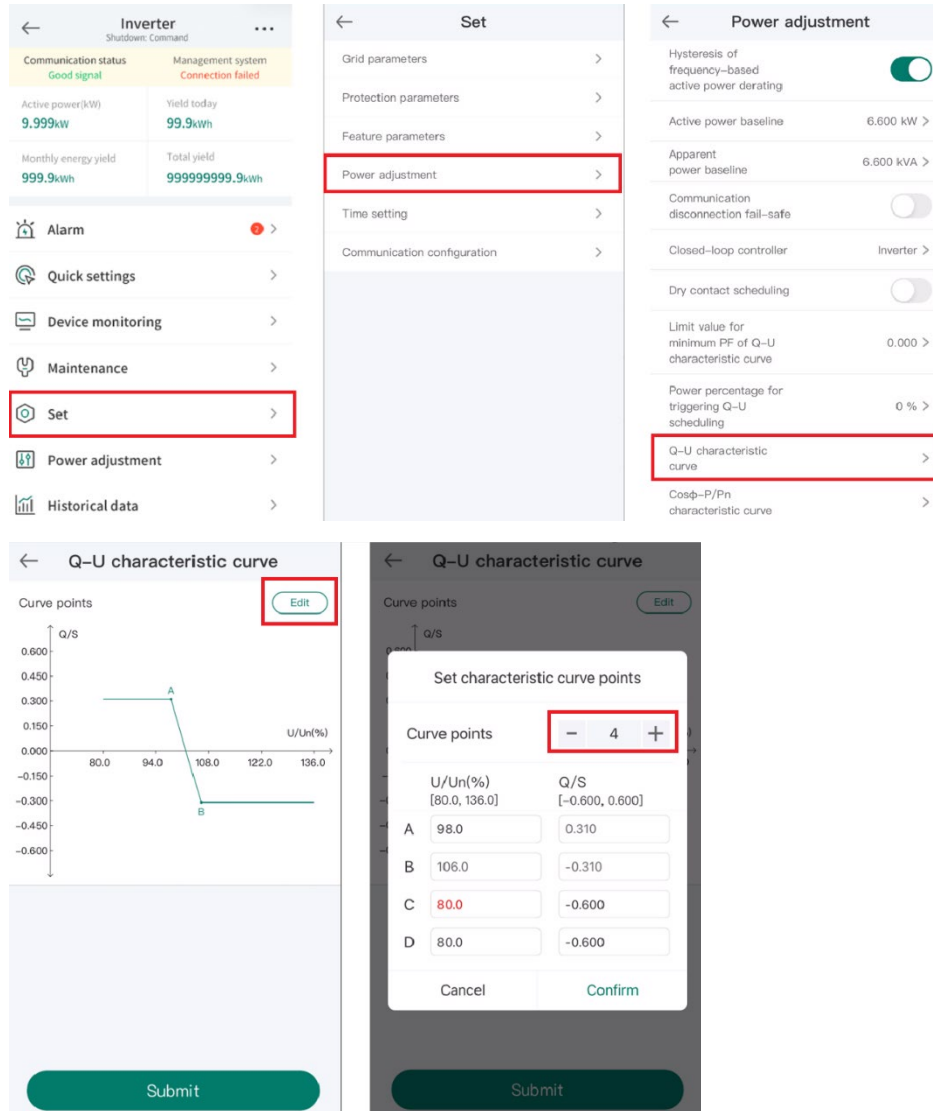

----End

D Rapid Shutdown

When all PV modules connected to the solar inverter are configured with compatible 3rd party optimizers approved by ISTORE Energy, the PV system shuts down quickly and reduces the output voltage of the PV string. If 3rd party optimizers are configured for some PV modules, the rapid shutdown function is not supported

Triggering methods of rapid shutdown:

- Method 1 (recommended): Turn off the AC switch between the inverter and the power grid.
- Method 2: Turn off the DC switch at the bottom of the inverter.
- Method 3: If the DIN5 port (port 15) of the inverter communications terminal is connected to a rapid shutdown button, press the button to trigger rapid shutdown.

 **NOTE**





Log in to the App as an installer, choose **Me > Device Commissioning**, and connect to the WLAN hotspot of the ISTORE. Log in to the local commissioning system as an installer user, choose **Settings > Feature parameters > Dry contact function**, and set **Dry contact function** to **DI rapid shutdown**.

- Method 4: If **AFCI** is enabled, the inverter automatically detects arc faults, triggering a rapid shutdown.

 **NOTE**

Contact your dealer for list of compatible 3rd party Optimizers.

E Resetting Password

- Step 1** Check that the AC and DC power supplies to the solar inverter are connected simultaneously, and that the  and  indicators are steady green or blink slowly for more than 3 minutes.
- Step 2** Turn off the AC switch, set the DC switch at the bottom of the solar inverter to OFF, and wait until all indicators on the solar inverter panel turn off.
- Step 3** Complete the following operations within 3 minutes:
1. Turn on the AC switch and wait until the  indicator blinks.
 2. Turn off the AC switch and wait until all indicators on the solar inverter panel turn off.
 3. Turn on the AC switch and wait until all LED indicators on the inverter panel blink and turn off after about 30s.
- Step 4** Wait until the three indicators on the inverter panel blink green quickly and then blink red quickly, indicating that the password has been restored.
- Step 5** Reset the password within 10 minutes. (If no operation is performed within 10 minutes, all parameters of the solar inverter remain the same as those before the reset.)
1. Wait until the  indicator blinks.
 2. Obtain the initial WLAN hotspot name (SSID) and initial password (PSW) from the label on the side of the solar inverter to connect to the app.
 3. On the login page, set a new login password and log in to the app.
- Step 6** Set router and management system parameters to implement remote management.

---End

NOTICE

You are advised to reset the password in the morning or at night when the solar irradiance is low.

F Locating Insulation Resistance Faults

If the ground impedance of a PV string connected to the inverter is too low, the inverter generates a **Low insulation resistance** alarm.

The possible causes are as follows:

- A short circuit has occurred between the PV array and the ground.
- The ambient air of the PV array is damp and the insulation between the PV array and the ground is poor.

After the **Low insulation resistance** alarm is reported by the inverter, insulation resistance fault location is automatically triggered. If the fault location is successful, the location information is displayed on the **Alarm details** screen of the **Low insulation resistance** alarm on the monitoring app.

Log in to the app, choose **Alarm > Active alarm**, select **Low insulation resistance** to enter the **Alarm details** screen.

NOTE

- The positive and negative terminals of a PV string are respectively connected to the PV+ and PV– terminals of the inverter. The PV– terminal represents a possibility of 0% for the short-circuit position and the PV+ terminal represents a possibility of 100% for the short-circuit position. Other percentages indicate that the fault occurs on a PV module or cable in the PV string.
- Possible fault position = Total number of PV modules in a PV string x Percentage of possible short-circuit positions. For example, if a PV string consists of 14 PV modules and the percentage of the possible short-circuit position is 34%, the possible fault position is 4.76 (14 x 34%), indicating that the fault is located near PV module 4, including the previous and the next PV modules and the cables. The inverter has a detection precision of ± 1 PV module.
- The possible faulty PV string MPPT1 corresponds to PV1 and PV2, and the possible faulty PV string MPPT2 corresponds to PV3 and PV4. The fault can be located only to the MPPT level. Perform the following steps to connect the PV strings corresponding to the faulty MPPT to the inverter one by one to further locate and rectify the fault.
- When a non-short-circuit fault occurs, the possible short-circuit percentage is not displayed. If the insulation resistance is greater than $0.001 \text{ M}\Omega$, the fault is not related to short circuit. Check all PV modules in the faulty PV string one by one to locate and rectify the fault.

Procedure

NOTICE

If the irradiance or the PV string voltage is too high, the insulation resistance fault location may fail. In this case, the fault location status on the **Alarm details** screen is **Conditions not met**. Perform the following steps to connect PV strings to the inverter one by one to locate the fault. If the system is not configured with any 3rd party optimizer, skip the corresponding 3rd party optimizer operations.

- Step 1** Ensure that the AC connections are normal. Log in to the app, choose **Maintenance > Inverter ON/OFF** on the home screen, and send a shutdown command. Set **DC SWITCH** to **OFF**.
- Step 2** Connect one PV string to the inverter, and set **DC SWITCH** to **ON**. If the inverter status is **Shutdown: Command**, log in to the app, choose **Maintenance > Inverter ON/OFF** on the home screen, and send a startup command.
- Step 3** Choose **Alarm** on the home screen, enter the **Active alarm** screen, and check whether a **Low insulation resistance** alarm is reported.
- If no **Low insulation resistance** alarm is reported 1 minute after the DC side is powered on, choose **Maintenance > Inverter ON/OFF** on the home screen, and send a shutdown command. Set **DC SWITCH** to **OFF**. Go to [Step 2](#) and check rest of the PV strings one by one.
 - If a **Low insulation resistance** alarm is reported 1 minute after the DC side is powered on, check the percentage of possible short-circuit positions on the **Alarm details** screen and calculate the location of the possible faulty PV module based on the percentage. Then go to [Step 4](#).
- Step 4** Log in to the app, choose **Maintenance > Inverter ON/OFF** on the home screen, and send a shutdown command. Set **DC SWITCH** to **OFF**. Check whether the connectors or DC power cables between the 3rd party optimizer and PV module, between adjacent PV modules, or between adjacent 3rd party optimizers on the possible fault position are damaged.
- If yes, replace the damaged connectors or DC power cables, and then set **DC SWITCH** to **ON**. If the inverter status is **Shutdown: Command**, choose **Maintenance > Inverter ON/OFF**, and send a startup command. View alarm information.
 - If no **Low insulation resistance** alarm is reported 1 minute after the DC side is powered on, troubleshoot the insulation resistance fault of the PV string. Log in to the app, choose **Maintenance > Inverter ON/OFF** on the home screen, and send a shutdown command. Set **DC SWITCH** to **OFF**. Go to [Step 2](#) and check rest of the PV strings one by one. Then, go to [Step 8](#).
 - If the DC side is powered on 1 minute later, the **Low insulation resistance** alarm is still reported. Log in to the app, choose **Maintenance > Inverter ON/OFF** on the home screen, and send a shutdown command. Set **DC SWITCH** to **OFF** and go to [Step 5](#).
 - If no, go to [Step 5](#).
- Step 5** Disconnect the possible faulty PV module and the paired 3rd party optimizer from the PV string, and use a DC extension cable with an MC4 connector to connect the PV module or 3rd party optimizer adjacent to the possible faulty PV module. Set **DC SWITCH** to **ON**. If the inverter status is **Shutdown: Command**, choose **Maintenance > Inverter ON/OFF** on the home screen, and send a startup command. View alarm information.
- If no **Low insulation resistance** alarm is reported 1 minute after the DC side is powered on, the fault occurred on the disconnected PV module and 3rd party optimizer. Choose

Maintenance > Inverter ON/OFF, send a shutdown command, and set **DC SWITCH** to **OFF**. Go to [Step 7](#).

- If the **Low insulation resistance** alarm is reported 1 minute after the DC side is powered on, the fault did not occur on the disconnected PV module and 3rd party optimizer. Go to [Step 6](#).

Step 6 Log in to the app, choose **Maintenance > Inverter ON/OFF** on the home screen, and send a shutdown command. Set **DC SWITCH** to **OFF**, reconnect the disconnected PV module and 3rd party optimizer, and repeat [Step 5](#) to check the PV modules and 3rd party optimizers adjacent to the possible fault location.

Step 7 Determine the position of the ground insulation fault:

- Disconnect the possible faulty PV module from the 3rd party optimizer.
- Connect the possible faulty 3rd party optimizer to the PV string.
- Set **DC SWITCH** to **ON**. If the inverter status is **Shutdown: Command**, choose **Maintenance > Inverter ON/OFF**, and send a startup command. View alarm information.
 - If no **Low insulation resistance** alarm is reported 1 minute after the DC side is powered on, the fault is on the possible faulty PV module.
 - If the **Low insulation resistance** alarm is reported 1 minute after the DC side is powered on, the fault is on the possible faulty 3rd party optimizer.
- Log in to the app, choose **Maintenance > Inverter ON/OFF** on the home screen, and send a shutdown command. Set **DC SWITCH** to **OFF**, replace the faulty component, and complete troubleshooting the insulation resistance fault. Go to [Step 2](#) and check rest of the PV strings one by one. Then, go to [Step 8](#).

Step 8 Set **DC SWITCH** to **ON**. If the inverter status is **Shutdown: Command**, choose **Maintenance > Inverter ON/OFF**, and send a startup command.

 **NOTE**

Contact your dealer for list of compatible 3rd party Optimizers.

---End

G Acronyms and Abbreviations

A

AFCI arc-fault circuit interrupter

L

LED light emitting diode

M

MBUS monitoring bus

MPP maximum power point

MPPT maximum power point tracking

P

PE protective earthing

PID potential induced degradation

PV photovoltaic

R

RCD residual current device