



HYBRID 5000HC/8000/10000 1 Phase

User Manual

IS-HYB-10000-1PH

IS-HYB-10000-1PH-NZ

IS-HYB-5000HC-1PH

IS-HYB-8000-1PH

Issue 02
28/04/2026

About This Document

Purpose

This document describes the smart solar inverter in terms of the safety precautions, product introduction, installation, electrical connections, power-on and commissioning, maintenance, and technical specifications. Read this document carefully before installing and operating the inverter.






Intended Audience

This document is intended for:

- Installers
- Users

Symbol Conventions

The symbols that may be found in this document are defined as follows.

2	Description
 DANGER	Indicates a hazard with a high level of risk which, if not avoided, will result in death or serious injury.
 WARNING	Indicates a hazard with a medium level of risk which, if not avoided, could result in death or serious injury.
 CAUTION	Indicates a hazard with a low level of risk which, if not avoided, could result in minor or moderate injury.
 NOTICE	Indicates a potentially hazardous situation which, if not avoided, could result in equipment damage, data loss, performance deterioration, or unanticipated results. NOTICE is used to address practices not related to personal injury.
 NOTE	Supplements the important information in the main text. NOTE is used to address information not related to personal injury, equipment damage, and environment deterioration.

Change History

Changes between document issues are cumulative. The latest document issue contains all the changes made in earlier issues.

Issue 06 (2026-04-28)

- Updated sections 2.1/5.3/5.4/8.6

Issue 05 (2025-09-30)

- Updated [9 Technical Specifications](#).

Issue 04 (2025-05-30)

- Updated the product appearance.

Issue 03 (2025-03-31)

- Updated [5.2 Preparing Cables](#).
- Updated [9 Technical Specifications](#).

Issue 02 (2024-06-05)

- Updated [2.2 Appearance](#).
- Updated [4.6 Installing the Inverter on a Wall](#).
- Updated [4.7 Installing the Inverter on a Support](#).
- Updated [7.1 Powering On the Inverter](#).
- Updated [8.2 System Power-Off](#).

Issue 01 (2024-04-30)

This issue is the first official release.

Contents

About This Document	ii
I Safety Information	I
1.1 Personal Safety.....	1
1.2 Electrical Safety	3
1.3 Environment Requirements.....	5
1.4 Mechanical Safety.....	7
2 Overview	12
2.1 Networking	12
2.2 Appearance.	15
2.3 Working Modes	15
2.4 Label Description.....	17
2.5 Rapid Shutdown.....	18
3 Storage Requirements	20
4 Installation	21
4.1 Installation Modes	21
4.2 Installation Requirements.....	21
4.2.1 Site Selection Requirements.....	21
4.2.2 Clearance Requirements.....	22
4.2.3 Angle Requirements.....	24
4.3 Tools.....	24
4.4 Checking Before Installation	26
4.5 Moving the Inverter	27
4.6 Installing the Inverter on a Wall.....	27
4.7 Installing the Inverter on a Support.....	30
5 Electrical Connections	34
5.1 Precautions.....	34
5.2 Preparing Cables.....	35
5.3 Connecting a PE Cable	38
5.4 Connecting an AC Output Power Cable.....	40
5.5 Connecting DC Input Power Cables	44
5.6 (Optional) Connecting Battery Cables.....	48

5.7 Connecting Signal Cables	56
5.7.1 Connecting RS485 Communications Cables (Inverter Cascading).....	59
5.7.2 Connecting RS485 Communications Cables (Power Meter and Battery)	61
5.7.3 Connecting Rapid Shutdown Signal Cables.....	63
5.8 (Optional) Installing the Smart Dongle and Anti-theft Components	65
5.9 Installing an Antenna	65
6 Check Before Power-On	67
7 Power-On and Commissioning.....	68
7.1 Powering On the Inverter.....	68
7.2 Creating a Plant.....	70
7.2.1 Downloading the HiSolar App.....	70
7.2.2 Connecting to the Inverter.....	70
7.2.3 Quick Settings	71
7.2.4 What Should I Do If the Device Is Disconnected from the App When I Switch the Local Commissioning Screen to the Background?	72
7.3 Parameters Settings	72
7.3.1 Energy Control.....	73
7.3.1.1 Grid-tied Point Control	78
7.3.1.2 Apparent Power Control on the Inverter Output Side.....	79
7.3.1.3 Battery Control	79
7.3.1.4 Peak Shaving.....	81
7.3.2 AFCI.....	82
7.3.3 DRM	83
8 System Maintenance.....	86
8.1 Routine Maintenance.....	86
8.2 System Power-Off.....	88
8.3 Troubleshooting.....	88
8.4 Replacing an Inverter.....	100
8.5 Replacing a Fan.....	100
8.6 Locating Insulation Resistance Faults.....	101
9 Technical Specifications	105
A Grid Codes.....	110
B Baud Rate Negotiation	112
C Resetting Password	115
D Acronyms and Abbreviations.	116

Safety Information

I.1 Personal Safety

 **DANGER**

Ensure that power is off during installation. Do not install or remove a cable with power on. Transient contact between the core of the cable and the conductor will generate electric arcs or sparks, which may cause a fire or personal injury.

 **DANGER**

Non-standard and improper operations on the energized equipment may cause fire, electric shocks, or explosion, resulting in property damage, personal injury, or even death.

 **DANGER**

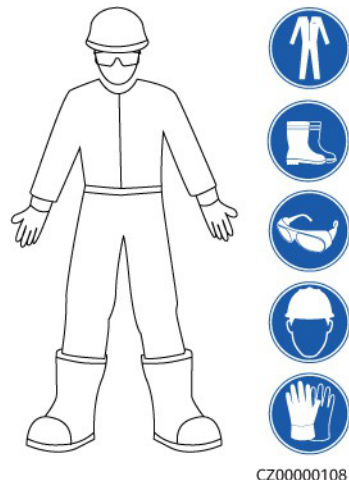
Before operations, remove conductive objects such as watches, bracelets, bangles, rings, and necklaces to prevent electric shocks.

 **DANGER**

During operations, use dedicated insulated tools to prevent electric shocks or short circuits. The dielectric withstanding voltage level must comply with local laws, regulations, standards, and specifications.

 **WARNING**

During operations, wear personal protective equipment such as protective clothing, insulated shoes, goggles, safety helmets, and insulated gloves.

Figure I-I Personal protective equipment

General Requirements

- Do not stop protective devices. Pay attention to the warnings, cautions, and related precautionary measures in this document and on the equipment.
- If there is a likelihood of personal injury or equipment damage during operations, immediately stop, report the case to the supervisor, and take feasible protective measures.
- Do not power on the equipment before it is installed or confirmed by professionals.
- Do not touch the power supply equipment directly or with conductors such as damp objects. Before touching any conductor surface or terminal, measure the voltage at the contact point to ensure that there is no risk of electric shock.
- Do not touch operating equipment because the enclosure is hot.
- Do not touch a running fan with your hands, components, screws, tools, or boards. Otherwise, personal injury or equipment damage may occur.
- In the case of a fire, immediately leave the building or the equipment area and activate the fire alarm or call emergency services. Do not enter the affected building or equipment area under any circumstances.

Personnel Requirements

- Only professionals and trained personnel are allowed to operate the equipment.
 - Professionals: personnel who are familiar with the working principles and structure of the equipment, trained or experienced in equipment operations and are clear of the sources and degree of various potential hazards in equipment installation, operation, maintenance
 - Trained personnel: personnel who are trained in technology and safety, have required experience, are aware of possible hazards on themselves in certain operations, and are able to take protective measures to minimize the hazards on themselves and other people
- Personnel who plan to install or maintain the equipment must receive adequate training, be able to correctly perform all operations, and understand all necessary safety precautions and local relevant standards.

- Only qualified professionals or trained personnel are allowed to install, operate, and maintain the equipment.
- Only qualified professionals are allowed to remove safety facilities and inspect the equipment.
- Personnel who will perform special tasks such as electrical operations, working at heights, and operations of special equipment must possess the required local qualifications.
- Only authorized professionals are allowed to replace the equipment or components (including software).
- Only personnel who need to work on the equipment are allowed to access the equipment.

I.2 Electrical Safety

 DANGER

Before connecting cables, ensure that the equipment is intact. Otherwise, electric shocks or fire may occur.

 DANGER

Non-standard and improper operations may result in fire or electric shocks.

 DANGER

Prevent foreign matter from entering the equipment during operations. Otherwise, equipment short-circuits or damage, load power derating, power failure, or personal injury may occur.

 WARNING

For the equipment that needs to be grounded, install the ground cable first when installing the equipment and remove the ground cable last when removing the equipment.

 WARNING

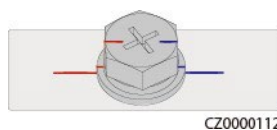
During the installation of PV strings and the inverter, the positive or negative terminals of PV strings may be short-circuited to ground if the power cables are not properly installed or routed. In this case, an AC or DC short circuit may occur and damage the inverter. The resulting device damage is not covered under any warranty.

 **CAUTION**

Do not route cables near the air intake or exhaust vents of the equipment.

General Requirements

- Follow the procedures described in the document for installation, operation, and maintenance. Do not reconstruct or alter the equipment, add components, or change the installation sequence without permission.
- Obtain approval from the national or local electric utility company before connecting the equipment to the grid.
- Observe the power plant safety regulations, such as the operation and work ticket mechanisms.
- Install temporary fences or warning ropes and hang "No Entry" signs around the operation area to keep unauthorized personnel away from the area.
- Before installing or removing power cables, turn off the switches of the equipment and its upstream and downstream switches.
- Before performing operations on the equipment, check that all tools meet the requirements and record the tools. After the operations are complete, collect all of the tools to prevent them from being left inside the equipment.
- Before installing power cables, check that cable labels are correct and cable terminals are insulated.
- When installing the equipment, use a torque tool of a proper measurement range to tighten the screws. When using a wrench to tighten the screws, ensure that the wrench does not tilt and the torque error does not exceed 10% of the specified value.
- Ensure that bolts are tightened with a torque tool and marked in red and blue after double-check. Installation personnel mark tightened bolts in blue. Quality inspection personnel confirm that the bolts are tightened and then mark them in red. (The marks must cross the edges of the bolts.)



- If the equipment has multiple inputs, disconnect all the inputs and wait until the equipment is completely powered off before performing operations on the equipment.
- Before maintaining a downstream electrical or power distribution device, turn off the output switch on the power supply equipment.
- During equipment maintenance, attach "Do not switch on" labels near the upstream and downstream switches or circuit breakers as well as warning signs to prevent accidental connection. The equipment can be powered on only after troubleshooting is complete.
- Do not open equipment panels.
- Check equipment connections periodically, ensuring that all screws are securely tightened.
- Only qualified professionals can replace a damaged cable.

- Do not scrawl, damage, or block any labels or nameplates on the equipment. Promptly replace labels that have worn out.
- Do not use solvents such as water, alcohol, or oil to clean electrical components inside or outside of the equipment.

Grounding

- Ensure that the grounding impedance of the equipment complies with local electrical standards.
- Ensure that the equipment is connected permanently to the protective ground. Before operating the equipment, check its electrical connection to ensure that it is reliably grounded.
- Do not work on the equipment in the absence of a properly installed ground conductor.
- Do not damage the ground conductor.

Cabling Requirements

- When selecting, installing, and routing cables, follow local safety regulations and rules.
- When routing power cables, ensure that there is no coiling or twisting. Do not join or weld power cables. If necessary, use a longer cable.
- Ensure that all cables are properly connected and insulated, and meet specifications.
- Ensure that the slots and holes for routing cables are free from sharp edges, and that the positions where cables are routed through pipes or cable holes are equipped with cushion materials to prevent the cables from being damaged by sharp edges or burrs.
- Ensure that cables of the same type are bound together neatly and straight and that the cable sheath is intact. When routing cables of different types, ensure that they are away from each other without entanglement and overlapping.
- Secure buried cables using cable supports and cable clips. Ensure that the cables in the backfill area are in close contact with the ground to prevent cable deformation or damage during backfilling.
- If the external conditions (such as the cable layout or ambient temperature) change, verify the cable usage in accordance with the IEC-60364-5-52 or local laws and regulations. For example, check that the current-carrying capacity meets requirements.
- When routing cables, reserve at least 30 mm clearance between the cables and heat-generating components or areas. This prevents deterioration or damage to the cable insulation layer.

I.3 Environment Requirements



Do not expose the equipment to flammable or explosive gas or smoke. Do not perform any operation on the equipment in such environments.

 DANGER

Do not store any flammable or explosive materials in the equipment area.

 DANGER

Do not place the equipment near heat sources or fire sources, such as smoke, candles, heaters, or other heating devices. Overheat may damage the equipment or cause a fire.

 WARNING

Install the equipment in an area far away from liquids. Do not install it under areas prone to condensation, such as under water pipes and air exhaust vents, or areas prone to water leakage, such as air conditioner vents, ventilation vents, or feeder windows of the equipment room. Ensure that no liquid enters the equipment to prevent faults or short circuits.

 WARNING

To prevent damage or fire due to high temperature, ensure that the ventilation vents or heat dissipation systems are not obstructed or covered by other objects while the equipment is running.

General Requirements

- Store the equipment according to the storage requirements. Equipment damage caused by unqualified storage conditions is not covered under the warranty.
- Keep the installation and operating environments of the equipment within the allowed ranges. Otherwise, its performance and safety will be compromised.
- The operating temperature range provided in the equipment's technical specifications refers to the ambient temperatures in equipment's installation environment.
- Do not install, use, or operate outdoor equipment and cables (including but not limited to moving equipment, operating equipment and cables, inserting connectors to or removing connectors from signal ports connected to outdoor facilities, working at heights, performing outdoor installation, and opening doors) in harsh weather conditions such as lightning, rain, snow, and level 6 or stronger wind.
- Do not install the equipment in an environment with dust, smoke, volatile or corrosive gases, infrared and other radiations, organic solvents, or salty air.
- Do not install the equipment in an environment with conductive metal or magnetic dust.
- Do not install the equipment in an area conducive to the growth of microorganisms such as fungus or mildew.

- Do not install the equipment in an area with strong vibration, noise, or electromagnetic interference.
- Ensure that the site complies with local laws, regulations, and related standards.
- Ensure that the ground in the installation environment is solid, free from spongy or soft soil, and not prone to subsidence. The site must not be located in a low-lying land prone to water or snow accumulation, and the horizontal level of the site must be above the highest water level of that area in history.
- Do not install the equipment in a position that may be submerged in water.
- If the equipment is installed in a place with abundant vegetation, in addition to routine weeding, harden the ground underneath the equipment using cement or gravel (the area shall be greater than or equal to 3 m x 2.5 m).
- Do not install the equipment outdoors in salt-affected areas because it may be corroded. A salt-affected area refers to the region within 500 m of the coast or prone to sea breeze. Regions prone to sea breeze vary with weather conditions (such as typhoons and monsoons) or terrains (such as dams and hills).
- Before installation, operation, and maintenance, clean up any water, ice, snow, or other foreign objects on the top of the equipment.
- When installing the equipment, ensure that the installation surface is solid enough to bear the weight of the equipment.
- After installing the equipment, remove the packing materials such as cartons, foam, plastics, and cable ties from the equipment area.

I.4 Mechanical Safety

 WARNING

Ensure that all necessary tools are ready and inspected by a professional organization. Do not use tools that have signs of scratches or fail to pass the inspection or whose inspection validity period has expired. Ensure that the tools are secure and not overloaded.

 WARNING

Do not drill holes into the equipment. Doing so may affect the sealing performance and electromagnetic containment of the equipment and damage components or cables inside. Metal shavings from drilling may short-circuit boards inside the equipment.

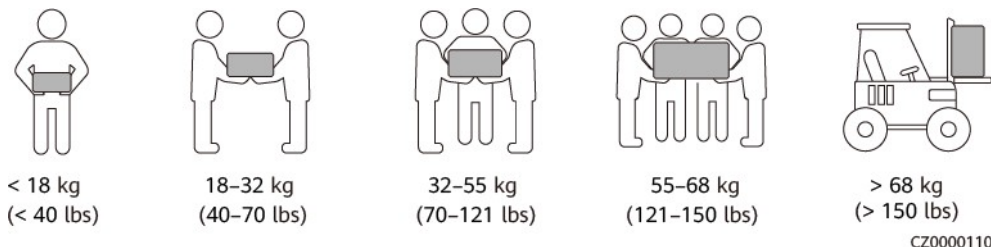
General Requirements

- Repaint any paint scratches caused during equipment transportation or installation in a timely manner. Equipment with scratches must not be exposed for an extended period of time.

- Do not perform operations such as arc welding and cutting on the equipment without evaluation by the Company.
- Do not install other devices on the top of the equipment without evaluation by the Company.
- When performing operations over the top of the equipment, take measures to protect the equipment against damage.
- Use correct tools and operate them in the correct way.

Moving Heavy Objects

- Be cautious to prevent injury when moving heavy objects.



- If multiple persons need to move a heavy object together, determine the manpower and work division with consideration of height and other conditions to ensure that the weight is equally distributed.
- If two persons or more move a heavy object together, ensure that the object is lifted and landed simultaneously and moved at a uniform pace under the supervision of one person.
- Wear personal protective gears such as protective gloves and shoes when manually moving the equipment.
- To move an object by hand, approach to the object, squat down, and then lift the object gently and stably by the force of the legs instead of your back. Do not lift it suddenly or turn your body around.
- Do not quickly lift a heavy object above your waist. Place the object on a workbench that is half-waist high or any other appropriate place, adjust the positions of your palms, and then lift it.
- Move a heavy object stably with balanced force at an even and low speed. Put down the object stably and slowly to prevent any collision or drop from scratching the surface of the equipment or damaging the components and cables.
- When moving a heavy object, be aware of the workbench, slope, staircase, and slippery places. When moving a heavy object through a door, ensure that the door is wide enough to move the object and avoid bumping or injury.
- When transferring a heavy object, move your feet instead of turning your waist around. When lifting and transferring a heavy object, ensure that your feet point to the target direction of movement.
- When transporting the equipment using a pallet truck or forklift, ensure that the tynes are properly positioned so that the equipment does not topple. Before moving the equipment, secure it to the pallet truck or forklift using ropes. When moving the equipment, assign dedicated personnel to take care of it.
- Choose sea, roads in good conditions, or airplanes for transportation. Do not transport the equipment by railway. Avoid tilt or jolt during transportation.

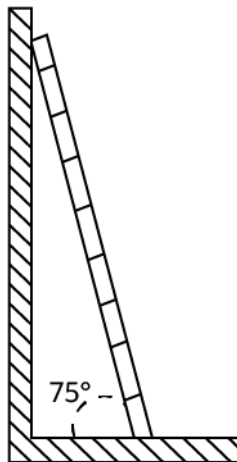
Using Ladders

- Use wooden or insulated ladders when you need to perform live-line working at heights.
- Platform ladders with protective rails are preferred. Single ladders are not recommended.
- Before using a ladder, check that it is intact and confirm its load bearing capacity. Do not overload it.
- Ensure that the ladder is securely positioned and held firm.



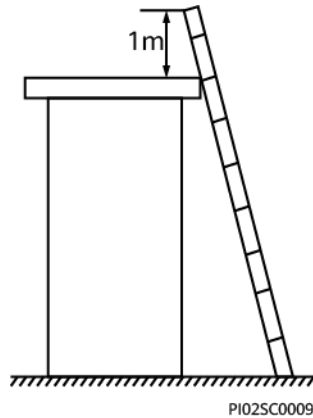
CZ00000107

- When climbing up the ladder, keep your body stable and your center of gravity between the side rails, and do not overreach to the sides.
- When a step ladder is used, ensure that the pull ropes are secured.
- If a single ladder is used, the recommended angle for the ladder against the floor is 75 degrees, as shown in the following figure. A square can be used to measure the angle.



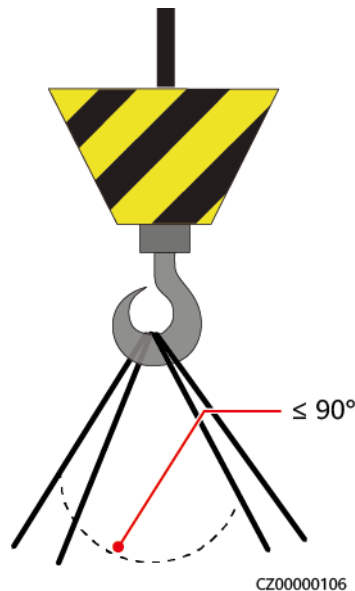
P1025C0008

- If a single ladder is used, ensure that the wider end of the ladder is at the bottom, and take protective measures to prevent the ladder from sliding.
- If a single ladder is used, do not climb higher than the fourth rung of the ladder from the top.
- If you use a single ladder to climb up to a platform, ensure that the ladder is at least 1 m higher than the platform.



Hoisting

- Only trained and qualified personnel are allowed to perform hoisting operations.
- Install temporary warning signs or fences to isolate the hoisting area.
- Ensure that the foundation where hoisting is performed on meets the load-bearing requirements.
- Before hoisting objects, ensure that hoisting tools are firmly secured onto a fixed object or wall that meets the load-bearing requirements.
- During hoisting, do not stand or walk under the crane or the hoisted objects.
- Do not drag steel ropes and hoisting tools or bump the hoisted objects against hard objects during hoisting.
- Ensure that the angle between two hoisting ropes is no more than 90 degrees, as shown in the following figure.



Drilling Holes

- Obtain consent from the customer and contractor before drilling holes.
- Wear protective equipment such as safety goggles and protective gloves when drilling holes.

- To avoid short circuits or other risks, do not drill holes into buried pipes or cables.
- When drilling holes, protect the equipment from shavings. After drilling, clean up any shavings.

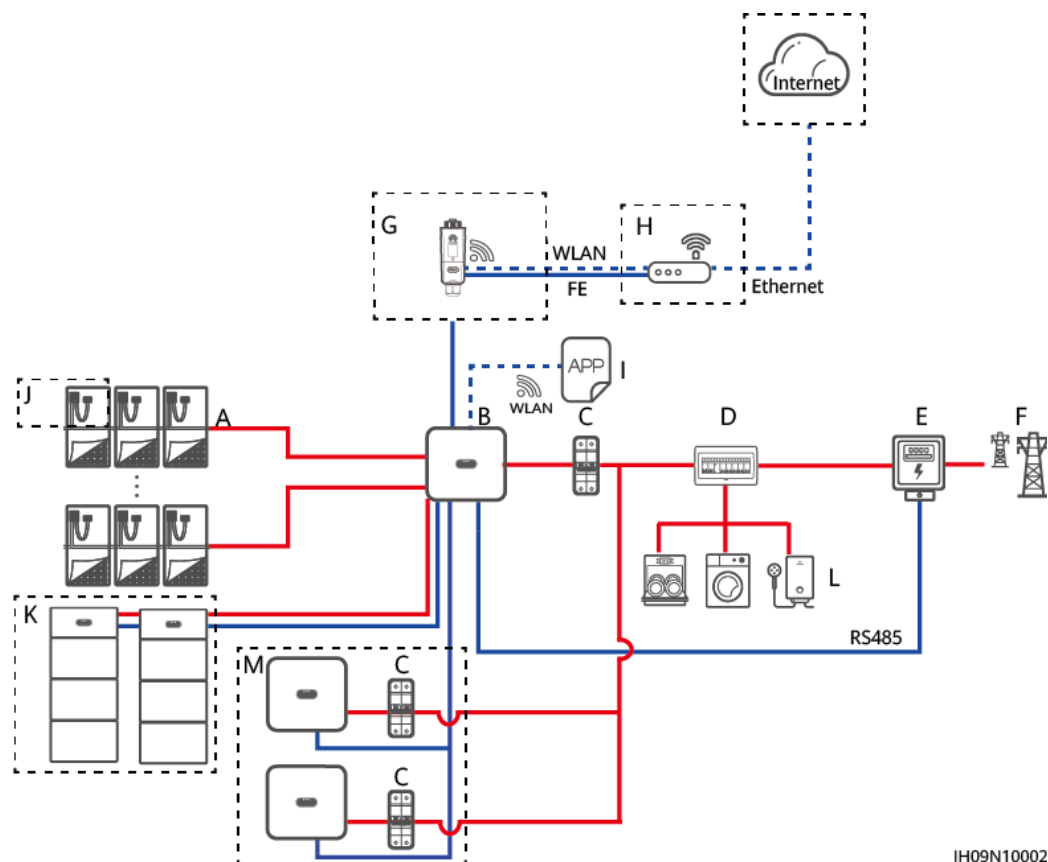
2 Overview

2.1 Networking

The inverter applies to residential rooftop grid-tied systems and small-sized ground grid-tied PV plants. The system consists of PV strings, grid-tied inverters, AC switches, and power distribution units (PDUs).

Smart Dongle Networking




Figure 2-I Smart Dongle networking (the components in dashed boxes are optional)



IH09N10002

(A) PV strings	(B) Master inverter	(C) AC switches or RCDs
(D) AC PDU	(E) Power meter	(F) Power grid
(G) WLAN-FE Smart Dongle	(H) Router	(I) HiSolar app
(J) Optimizer	(K) Battery	(L) Load
(M) Slave inverter		

NOTE

-  indicates a power cable,  indicates a signal cable, and  indicates wireless communication.
- In the inverter cascading scenario, a maximum of three inverters can be cascaded, and each inverter can connect to a maximum of two batteries.
- In the inverter cascading scenario, only one power meter can be connected to the master inverter.
- In the inverter cascading scenario, the inverters connected to the power grid must meet the local power grid requirements.
- Where iStore inverters are not certified to Section 5 AS/NZS 4777.2:2020, multiple inverter or multi-phase configurations shall only be used where external devices, including an iStore WLAN Smart Dongle and iStore single phase or three phase energy meter, are installed to provide centralized control in accordance with AS/NZS 4777.1.

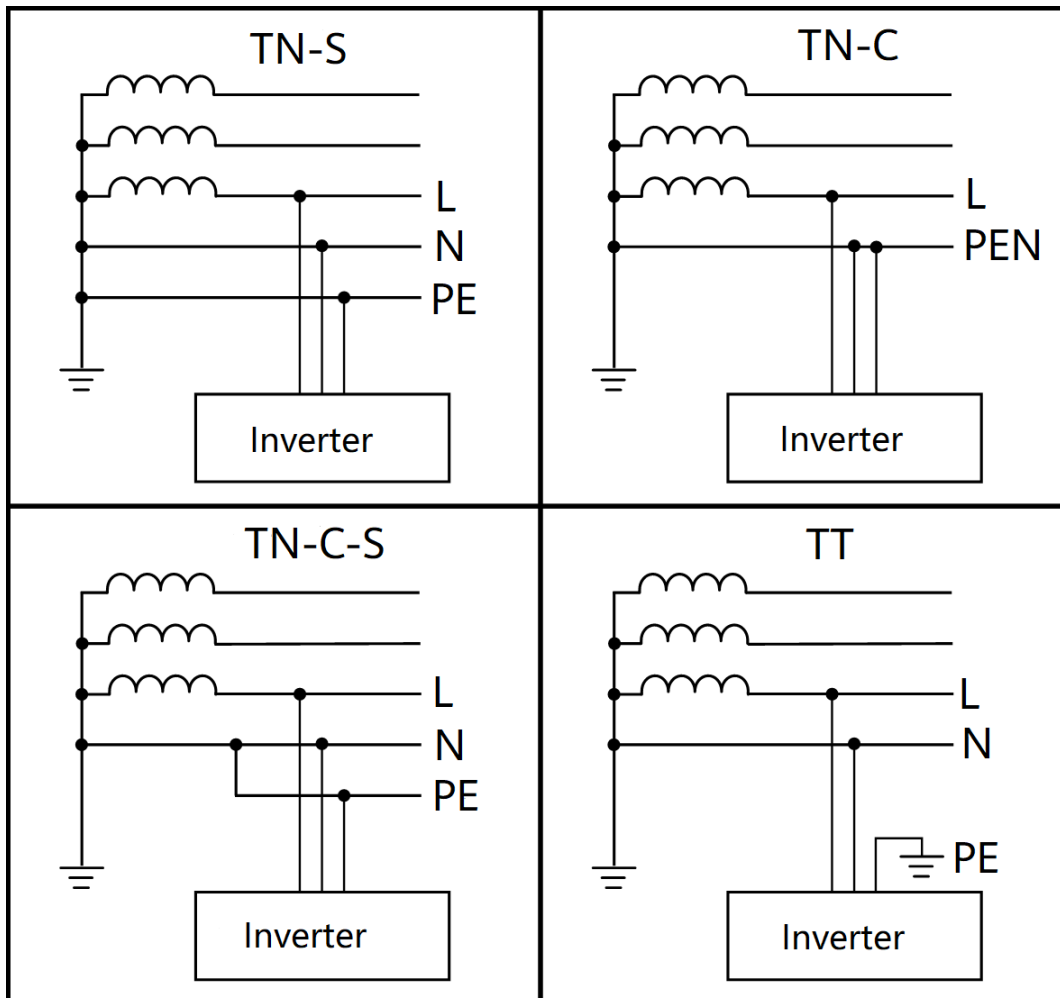
NOTE

The MPPT voltage must be greater than the lower threshold of the full-load MPPT range specified in [9 Technical Specifications](#). Otherwise, the inverter will be derated, causing the system yield loss

Supported Power Grid Types

The inverter supports the following power grid types: TN-S, TN-C, TN-C-S, and TT. In the TT power grid, the N-to-PE voltage must be less than 30 V.

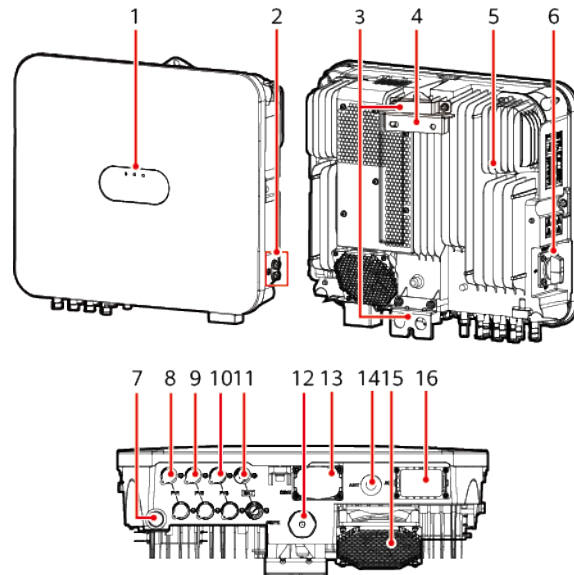
Figure 2-2 Power grid types



2.2 Appearance

Appearance and Ports

Figure 2-3 Appearance



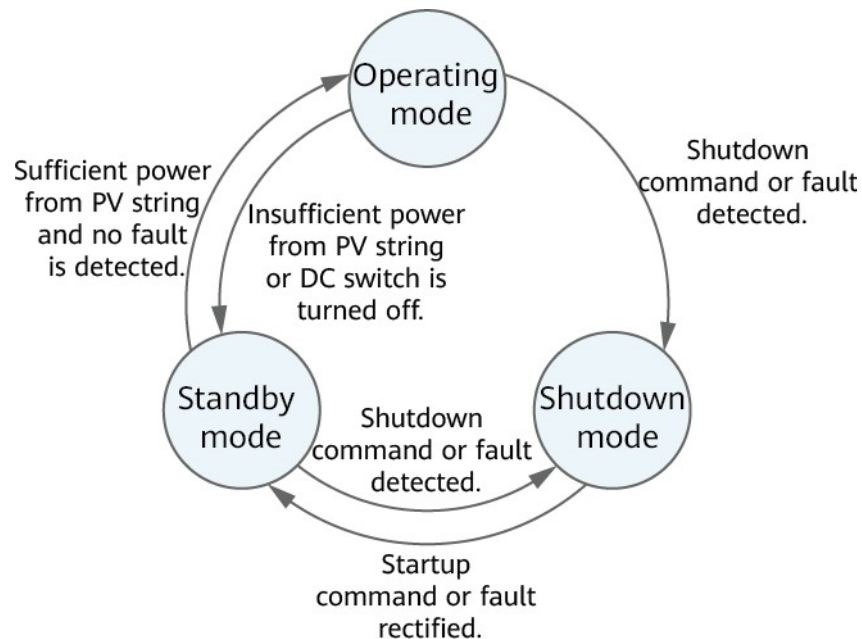
IH09W00001

- | | |
|-----------------------------------|------------------------------------|
| (1) LED indicators | (2) Ground screws |
| (3) Hanging kits | (4) Mounting bracket |
| (5) Heat sink | (6) DC switch (DC SWITCH) |
| (7) Ventilation valve | (8) DC input terminal (PV1+/PV1-) |
| (9) DC input terminal (PV2+/PV2-) | (10) DC input terminal (PV3+/PV3-) |
| (11) Battery terminal (BAT+/BAT-) | (12) Smart Dongle port (FE) |
| (13) Communications port (COM) | (14) Antenna port (ANT) |
| (15) Fan ^[1] | (16) AC output port (AC) |

Note [1]: Only the 9.999K inverter are equipped with fans.

2.3 Working Modes

The inverter can work in Standby, Operating, or Shutdown mode.

Figure 2-4 Working modes







IS07500001




Table 2-1 Working mode description

Working Mode	Description
Standby	<p>The inverter enters Standby mode when the external environment does not meet the operating requirements. In Standby mode:</p> <ul style="list-style-type: none"> • The inverter continuously performs status check and enters the Operating mode once the operating requirements are met. • The inverter enters Shutdown mode after detecting a shutdown command or a fault after startup.
Operating	<p>In Operating mode:</p> <ul style="list-style-type: none"> • The inverter converts DC power from PV strings into AC power and feeds the power to the power grid. • The inverter tracks the maximum power point to maximize the PV string output. • If the inverter detects a fault or a shutdown command, it enters the Shutdown mode. • The inverter enters Standby mode after detecting that the PV string output power is not suitable for connecting to the power grid for generating power.
Shutdown	<ul style="list-style-type: none"> • In Standby or Operating mode, the inverter enters Shutdown mode after detecting a fault or shutdown command. • In Shutdown mode, the inverter enters Standby mode after detecting a startup command or that the fault is rectified.

2.4 Label Description

Enclosure Labels

Label	Symbol	Name	Meaning
	 	Delayed discharge	Residual voltage exists after the inverter is powered off. It takes 5 minutes for the inverter to discharge to the safe voltage level before maintenance.
		Burn warning	Do not touch the inverter when it is running because its enclosure is hot.
		Electric shock warning	<ul style="list-style-type: none"> High voltage exists after the inverter is powered on. Only qualified and trained electrical technicians are allowed to perform operations on the inverter. High touch current exists after the inverter is powered on. Before powering on the inverter, ensure that the inverter is properly grounded.
		Refer to documentation	Reminds operators to refer to the documents delivered the inverter.

Label	Symbol	Name	Meaning
		Operation warning	Do not remove the DC input connector or AC output connector when the inverter is running.
 (1P)PN/ITEM:XXXXXXXX Y (32P)Model: XXXXXXXX (S)SN:XXXXXXXXXXXXX MADE IN CHINA	-	Serial number (SN)	Indicates the product SN.
	-	QR code for inverter WiFi connection	Scan the QR code to connect to the inverter WiFi.

Product Nameplate

The nameplate contains the trademark, product model, important technical specifications, compliance symbols, company name, and place of origin.

2.5 Rapid Shutdown

If optimizers are configured for all PV modules, the PV system can perform a rapid shutdown to decrease the output voltage to below 30 V within 30s.

NOTE

- If method 3 is selected for rapid shutdown, log in to the HiSolar app as an **installer** user to perform local commissioning, choose **Settings > Feature parameters > Dry contact function**, and set **Dry contact function** to **DI rapid shutdown**.

Perform the following steps to trigger a rapid shutdown:

- Method 1: Turn off the AC switch between the inverter and the power grid (disconnect the voltages of all PV strings connected to the inverter under the AC switch).
- Method 2: Set the **DC SWITCH** of the inverter to **OFF** to trigger a rapid shutdown. (Turning off all external switches on the DC side of an inverter can trigger a rapid shutdown, and only the PV strings connected to the inverter are de-energized. Turning off only some external switches cannot trigger a rapid shutdown, and the PV strings may be energized.)
- Method 3: To enable the DI rapid shutdown function, connect a switch to pins DI and GND of the inverter communications terminal. The switch is turned on by default. Turn off the switch to trigger a rapid shutdown. The distance between the switch and the farthest inverter must be less than or equal to 10 m.

- Method 4: If **AFCI** is enabled, the inverter automatically performs arc fault detection and triggers a rapid shutdown when AFCI lock protection is implemented.

3 Storage Requirements

The following requirements shall be met if inverters are not put into use immediately:

- Do not unpack inverters.
- Keep the storage temperature at -40°C to $+70^{\circ}\text{C}$ and the humidity at 5%-95% RH.
- Store inverters in a clean and dry place and protect them from dust and moisture.
- Inverters can be stacked in a maximum of eight layers. To avoid personal injury or device damage, stack inverters with caution to prevent them from falling over.
- During the storage period, check inverters periodically (recommended: once every three months). Replace the packing materials that are damaged by insects or rodents in a timely manner.
- If inverters have been stored for two years or longer, they must be checked and tested by professionals before being put into use.

4 Installation

4.1 Installation Modes

The inverter can be wall-mounted or support-mounted.

Table 4-1 Installation modes

Installation Mode	Screw Specifications	Description
Wall mounting	M6x60 stainless steel expansion bolt	Delivered with the product
Support mounting	M6 bolt assembly	Prepared by the customer

4.2 Installation Requirements

4.2.1 Site Selection Requirements

Basic Requirements

- The inverter is protected to IP66 and can be installed indoors or outdoors.
- Do not install the inverter in a place where personnel are easy to come into contact with its enclosure and heat sink, because these parts are hot during operation.
- Do not install the inverter in noise-sensitive areas.
- Do not install the inverter near flammable or explosive materials.
- Keep the inverter out of reach of children.
- The inverter will be corroded in salt areas, and the salt corrosion may cause fire. Do not install the inverter outdoors in salt areas. A salt-affected area refers to the region within 500 m of the coast or prone to sea breeze. Regions prone to sea breeze vary with weather conditions (such as typhoons and monsoons) or terrains (such as dams and hills).

- Install the inverter in a well-ventilated environment to ensure good heat dissipation.
- You are advised to install the inverter in a sheltered area or install an awning over it.

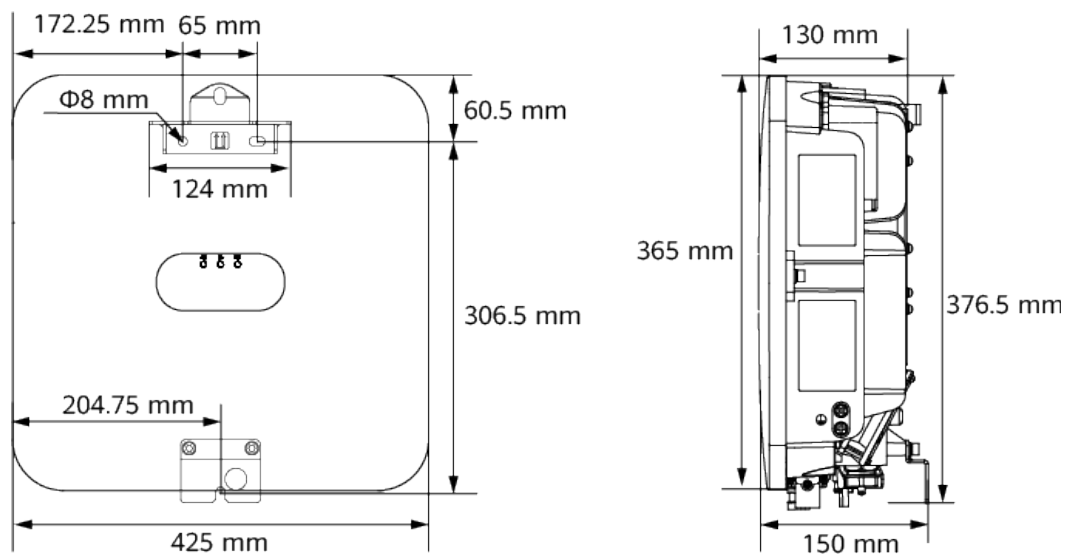
Mounting Structure Requirements

- The mounting structure where the inverter is installed must be fire resistant.
- Do not install the inverter on flammable building materials.
- The inverter is heavy. Ensure that the installation surface is solid enough to bear the weight.
- In residential areas, do not install the inverter on a drywall or wall made of similar materials which have a weak sound insulation performance because the inverter generates noise during operation.

4.2.2 Clearance Requirements

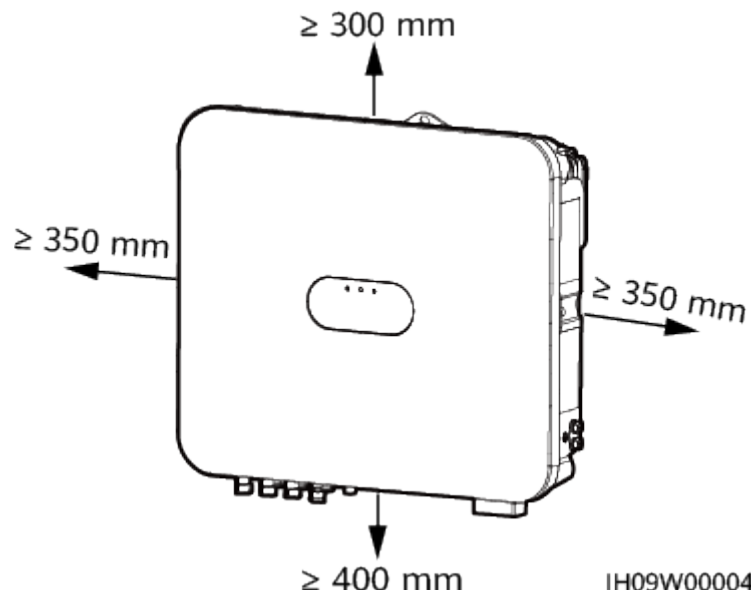
Figure 4-I shows the dimensions of mounting holes for the inverter.

Figure 4-I Mounting bracket dimensions

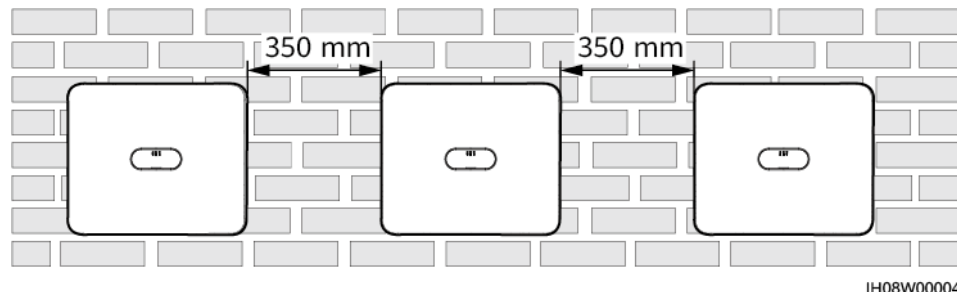
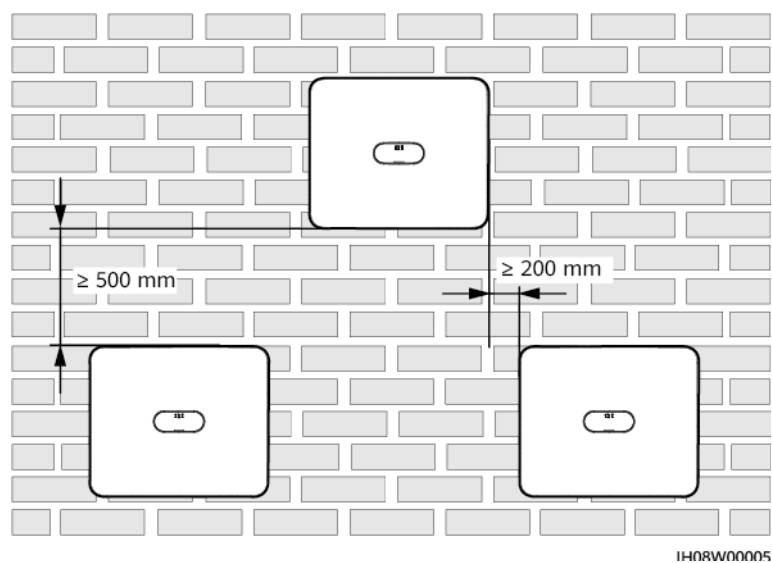


IH09W00003

- Reserve enough clearances around the inverter to ensure sufficient space for installation and heat dissipation.

Figure 4-2 Clearances

- When installing multiple inverters, install them in horizontal mode if sufficient space is available and install them in triangle mode if no sufficient space is available. Stacked installation is not recommended.

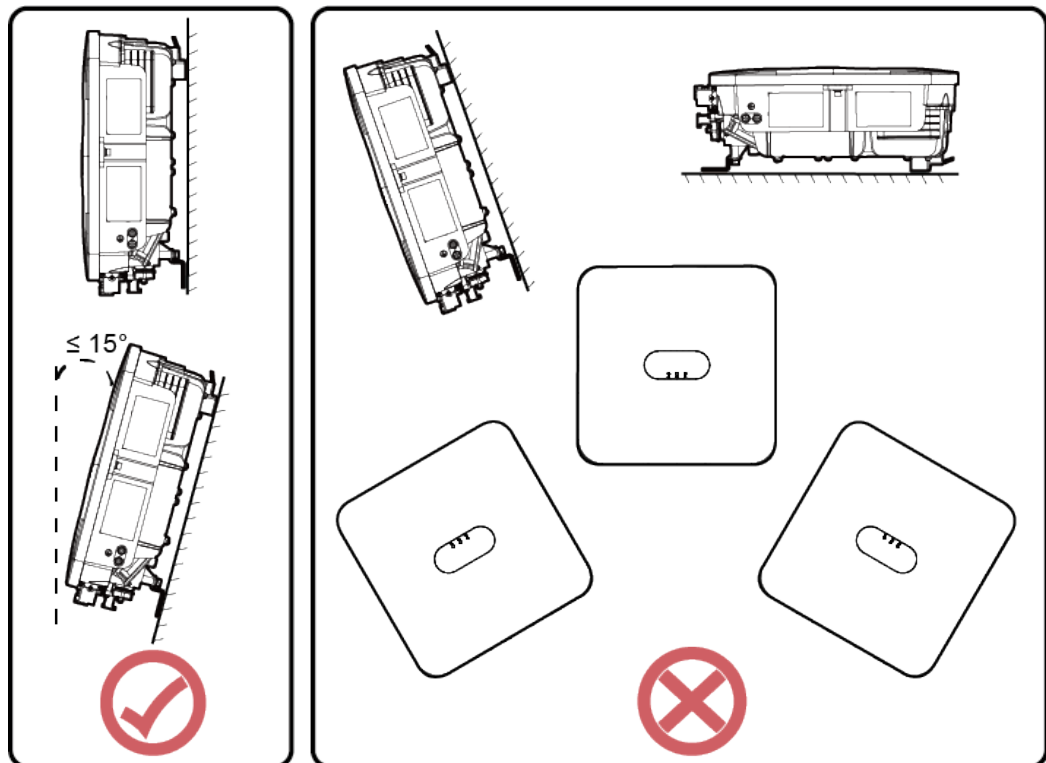
Figure 4-3 Horizontal installation mode (recommended)**Figure 4-4 Triangle installation mode (recommended)**

4.2.3 Angle Requirements

The inverter can be wall-mounted or support-mounted. The installation angle requirements are as follows:

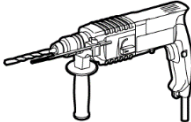






- Install the inverter vertically or at a maximum back tilt of 15 degrees to facilitate heat dissipation.
- Do not install the inverter at forward tilted, excessive backward tilted, side tilted, horizontal, or upside down positions.


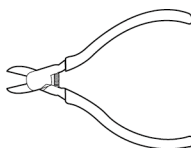
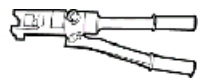
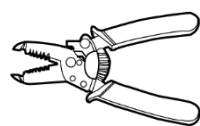

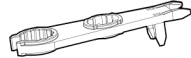

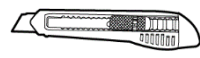

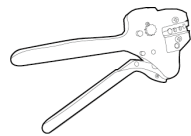


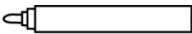
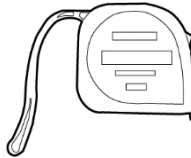


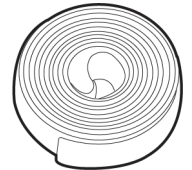
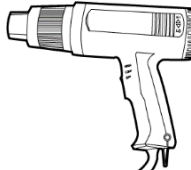
Figure 4-5 Installation angle





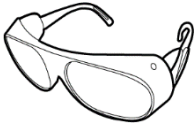


IH09W00005

4.3 Tools

Type	Tool			
Installation tools	 Hammer drill Drill bit: $\Phi 8$ mm, $\Phi 6$ mm	  Flat-head insulated torque screwdriver	  Phillips insulated torque screwdriver	  Hex insulated torque screwdriver

Type	Tool			
	 Insulated torque socket wrench	 Diagonal pliers	 Hydraulic pliers	 Wire stripper
	 Cable tie	 Removal wrench Model: H4TW0001	 Rubber mallet	 Utility knife
	 Cable cutter	 Crimping tool Model: H4TC0003	 Multimeter DC voltage measurement range ≥ 1100 V DC	 Vacuum cleaner
	 Marker	 Steel measuring tape	 Digital or bubble level	 Cord end terminal crimping tool
	 Heat shrink tubing	 Heat gun	-	-

Type	Tool			
Personal protective equipment (PPE)				
	Insulated gloves	Protective gloves	Dust mask	Safety shoes
		-	-	-
	Safety goggles			

4.4 Checking Before Installation

Outer Packing Materials

Before unpacking the inverter, check the outer packing materials for damage, such as holes and cracks, and check the inverter model. If any damage is found or the inverter model is not what you requested, do not unpack the package and contact your supplier as soon as possible.

NOTE

You are advised to remove the packing materials within 24 hours before installing the inverter.

Package Contents

NOTICE

- After placing the equipment in the installation position, unpack it with care to prevent scratches. Keep the equipment stable during unpacking.

After unpacking the inverter, check that the contents are intact and complete. If any damage is found or any component is missing, contact your supplier.

NOTE

For details about the number of contents, see the *Packing List* in the packing case.

4.5 Moving the Inverter

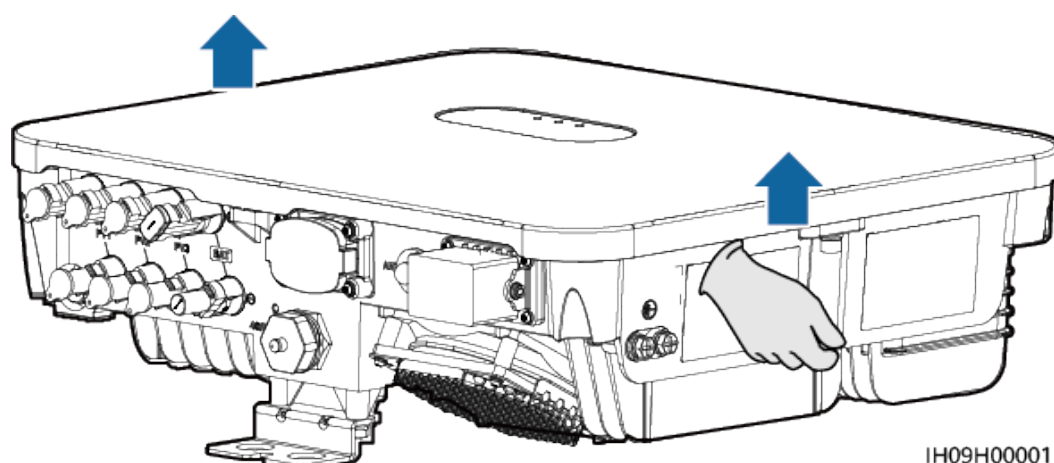
Procedure

- Step 1** Hold the handles on both sides of the inverter, lift the inverter from the packing case, and transport it to the installation position.

CAUTION

- Move the inverter with care to prevent device damage and personal injury.
 - Do not use the wiring terminals and ports at the bottom to support any weight of the inverter.
 - When you need to temporarily place the inverter on the ground, use foam, cardboard, or other protection material to prevent damage to its enclosure.
-

Figure 4-6 Moving the inverter



----End

4.6 Installing the Inverter on a Wall

Procedure

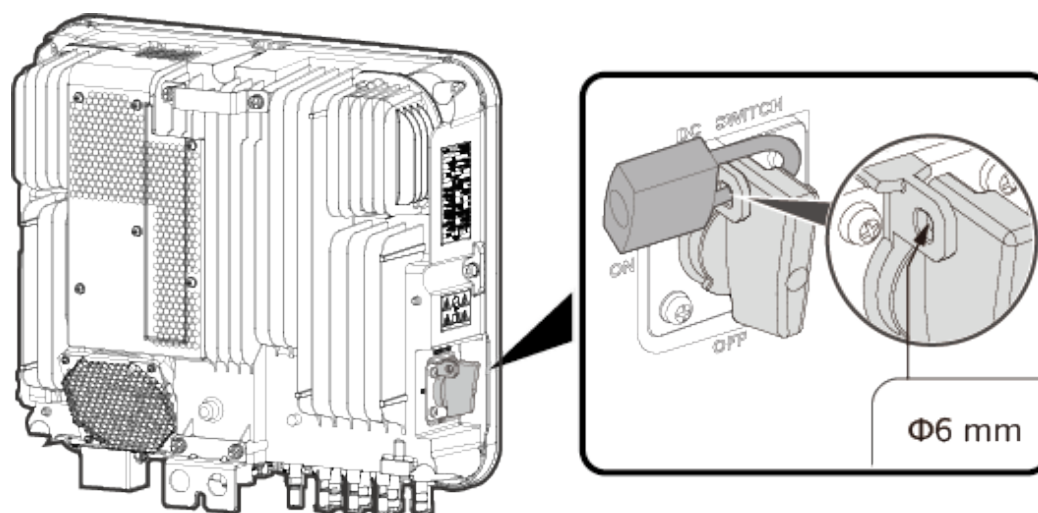
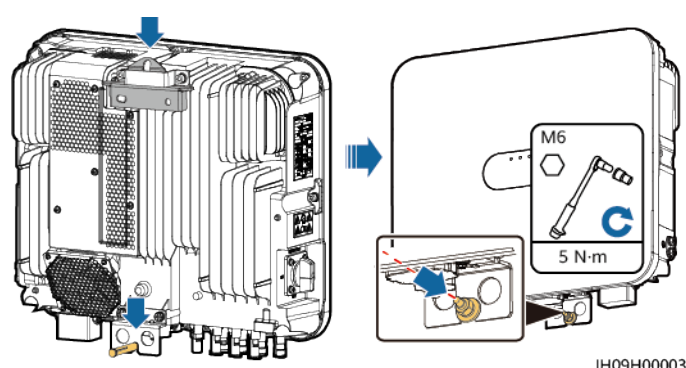
- Step 1** Determine the positions for drilling holes using the marking-off template, level the holes using a level, and mark the positions using a marker.
- Step 2** Secure the mounting bracket.

DANGER

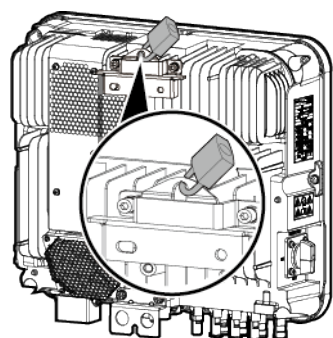
Avoid drilling holes into the water pipes or power cables buried in the wall.

Step 3 Install the DC switch padlock.**NOTE**

For models used in Australia, the DC switch padlock needs to be installed according to the local standard to secure the DC switch (DC SWITCH) and prevent incorrect startup. The DC switch padlock needs to be prepared by the customer.

Figure 4-9 Installing the DC switch padlock**Step 4** Install the inverter on the mounting bracket.**Step 5** Tighten the nuts.**Figure 4-10** Tightening nuts**Step 6** (Optional) Install an anti-theft lock.**NOTICE**

- Prepare an anti-theft lock suitable for the lock hole diameter ($\Phi 10$ mm).
- An outdoor waterproof lock is recommended.
- Keep the key to the anti-theft lock.

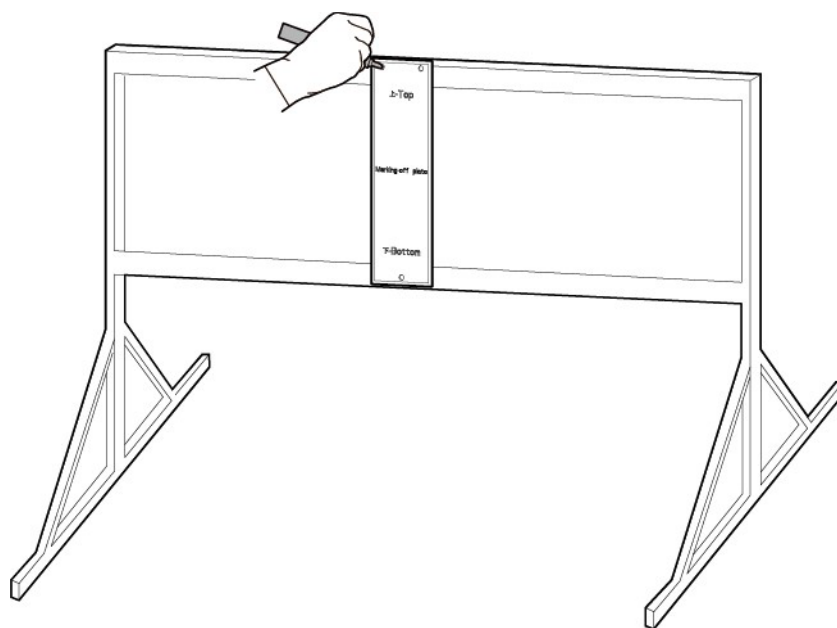
Figure 4-11 Installing an anti-theft lock

IH09H00005

----End

4.7 Installing the Inverter on a Support

Step 1 Determine the positions for drilling holes using the marking-off template, and then mark the positions with a marker.

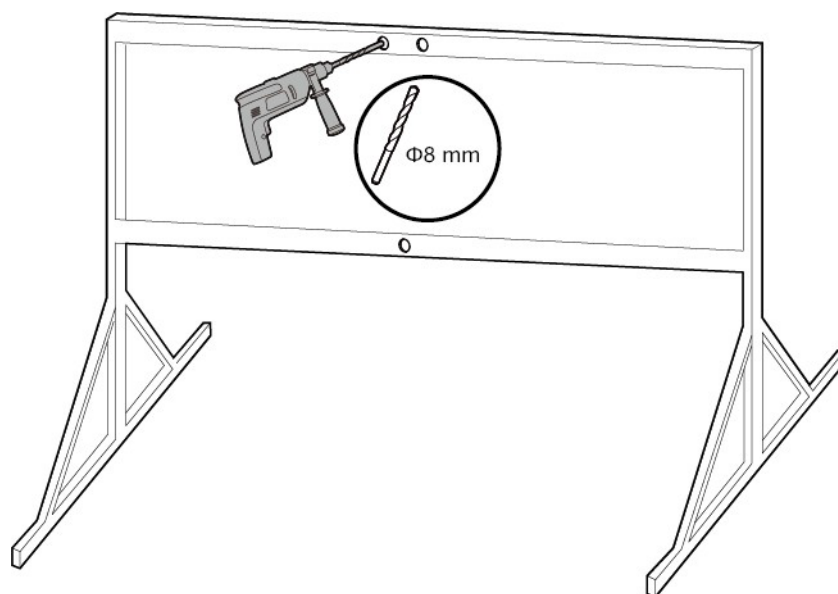
Figure 4-12 Determining hole positions

IH07H00011

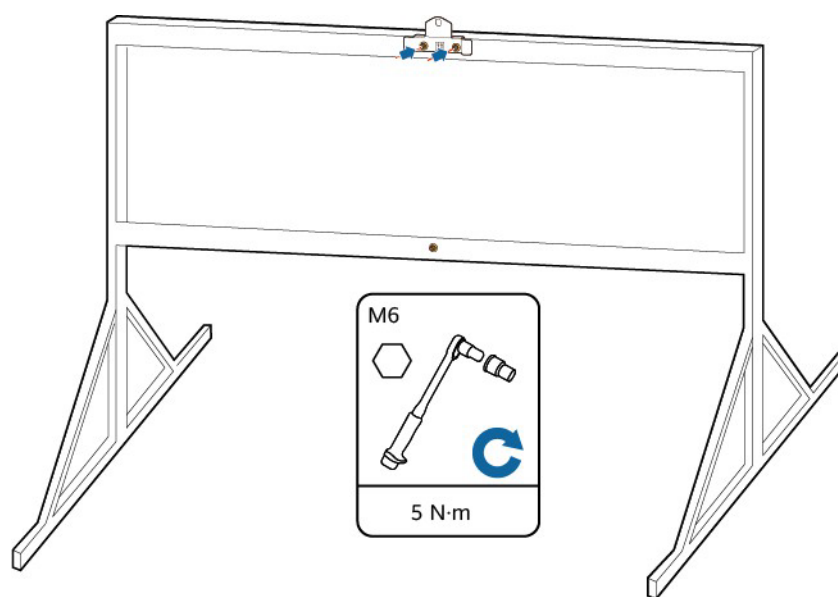
Step 2 Drill holes using a hammer drill.

NOTE

You are advised to apply anti-rust paint on the hole positions for protection.

Figure 4-13 Drilling holes

IH07H00012

Step 3 Secure the mounting bracket.**Figure 4-14** Securing the mounting bracket

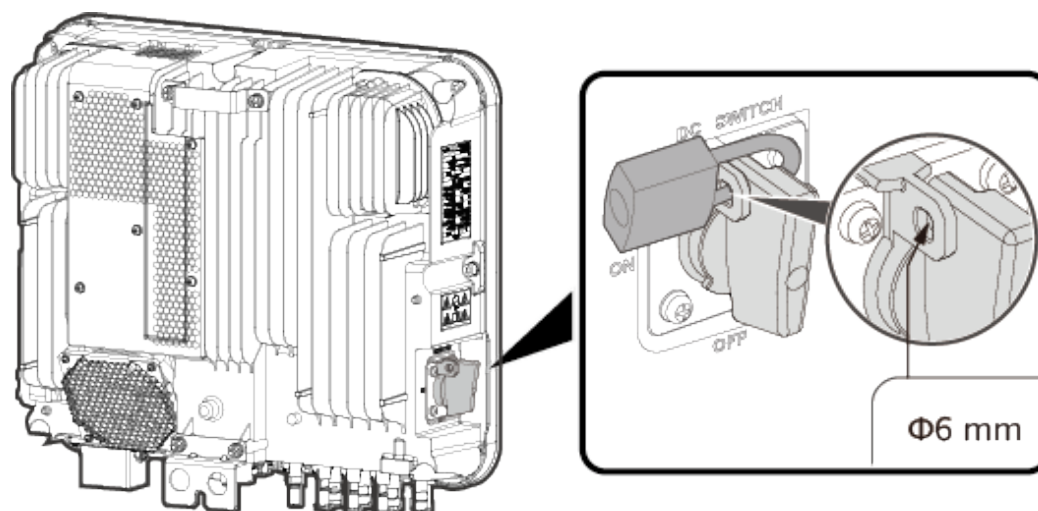
IH07H00013

NOTE

Prepare bolt assemblies based on the hole diameter of the mounting bracket.

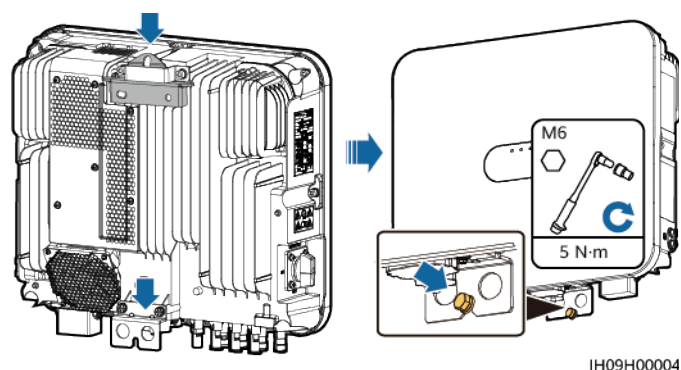
Step 4 Install the DC switch padlock.**NOTE**

For models used in Australia, the DC switch padlock needs to be installed according to the local standard to secure the DC switch (DC SWITCH) and prevent incorrect startup. The DC switch padlock needs to be prepared by the customer.

Figure 4-15 Installing the DC switch padlock

Step 5 Install the inverter on the mounting bracket.

Step 6 Tighten the bolt assemblies.

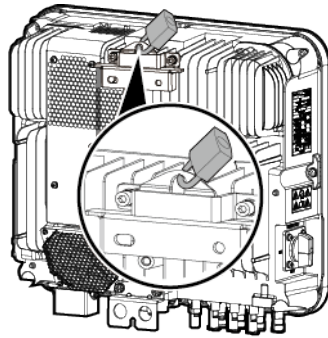
Figure 4-16 Tightening the bolt assemblies

Step 7 (Optional) Install an anti-theft lock.

NOTICE

- Prepare an anti-theft lock suitable for the lock hole diameter ($\Phi 10\text{ mm}$).
- An outdoor waterproof lock is recommended.
- Keep the key to the anti-theft lock.

Figure 4-17 Installing an anti-theft lock



IH09H0000E

----End

5 Electrical Connections

5.1 Precautions

 DANGER

When exposed to sunlight, the PV arrays supply DC voltage to the inverter. Before connecting cables, ensure that all **DC SWITCH** on the inverter are OFF. Otherwise, the high voltage of the inverter may result in electric shocks.

 DANGER

- The site must be equipped with qualified fire fighting facilities, such as fire sand and carbon dioxide fire extinguishers.
 - Wear personal protective equipment and use dedicated insulated tools to avoid electric shocks or short circuits.
-

 WARNING

- The equipment damage caused by incorrect cable connections is beyond the warranty scope.
 - Only certified electrician can perform electrical terminations.
 - Operation personnel must wear PPE when connecting cables.
 - Before connecting cables to ports, leave enough slack to reduce the tension on the cables and prevent poor cable connections.
-

 CAUTION

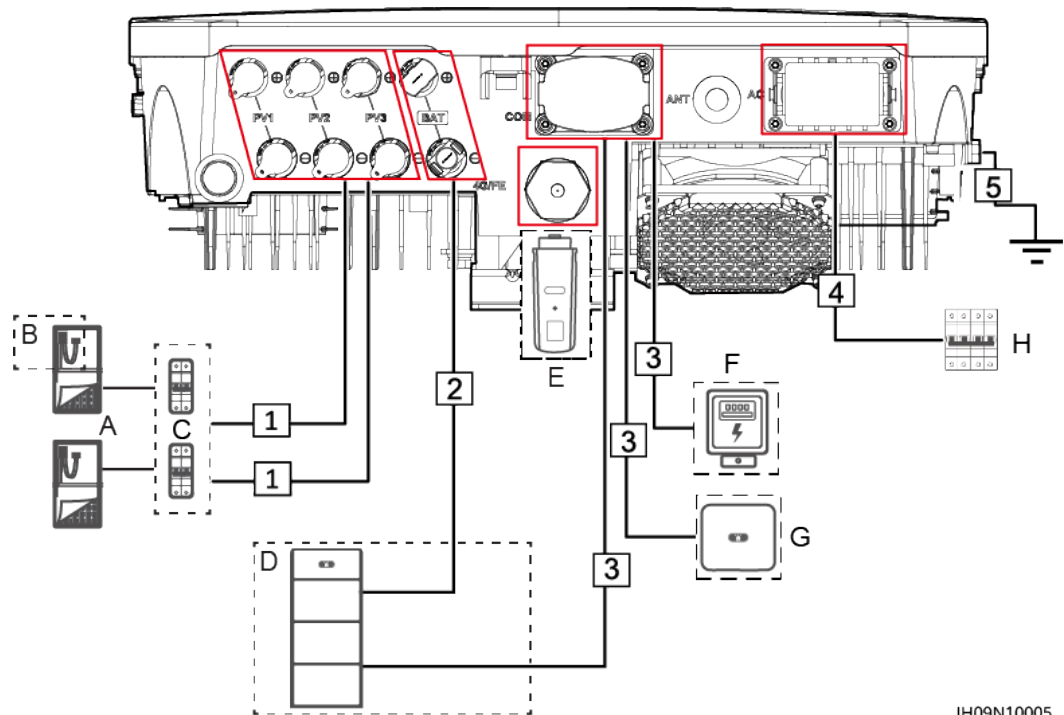
- Stay away from the equipment when preparing cables to prevent cable scraps from entering the equipment. Cable scraps may cause sparks and result in personal injury and equipment damage.
-

 NOTE

The cable colors shown in the electrical connection diagrams provided in this section are for reference only. Select cables in accordance with local cable specifications (green-and-yellow cables are only used for protective earthing).

5.2 Preparing Cables

Figure 5-1 Inverter cable connections (the components in dashed boxes are optional)



IH09N10005

Table 5-1 Component description

No.	Component	Description	Source
A	PV module	<ul style="list-style-type: none"> A PV string consists of PV modules connected in series. The inverter supports three PV string inputs.^[1] 	Prepared by the customer
B	Optimizer	The supported Optimizer models are SUN2000-450W-P2, and SUN2000-600W-P.	Purchased from provider
C	DC switch	Recommended: a DC circuit breaker with a rated voltage greater than or equal to 600 V DC and a rated current of 20 A	Prepared by the customer

No.	Component	Description	Source
D	Battery	The inverter can connect to the Energy Storage.	Purchased from provider
E	Smart Dongle	Supported models: WLAN-FE Smart Dongle	Purchased from provider
F	Power meter ^[2]	The recommended power meter models are DDSU666-H, YDS70-C16, DDSU71 and DDSU1079-CT.	Purchased from provider
G	Inverter	In the inverter cascading scenario, a maximum of three inverters can be cascaded.	Purchased from provider
H	AC switch	To ensure that the inverter can be safely disconnected from the power grid when an exception occurs, connect an AC switch to the AC side of the inverter. Select an appropriate AC switch in accordance with local industry standards and regulations. The following switch specifications are recommended: a single-phase AC circuit breaker with a rated voltage greater than or equal to 250 V AC and a rated current of: <ul style="list-style-type: none"> • 32 A for the 5kW inverter • 50 A for the 8kW inverter • 63 A for the 10kW inverter 	Prepared by the customer
<p>Note [1]: Do not connect only one PV string to the inverter.</p> <p>Note [2]: Retain the default baud rates for the power meters. If they are changed, the power meters may go offline, generate alarms, or affect the inverter output power.</p>			

Table 5-2 Cable description

No.	Cable	Type	Recommended Specifications	Source
1	DC input power cable	Common outdoor PV cable in the industry	<ul style="list-style-type: none"> • Conductor cross-sectional area: 4-6 mm² • Cable outer diameter: 5.5-9 mm 	Prepared by the customer

No.	Cable	Type	Recommended Specifications	Source
2	(Optional) Battery cable	Common outdoor PV cable in the industry	<ul style="list-style-type: none"> • Conductor cross-sectional area: 4-6 mm² • Cable outer diameter: 5.5-9 mm 	Prepared by the customer
3	(Optional) Signal cable	Outdoor shielded twisted pair cable	<ul style="list-style-type: none"> • Conductor cross-sectional area: <ul style="list-style-type: none"> - Combined crimping of cables on the port: 0.2-0.35 mm² - Crimping the cables on the port without combining them: 0.2-1 mm² • Cable outer diameter: 4-8 mm 	Prepared by the customer
4	AC output power cable ^a	Using the PE equipotential bonding point at the AC output port: three-core (L, N, and PE) outdoor copper cable	<ul style="list-style-type: none"> • Conductor cross-sectional area: <ul style="list-style-type: none"> - 5kW inverter: 6 mm² - 8kW inverter: 8-10 mm² - 10kW inverter: 10 mm² • Cable outer diameter: 16-21 mm 	Prepared by the customer
5	PE cable	Single-core outdoor copper cable and M6 OT terminal	10 mm ²	Prepared by the customer
<p>Note a: The minimum cross-sectional area should be determined based on the rated value of the AC fuse.</p>				

 NOTE

- The minimum cable cross-sectional area must meet local standards.
- The factors to be considered in cable selection include the rated current, cable type, routing mode, ambient temperature, and maximum acceptable line loss.

5.3 Connecting a PE Cable

Precautions

 **DANGER**

- Ensure that the PE cable is securely connected. Otherwise, electric shocks may occur.
- Do not connect the neutral wire to the enclosure as a PE cable. Otherwise, electric shocks may occur.

 NOTE

- The PE point at the AC output port is used only as a PE equipotential bonding point, and cannot substitute for the PE point on the enclosure.
- It is recommended that silicone grease or paint be applied around the ground terminal after the PE cable is connected.
- If an Earth Fault Alarm occurs, LED1 and LED2 on the inverter will go red and fault code will appear in both HiSolar (local app) and Univers (remote app) - Refer to Section 8.6

Additional Information

The inverter provides the grounding detection function. This function is used to check whether the inverter is properly grounded before the inverter starts, or check whether the ground cable is disconnected when the inverter is running. This function is only available under limited conditions. To ensure the safe operation of the inverter, properly ground the inverter according to the connection requirements of the PE cable. For some power grid types, if the output side of the inverter is connected to an isolation transformer, ensure that the inverter is properly grounded and then set **Grounding Exception Detection** to **Disable** so that the inverter can run properly.

- According to IEC 62109, to ensure the safe operation of the inverter in the case of PE cable damage or disconnection, properly connect the PE cable of the inverter and ensure that it meets at least one of the following requirements before the grounding detection function becomes invalid.
 - If the PE terminal of the AC connector is not connected, the PE cable on the enclosure must be a single-core outdoor copper cable with a cross-sectional area of at least 10 mm².
 - Use cables with the same diameter as the AC output power cable and ground the PE terminal on the AC connector and the ground screws on the enclosure.
- In some countries and regions, the inverter must have additional ground cables. In this case, use cables with the same diameter as the AC output power cable to ground the PE terminal of the AC connector and the ground screws of the enclosure, respectively.

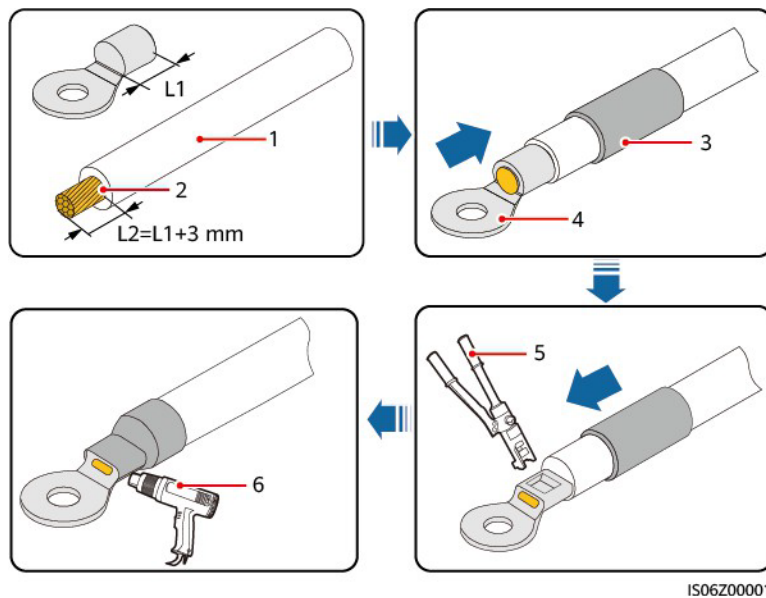
Procedure

Step 1 Crimp an OT terminal.

NOTICE

- Avoid scratching the core wire when stripping a cable.
- The cavity formed after the conductor crimp strip of the OT terminal is crimped must wrap the core wire completely. The core wire must make close contact with the OT terminal.
- Wrap the wire crimping area with heat shrink tubing or insulation tape. The heat shrink tubing is used as an example.
- Use a heat gun carefully to avoid heat damage to the equipment.

Figure 5-2 Crimping an OT terminal

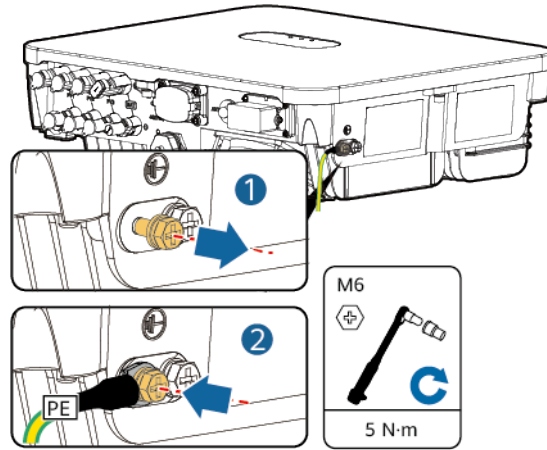


IS06Z00001

- | | | |
|-----------------|----------------------|------------------------|
| (1) Cable | (2) Core wire | (3) Heat shrink tubing |
| (4) OT terminal | (5) Hydraulic pliers | (6) Heat gun |

Step 2 Connect the PE cable.

Figure 5-3 Connecting the PE cable



IH09150001

----End

5.4 Connecting an AC Output Power Cable

Precautions

An AC switch should be installed on the AC side of the inverter. To ensure that the inverter can safely disconnect itself from the power grid when an exception occurs, select a proper overcurrent protection device in compliance with local power distribution regulations.

⚠ WARNING

- Do not connect loads between an inverter and an AC switch that directly connects to the inverter. Otherwise, the switch may trip by mistake.
- If an AC switch is used with specifications beyond local standards, regulations, or the Company's recommendations, the switch may fail to turn off in a timely manner in case of exceptions, causing serious faults.

⚠ CAUTION

Each inverter shall be equipped with an AC output switch. Multiple inverters shall not connect to the same AC switch.

The inverter is installed with an integrated monitoring unit for residual current. When the inverter detects that residual current exceeds the permitted value, it disconnects from the power grid quickly.

NOTICE

- If required a Type A RCD (Residual Current Device) can be used for these inverter models in the distribution panel
 - If the external RCD provides the leakage protection function, the rated leakage tripping current must be greater than or equal to 100 mA.
 - If multiple inverters are connected to the master leakage protection device through their RCD, the rated leakage tripping current of the device must be greater than or equal to the number of inverters x 100 mA.
 - The RCD cannot be a knife switch.
-

Procedure

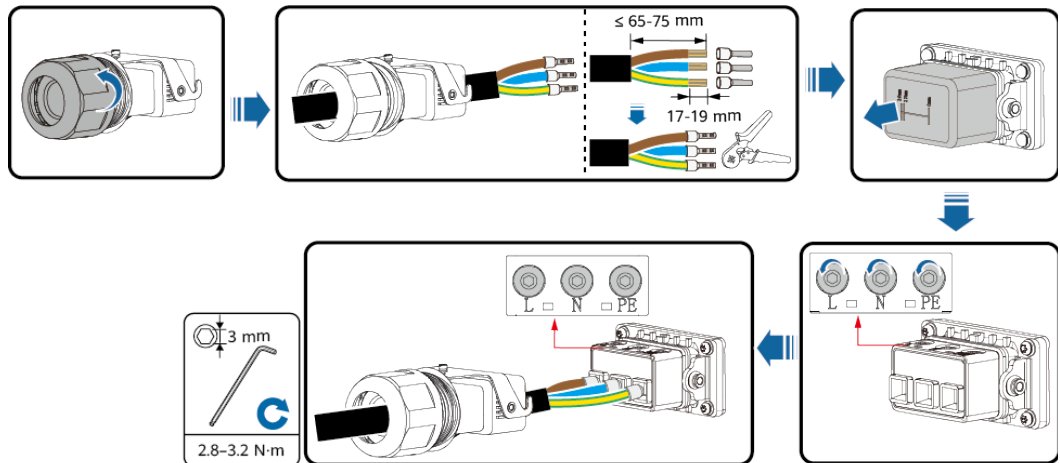
Step 1 Connect the AC output power cable to the AC connector.

NOTICE

- The PE point at the AC output port is used only as a PE equipotential point, and cannot substitute for the PE point on the enclosure.
 - Keep the AC output power cable and the PE cable close to each other.
 - Keep the AC output power cable and the DC input power cable close to each other.
 - Ensure that the cable jacket is inside the connector.
 - Ensure that the exposed core is totally inserted into the cable hole.
 - Ensure that AC output cable is secured. Failing to do so may cause device malfunction or damage to its AC connector.
 - Ensure that the cable is not twisted.
-

NOTICE

Strip the insulation layers of the AC output power cable by the recommended length (17-19 mm) and crimp the cable conductors with the delivered cord end terminals. Ensure that the cord end terminals are completely inside the conductor insertion points. Tighten the cable conductors to a torque of 2.8-3.2 N·m. Otherwise, the device may fail to run properly or be damaged during operation.

Figure 5-4 Installing the AC power cable

IH09120001

NOTE

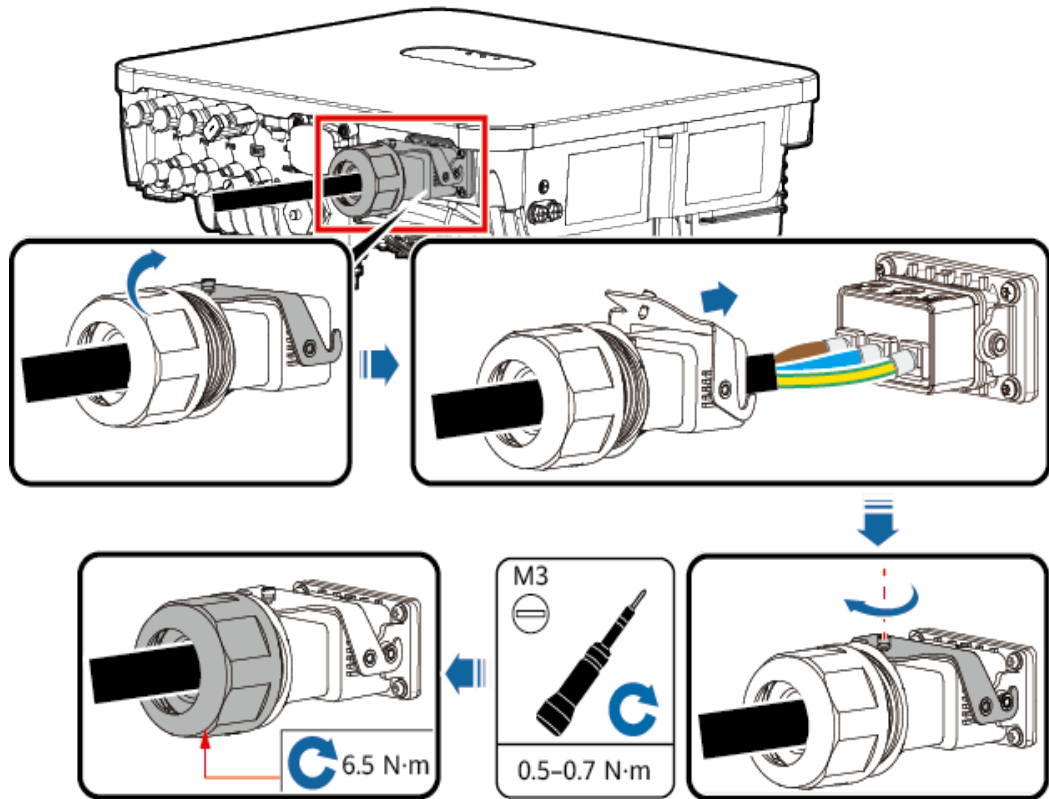
The cable colors shown in the figures are for reference only. Select an appropriate cable according to the local standards.

Step 2 Connect the AC connector to the AC output port.

NOTICE

Ensure that the AC connector is connected securely.

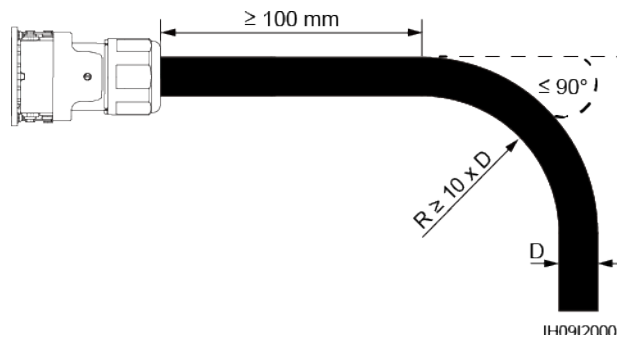
Figure 5-5 Securing the AC connector



IH09H00007

Step 3 Check the route of the AC output power cable.

Figure 5-6 Cabling requirements



IH09H00007

----End

Disconnection

Perform the steps in reverse order to disconnect the cable.

5.5 Connecting DC Input Power Cables

Precautions

 DANGER

- Before connecting the DC input power cables, ensure that the DC voltage is within the safe range (lower than 60 V DC) and that the DC switch on the inverter is OFF. Failing to do so may result in electric shocks.
 - When the inverter is running, it is not allowed to work on the DC input power cables, such as connecting or disconnecting a PV string or a PV module in a PV string. Failing to do so may cause electric shocks.
 - If no PV string connects to a DC input terminal of the inverter, do not remove the watertight cap from the DC input terminals. Otherwise, the IP rating of the inverter will be affected.
-

 WARNING

Ensure that the following conditions are met. Otherwise, the inverter may be damaged, or even a fire could happen.

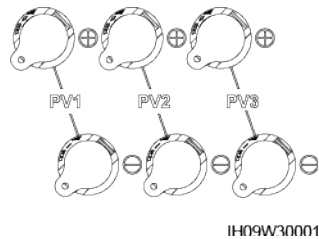
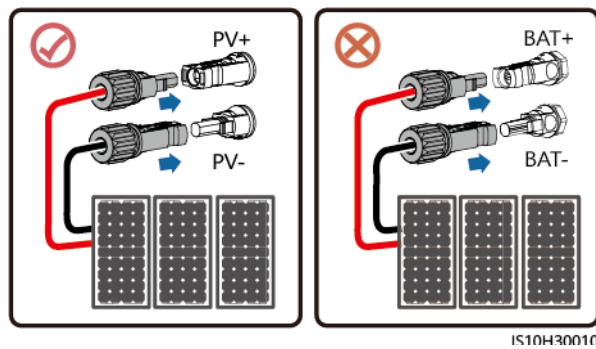
- The DC input voltage of the inverter shall not exceed maximum input voltage under any circumstance.
 - The polarities of electric connections are correct on the DC input side. The positive and negative terminals of a PV string connect to corresponding positive and negative DC input terminals of the inverter.
 - If the DC input power cables are reversely connected, do not operate the DC switch as well as positive and negative connectors immediately. Wait until the night when solar irradiance declines and the PV string current drops to below 0.5 A. Then set the DC switch to the OFF position, remove the positive and negative connectors, and correct the polarities of the DC input power cables.
-

 WARNING

During the installation of PV strings and the inverter, the positive or negative terminals of PV strings may be short-circuited to ground if the power cables are not properly installed or routed. In this case, an AC or DC short circuit may occur and damage the inverter. The resulting device damage is not covered under any warranty.

NOTICE

Since the output of the PV string connected to the inverter cannot be grounded, ensure that the PV module output is well insulated to ground.

Terminal Description**Figure 5-7** DC input terminals**Figure 5-8** Connection**Procedure**

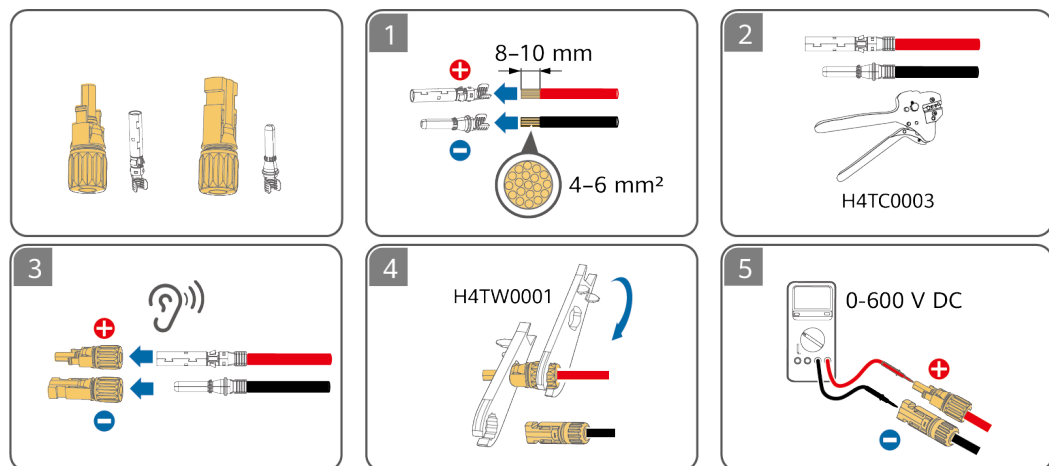
Step 1 Assemble DC connectors.

CAUTION

Use the positive and negative metal terminals and DC connectors delivered with the inverter. Using incompatible positive and negative metal terminals and DC connectors may result in serious consequences. The caused device damage is not covered under any warranty or service agreement.

NOTICE

- Keep the DC input PV+ cable and PV- cable close to each other.
- Cables with high rigidity, such as armored cables, are not recommended as DC input power cables, because poor contact may be caused by the bending of the cables.
- Before assembling DC connectors, label the cable polarities correctly to ensure correct cable connections.
- After crimping the positive and negative metal terminals, pull the DC input power cables back to ensure that they are connected securely.
- Insert the crimped metal terminals of the positive and negative power cables into the appropriate positive and negative connectors. Then pull back the DC input power cables to ensure that they are connected securely.
- During DC input power cabling, leave at least 50 mm of slack. The axial tension on PV connectors must not exceed 80 N. Radial stress or torque must not be generated on PV connectors.

Figure 5-9 Assembling DC connectors**NOTE**

- If the PV string is not configured with an optimizer, use a multimeter to measure the voltage at the DC position. The multimeter must have a DC voltage range of at least 600 V. If the voltage is a negative value, the DC input polarity is incorrect and needs correction. If the voltage is greater than 600 V, too many PV modules are configured to the same string. Remove some PV modules.

WARNING

Before performing **Step 2**, ensure that the **DC SWITCH** is set to **OFF**.

Step 2 Insert the positive and negative connectors into corresponding DC input terminals on the inverter.

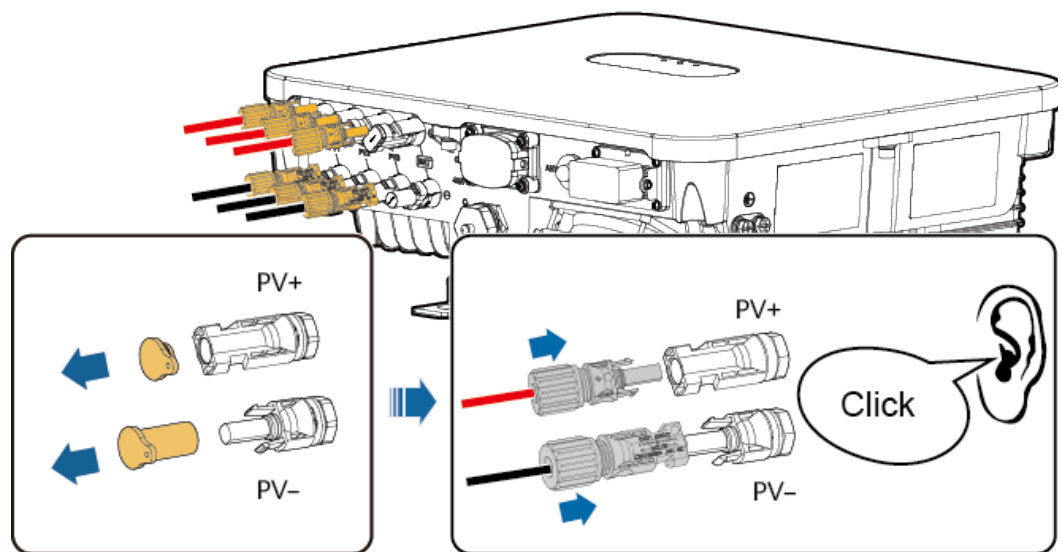
NOTICE

After the positive and negative connectors snap into place, pull the DC input power cables back to ensure that they are connected securely.

NOTICE

During DC input power cabling, leave at least 50 mm of slack. The axial tension on PV connectors must not exceed 80 N. Radial stress or torque must not be generated on PV connectors.

Figure 5-10 Connecting DC input power cables



IH09I30001

NOTICE

If the DC input power cable is reversely connected and the DC switch is set to ON, do not immediately turn off the DC switch or reconnect the positive and negative connectors. Otherwise, the device may be damaged. The caused device damage is not covered under any warranty or service agreement. Wait until the night when solar irradiance declines and the PV string current drops to below 0.5 A. Then set the DC switch to the OFF position, remove the positive and negative connectors, and correct the polarities of the DC input power cables.

----End

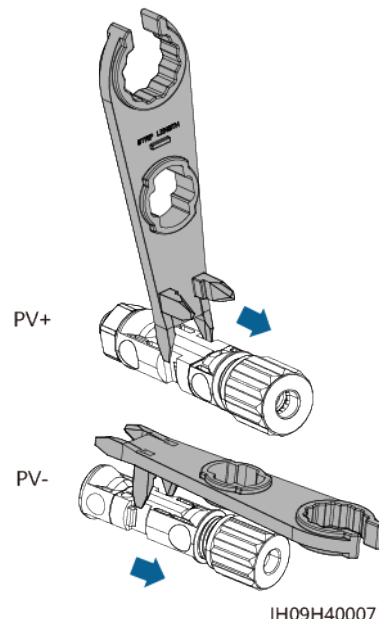
Removing DC Connectors

⚠ WARNING

Before removing the positive and negative connectors, ensure that the DC SWITCH is set to OFF.

To remove the positive and negative connectors from the inverter, insert an open-end wrench into the notch and press the wrench with an appropriate force.

Figure 5-11 Removing a DC connector



5.6 (Optional) Connecting Battery Cables

Prerequisites

 DANGER

- Battery short circuits may cause personal injury. The high transient current generated by a short circuit may release a surge of power and cause fire.
- Do not connect or disconnect the battery cable when the inverter is running. Failing to do so may cause electric shocks.
- Before connecting the battery cables, ensure that the DC switch on the inverter and all the switches connecting to the inverter are OFF, and the inverter has no residual electricity. Otherwise, the high voltage of the inverter and battery may result in electric shocks.
- If no battery connects to the inverter, do not remove the watertight cap from the battery terminal. Otherwise, the IP rating of the inverter will be affected. If a battery connects to the inverter, set aside the watertight cap. Reinstall the watertight cap immediately after removing the connector. The high voltage of the battery terminal may result in electric shocks.

A battery switch can be configured between the inverter and the battery to ensure that the inverter can be safely disconnected from the battery.

 WARNING

- Do not connect loads between the inverter and the battery.
- The battery cables should be connected correctly. That is, the positive and negative terminals of the battery connect to the positive and negative battery terminals on the inverter respectively. Otherwise, the inverter may be damaged, or even a fire could happen.

 WARNING

During the installation of the ESS and the inverter, the positive or negative terminal of the ESS may be short-circuited to ground if the power cables are not properly installed or routed. In this case, an AC or DC short circuit may occur and damage the devices. The resulting device damage is not covered under any warranty.

Procedure

- Step 1** Assemble the positive and negative connectors by referring to [5.5 Connecting DC Input Power Cables](#).

⚠ DANGER

- The battery voltage will result in serious injury. Use dedicated insulation tools to connect cables.
- Ensure that cables are correctly connected between the battery terminal and the battery switch, and between the battery switch and the inverter battery terminal.

NOTICE

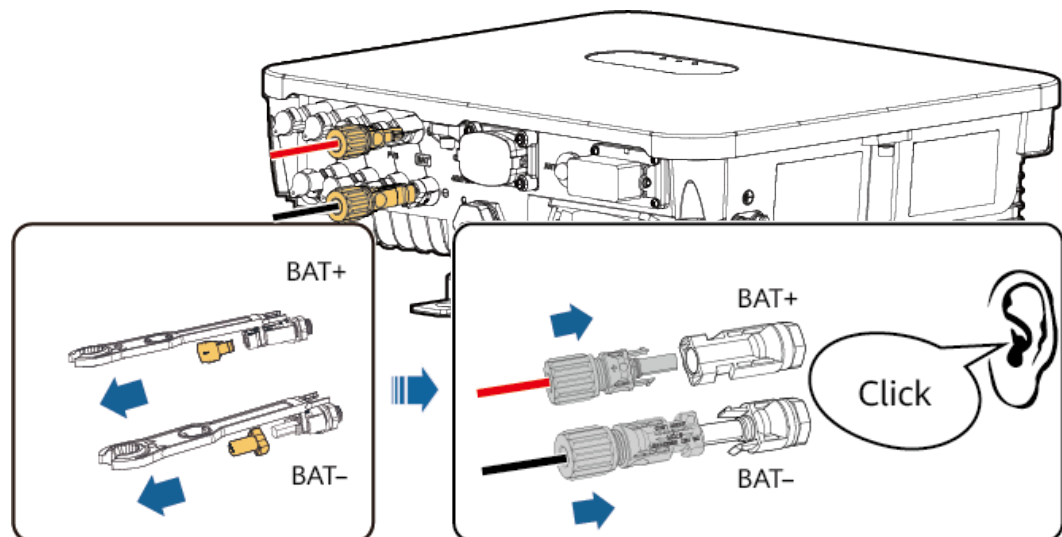
Cables with high rigidity, such as armored cables, are not recommended as battery cables, because poor contact may be caused by the bending of the cables.

Step 2 Insert the positive and negative connectors into corresponding battery terminals of the inverter.

NOTICE

After the positive and negative connectors snap into place, pull the battery cables back to ensure that they are connected securely.

Figure 5-12 Connecting battery cables



IH09I30002

----End

External Electrical Connections of Battery Side

NOTE

The DC-DC converter has a COM port on both sides. When batteries are connected in parallel, you are advised to connect the inverter to the COM port on the right side and connect the cascaded batteries to the COM port on the left side.

NOTICE

The COM ports on the two sides of the DC-DC converter are symmetrical and in different directions. Insert the cables to the COM ports in the directions shown in the figure.

Figure 5-13 - Single-phase inverter

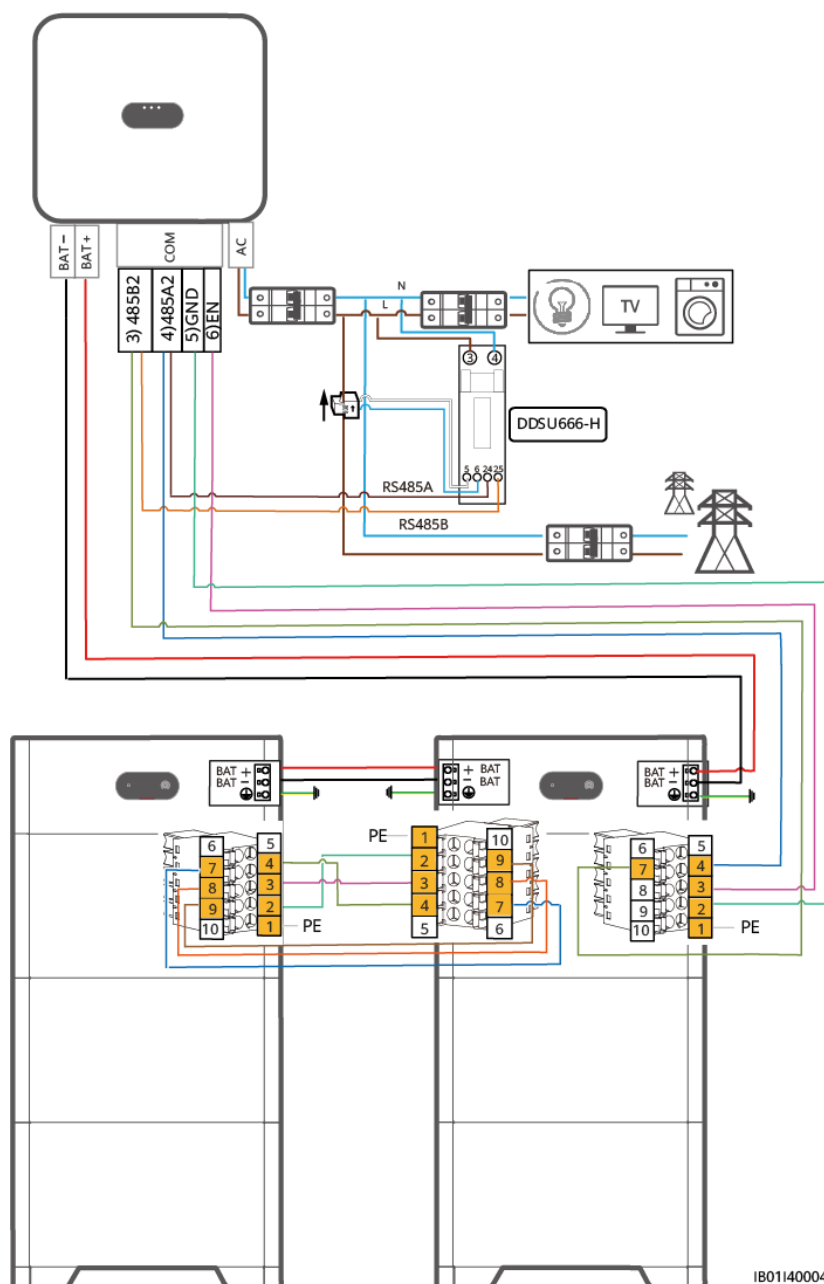
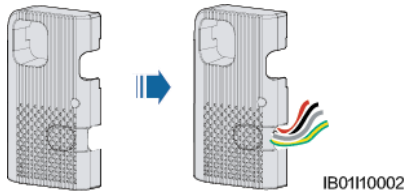


Figure 5-14 Routing cables out of the cable hole**NOTICE**

Before connecting external cables, route the cables through the cable hole to avoid disconnecting after installation.

Installing a PE Cable**Precautions****⚠ DANGER**

Ensure that the PE cable is securely connected. Otherwise, electric shocks may occur.

📖 NOTE

It is recommended that silica gel or paint be used around the ground terminal after the PE cable is connected.

Procedure

Crimp an OT terminal.

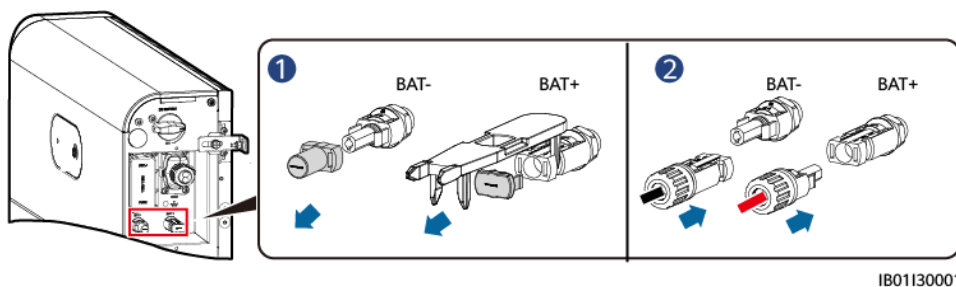
Installing DC Input Power Cables

Connect DC input power cables to the inverter

Insert the positive and negative battery connectors (Staubli) into the corresponding DC input terminals (BAT+ and BAT-).

📖 NOTE

The DC input terminals (BAT+ and BAT-) on the left and right sides of the battery are the same. Assemble DC connectors.

Figure 5-15 Connecting battery cables

----End

Installing a Signal Cable (BMS)

Connecting the Signal Cable between the Power Control Module (BMS) and the Inverter

NOTICE

When laying out a signal cable, separate it from power cables and keep it away from strong interference sources to prevent communication interruption.

The COM port definitions on both sides of the power control module are the same. It is recommended that the COM port on the switch side be connected to the inverter and the COM port on the other side be connected to the cascaded battery.

Figure 5-16 Signal cable ports

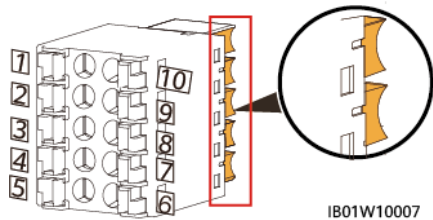
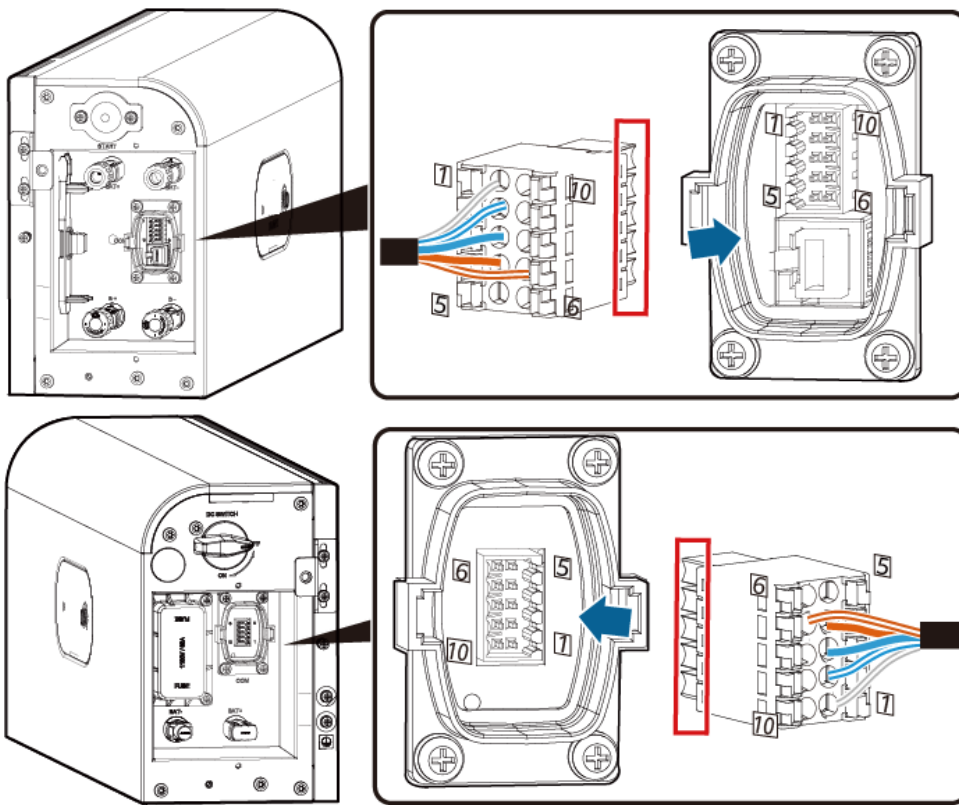


Table 5-1 COM port definition

No.	Label	Definition	Description
1	PE	Shield layer grounding	Shield layer grounding
2	Enable-	Enable signal GND	Connects to the enable signal GND of the inverter.
3	Enable+	Enable signal+	Connects to the positive enable signal of the inverter.
4	485A	RS485A, RS485 differential signal+	Connects to the RS485 signal port + of the inverter or cascaded battery.
5			
6	485B	RS485B, RS485 differential signal-	Connects to the RS485 signal port - of the inverter or cascaded battery.
7			
8	CANL	Extended CAN bus port	Used for signal cable cascading in battery cascading scenarios.
9	CANH	Extended CAN bus port	Used for signal cable cascading in battery cascading scenarios.
10	PE	Shield layer grounding	Shield layer grounding

Figure 5-16 Inserting the terminal



IB01W10008

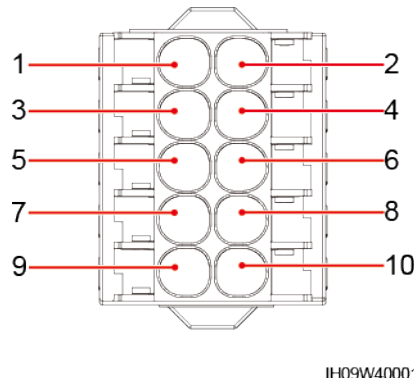
5.7 Connecting Signal Cables

COM Port Pin Definitions

NOTICE

- When laying out a signal cable, separate it from power cables and keep it away from strong interference sources to prevent communication interruption.
- Ensure that the protection layer of the signal cable is inside the connector, surplus core wires are cut off from the protection layer, the exposed core wires are inserted completely into the holes, and the cable is connected securely.
- If the Smart Dongle is configured, you are advised to install the Smart Dongle before connecting the signal cable.

Figure 5-13 Pin definitions



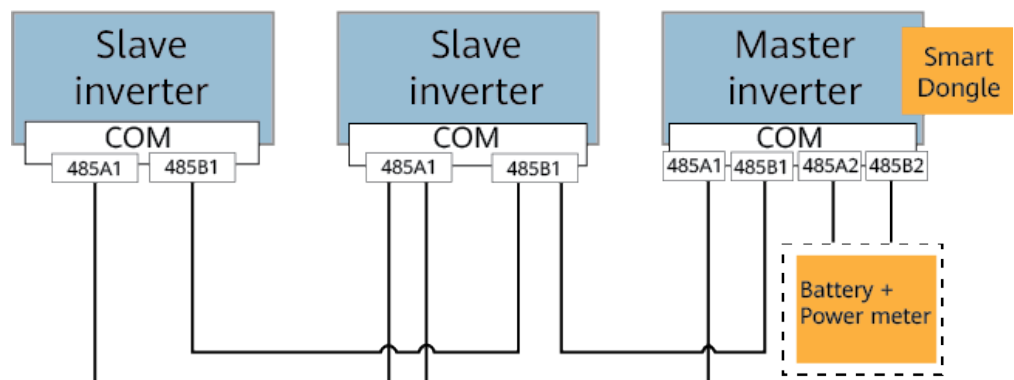
Pin	Definition	Function	Description
1	485B1	RS485B, RS485 differential signal-	Used to connect to the RS485 signal ports of the cascaded inverters.
2	485A1	RS485A, RS485 differential signal+	
3	485B2	RS485B, RS485 differential signal-	Used to connect to the RS485 signal ports on the batteries and power meters. When batteries and power meters coexist, they share the 485B2 and 485A2 ports.
4	485A2	RS485A, RS485 differential signal+	
5	GND	GND	Used to connect to the GND of the enable signal/DI1/DI2 of the battery.
6	EN+	Enable signal	Used to connect to the enable signal of the battery.

Pin	Definition	Function	Description
7	DI1	Digital input signal 1+	Used to connect to the positive terminal of DI1. It can connect to the DRMO scheduling signal or serve as a port for rapid shutdown signals.
8	DI2	Digital input signal 2+	Used to connect to the positive terminal of DI2.
9	GND	GND	Used to connect to the GND of the enable signal/DI1/DI2 of the battery.
10	PE	Shield layer grounding	-

Communication Networking Mode

- Smart Dongle networking

Figure 5-14 Smart Dongle networking (the components in the dashed box are optional)



NOTE

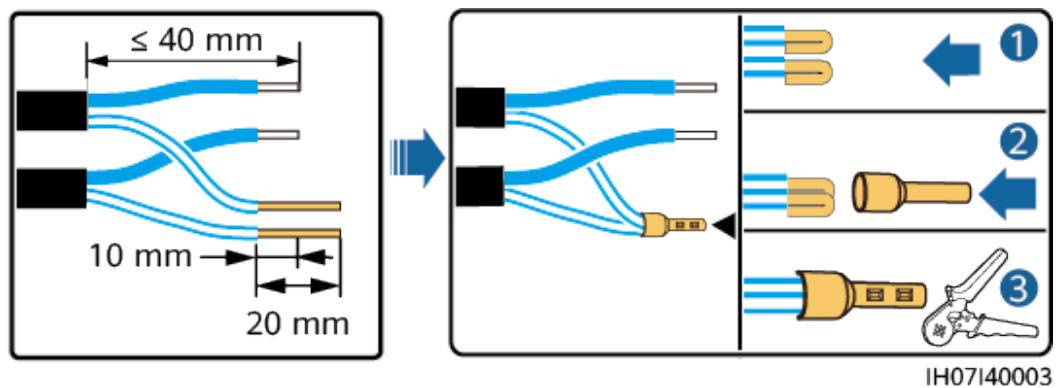
- The power meter and the Smart Dongle must be connected to the same inverter.
- In the preceding networking, the inverters are cascaded and support the grid-tied point control function to achieve zero export.
- If the inverters require the grid-tied point control function, they need to be connected to a power meter.

Requirements for Signal Cables

NOTICE

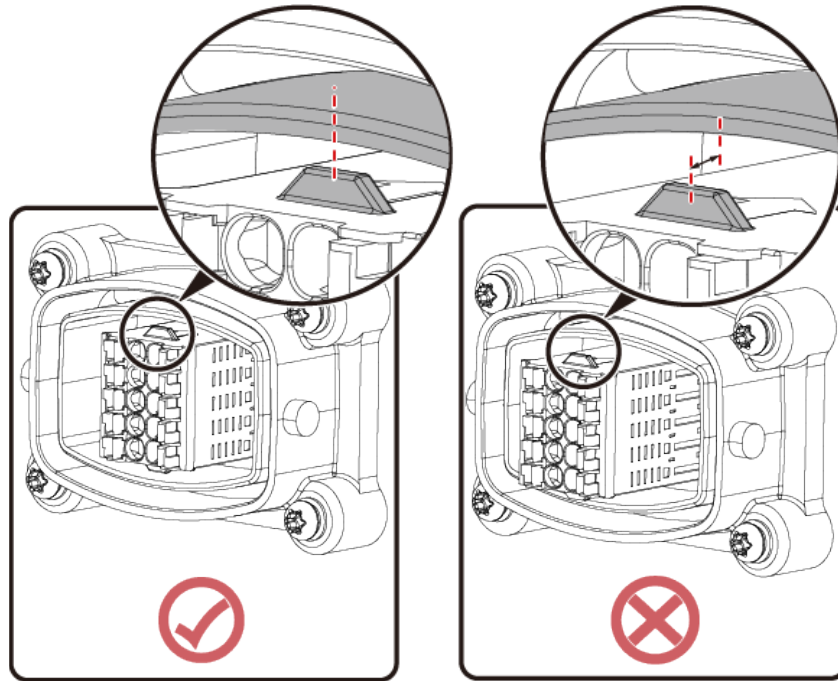
- Ensure that the protection layer of the cable is in the connector. The surplus core should be cut off from the protection layer.
- Ensure that the exposed core is totally inserted into the cable hole.
- Ensure that the signal cables are connected securely.
- Ensure that the cables are not twisted.
- If multiple signal cables need to be connected to a single connector, ensure that the outer diameters of the signal cables are the same.

Figure 5-15 Crimping two signal cables



Requirements for Installing the Signal Cable Connector Block

When you install a connector block in the inverter, align the top of the connector block with the outer edge of the COM port, as shown in the following figure.

Figure 5-16 Installing the connector block

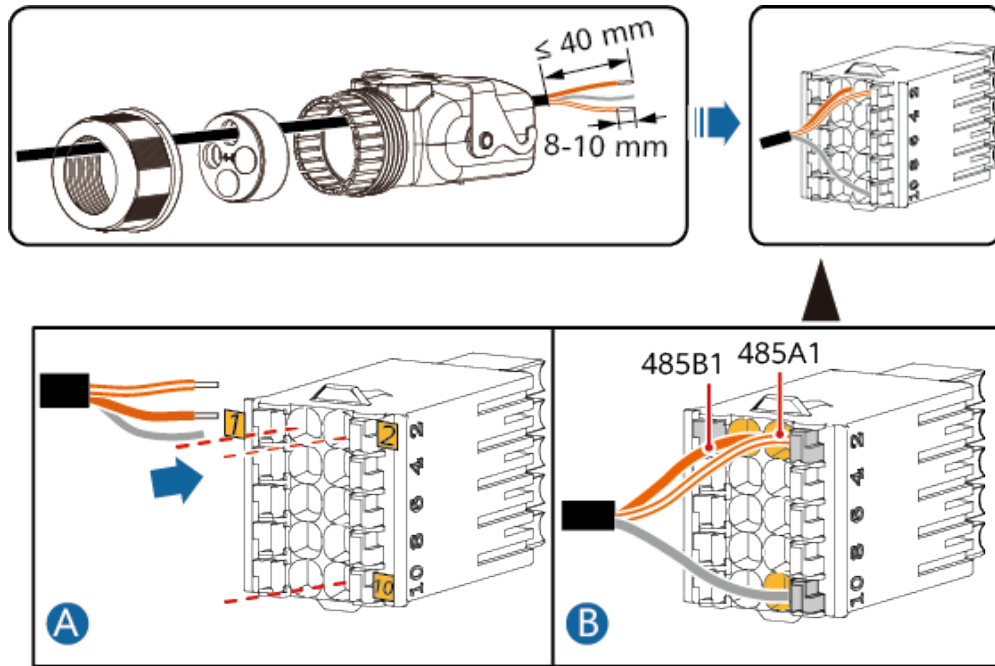
IH09H40006

5.7.1 Connecting RS485 Communications Cables (Inverter Cascading)

Procedure

Step 1 Connect the signal cable to the signal cable connector block.

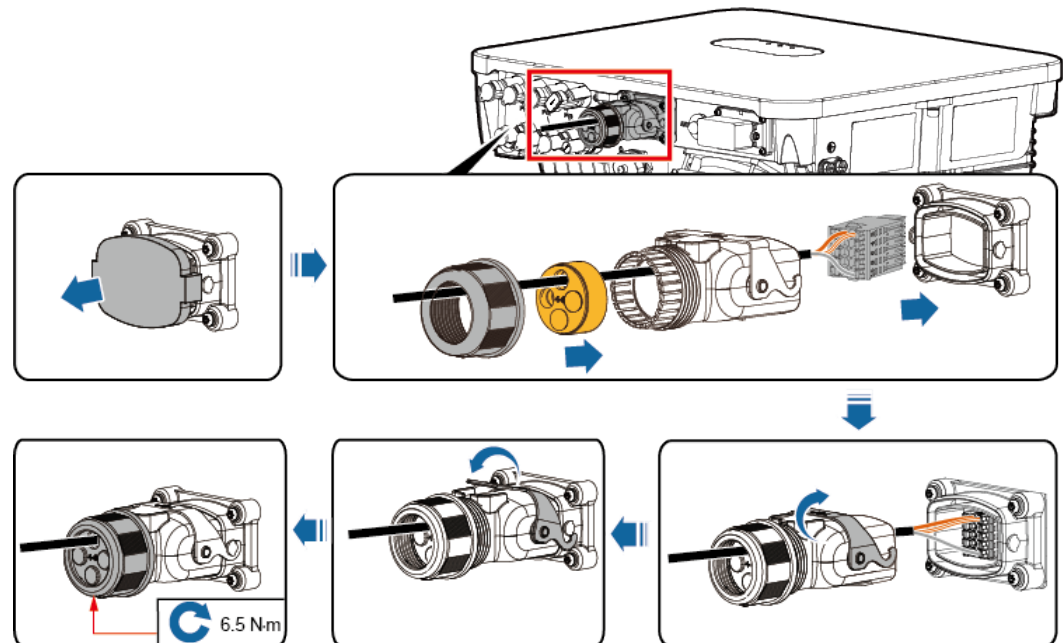
Figure 5-17 Installing the cable



IH09I40001

Step 2 Connect the signal cable connector to the COM port.

Figure 5-18 Securing the signal cable connector



IH09H40001

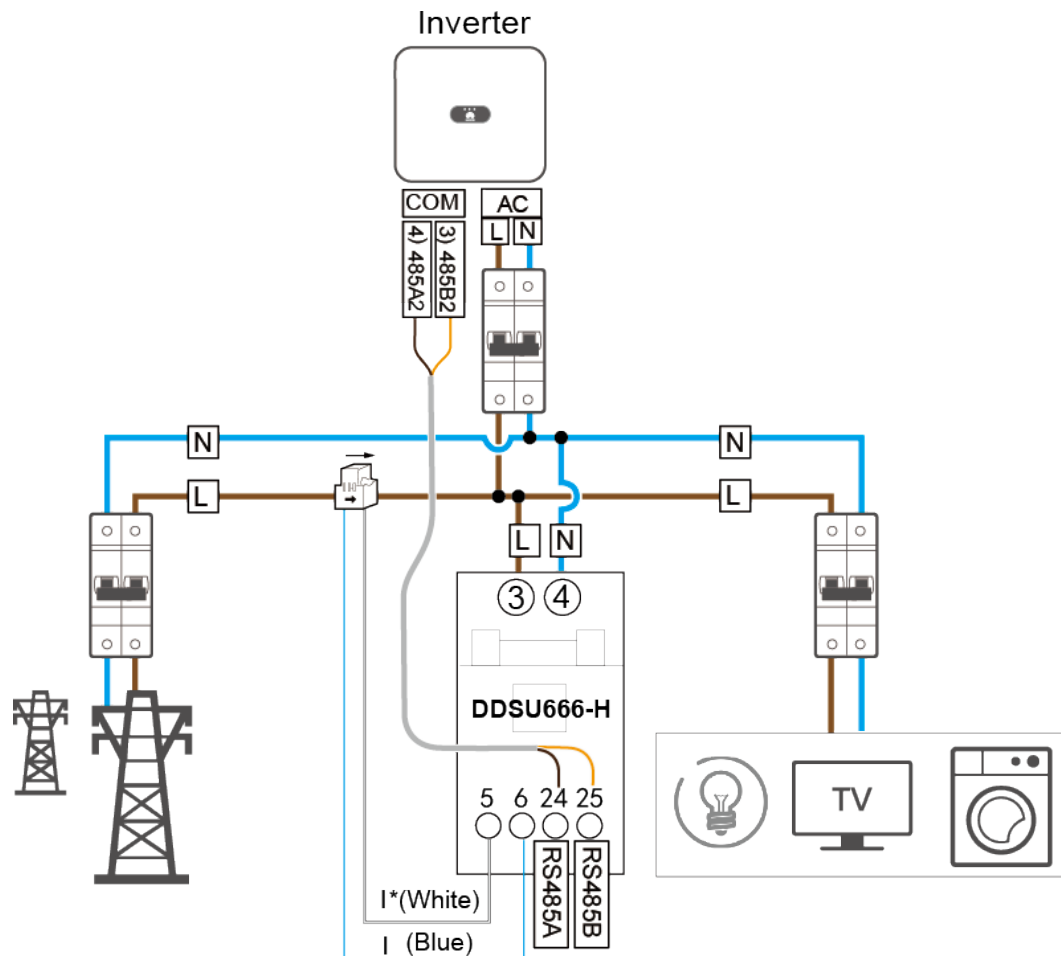
----End

5.7.2 Connecting RS485 Communications Cables (Power Meter and Battery)

Cable Connections

The following figure shows the cable connections between the inverter and the DDSU666-H power meter.

Figure 5-19 Connecting cables to the DDSU666-H power meter



NOTE

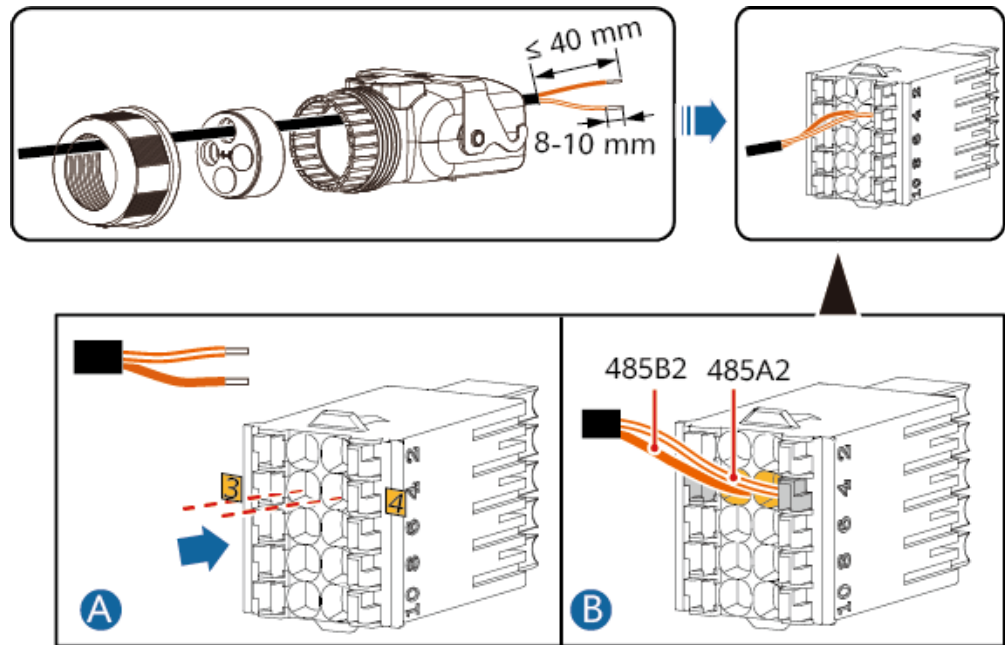
- The power meter and the Smart Dongle must be connected to the same inverter.
- Retain the default baud rates for the power meters. If they are changed, the power meters may go offline, generate alarms, or affect the inverter output power.
- The preceding networking uses DDSU666-H as an example. Cable connections for other meter models may vary.

Procedure

Step 1 Connect the signal cable to the signal cable connector block.

- Connecting the inverter to the power meter

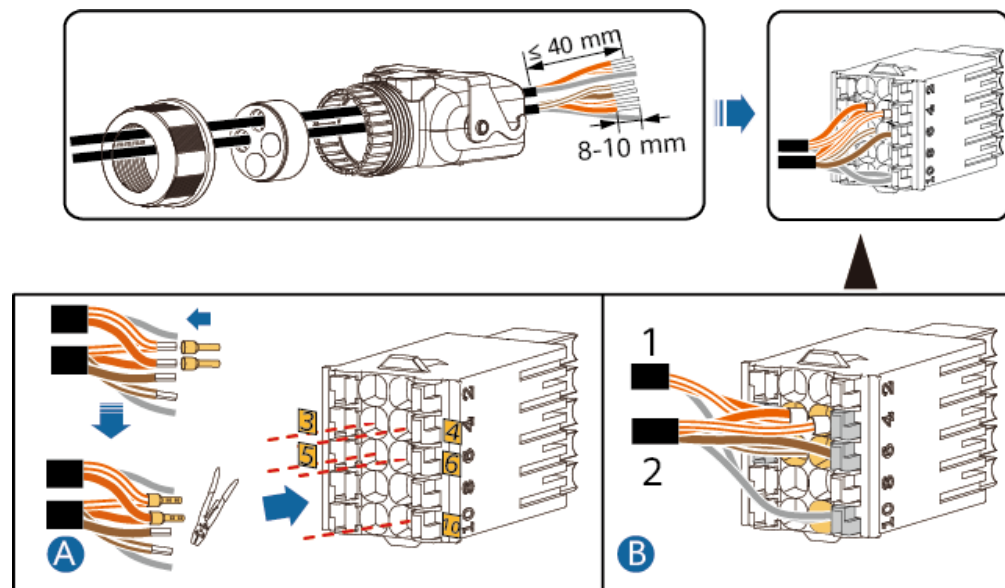
Figure 5-20 Installing the cable (connecting to the power meter)



IH09140006

- Connecting the power meter and battery to the inverter





Figure 5-21 Installing cables (connecting to the power meter and battery)



IH09140007

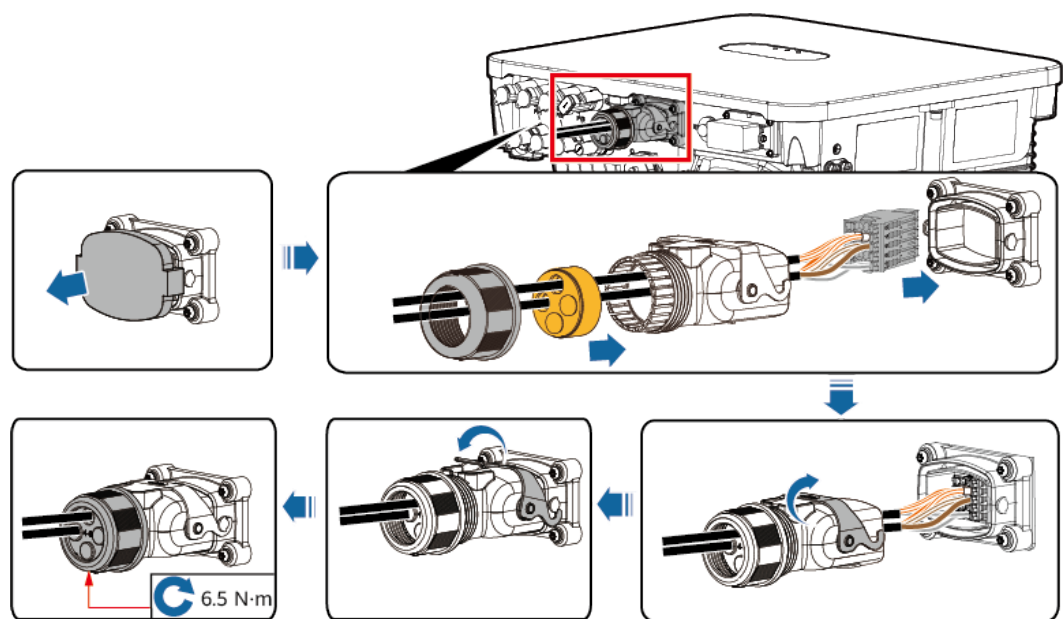
Table 5-3 Cable connections

Cable		Pin	Definition	To	
I		3	485B2	Power meter	485B
		4	485A2		485A

Cable	Pin	Definition	To		
2		3	485B2	Battery	
		4	485A2		485B
		5	GND		485A
		6	EN+		Enable-
					Enable+

Step 2 Connect the signal cable connector to the COM port.

Figure 5-22 Securing the signal cable connector



IH09H40005

----End

5.7.3 Connecting Rapid Shutdown Signal Cables

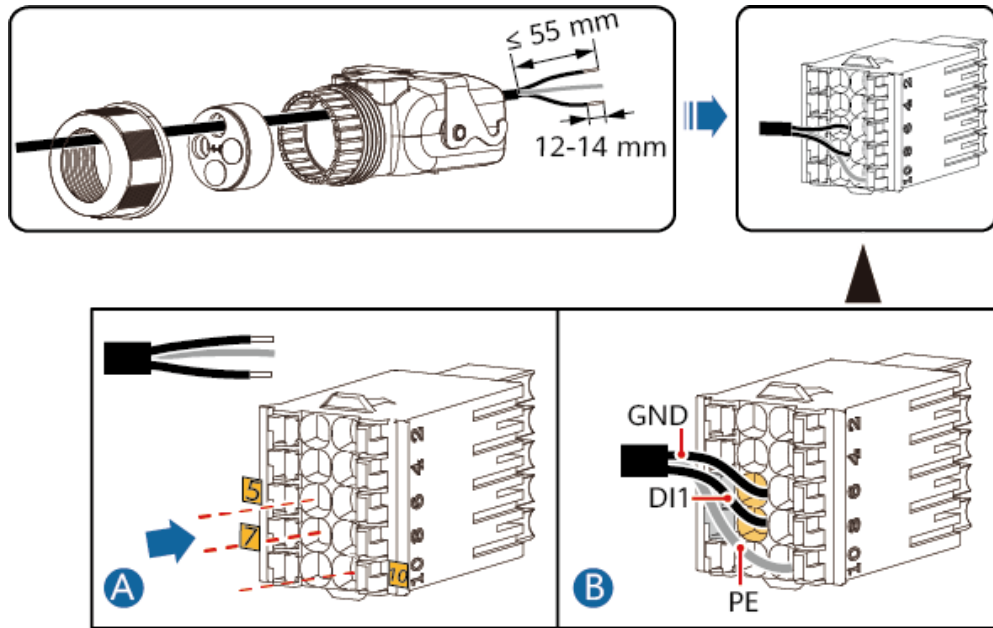
Procedure

Step 1 Connect the signal cable to the signal cable connector block.

NOTICE

- The rapid shutdown function is supported only if optimizers are configured for all PV modules.
- Connect terminals 5 and 7 to a switch. The switch is turned on by default. When the switch is turned off, a rapid shutdown is triggered.

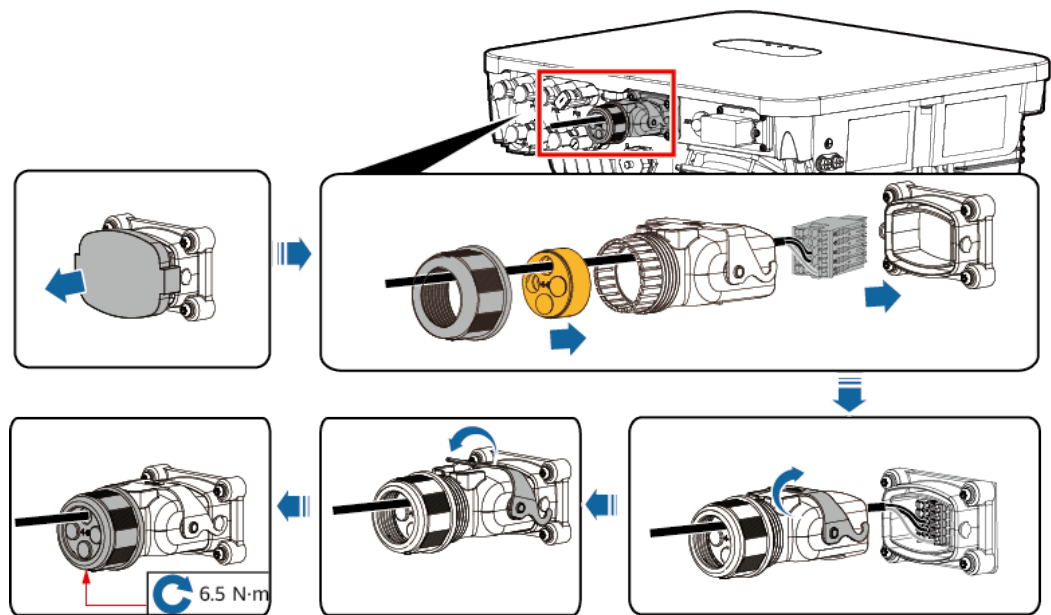
Figure 5-23 Installing the cable



IH09I40005

Step 2 Connect the signal cable connector to the COM port.

Figure 5-24 Securing the signal cable connector



IH09H40004

----End

5.8 (Optional) Installing the Smart Dongle and Anti-theft Components

NOTE

If the Smart Dongle is used, you need to install anti-theft components after installing the Smart Dongle.

WLAN-FE Smart Dongle (FE Communication)

You are advised to use a CAT 5E outdoor shielded network cable (outer diameter < 9 mm; internal resistance ≤ 1.5 ohms/10 m) and shielded RJ45 connectors.

Figure 5-25 Installing a WLAN-FE Smart Dongle (FE communication)

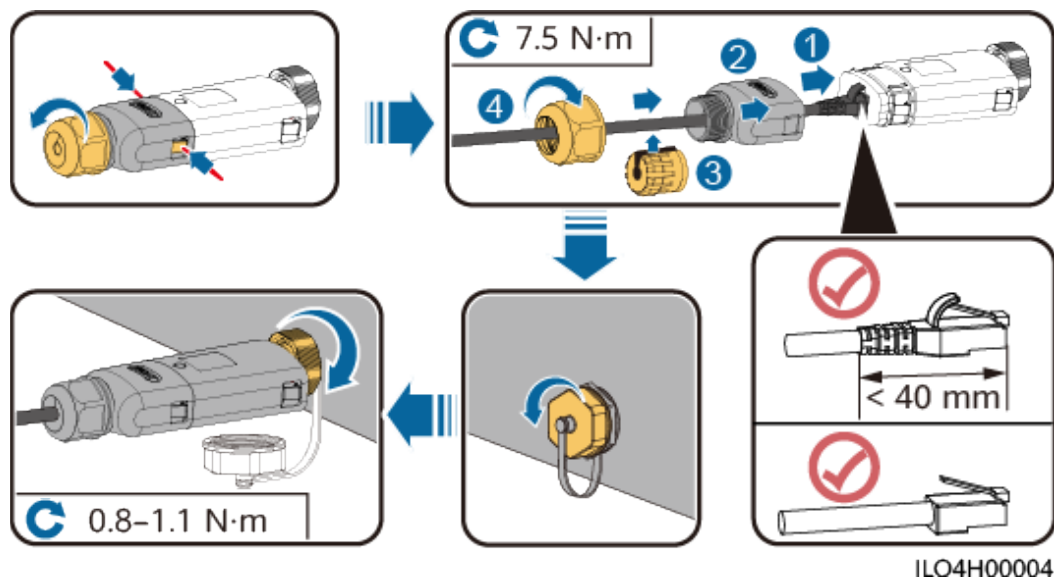
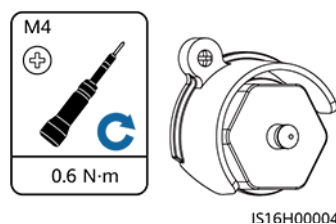


Figure 5-26 Installing anti-theft components for the Smart Dongle



5.9 Installing an Antenna

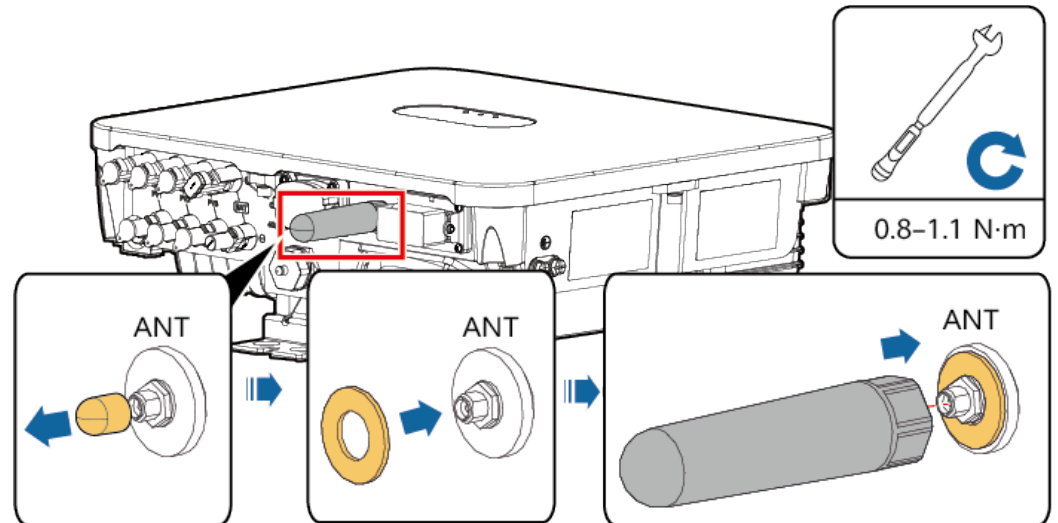
Procedure

Step 1 Remove the watertight cap from the ANT port.

Step 2 Install the washer to the ANT port on the device.

Step 3 Install the WLAN antenna.**NOTICE**

Ensure that the WLAN antenna is installed securely.

Figure 5-27 Installing a WLAN antenna

IH09H00006

----End

6 Check Before Power-On

Table 6-1 Installation checklist

No.	Check Item	Acceptance Criteria
1	Inverter installation	The inverter is installed correctly, securely, and reliably.
2	Smart Dongle	The Smart Dongle is installed correctly and securely.
3	Cable layout	Cables are routed properly as required by the customer.
4	Cable tie	Cable ties are secured evenly and no burr exists.
5	Grounding	The ground cable is connected correctly, securely, and reliably.
6	Turn off the switches	The DC SWITCH and all the switches connected to the inverter are set to OFF .
7	Cable connections	The AC output power cable, DC input power cable, and signal cable are connected correctly, securely, and reliably.
8	Unused terminals and ports	Unused terminals and ports are locked by watertight caps.
9	Installation environment	The installation space is proper, and the installation environment is clean and tidy, without foreign matter.

7 Power-On and Commissioning

7.1 Powering On the Inverter

Precautions

NOTICE

Before the equipment is put into operation for the first time, ensure that the parameters are set correctly by professional personnel. Incorrect parameter settings may result in noncompliance with local grid connection requirements and affect the normal operations of the equipment.

NOTICE

- If the DC power supply is connected but the AC power supply is disconnected, the inverter will report a **Grid Loss** alarm. The inverter can start properly only after the power grid recovers.
 - If the AC power supply is connected but the battery is not connected, the inverter reports a **Battery Abnormal** alarm.
-

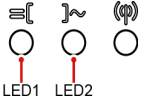
Procedure

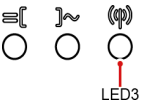
- Step 1** If a battery connects to the battery port, turn on the battery switch.
- Step 2** At the AC switch between the inverter and the power grid, use a multimeter to measure the grid voltage and ensure that the voltage is within the allowed operating voltage range of the inverter. If the voltage is not in the allowed range, check the circuits.
- Step 3** Turn on the AC switch between the inverter and the power grid.
- Step 4** Turn on the DC switch (if any) between the PV strings and the inverter.
- Step 5** Remove the DC switch padlock from the inverter.

Step 6 Set the DC switch on the inverter to ON.

Step 7 Observe the LED indicators to check the status of the inverter.

Table 7-1 LED indicators

Category	Status		Description
Running indication 	LED1	LED2	–
	Steady green	Steady green	The inverter is running in grid-tied state.
	Blinking green slowly (on for 1s and off for 1s)	Off	The DC is on and the AC is off.
	Blinking green slowly (on for 1s and off for 1s)	Blinking green slowly (on for 1s and off for 1s)	Both the DC and AC are on, and the inverter is off-grid.
	Off	Blinking green slowly (on for 1s and off for 1s)	The DC is off and the AC is on.
	Steady yellow	Steady yellow	The inverter is running in off-grid state.
	Blinking yellow slowly	Off	The DC is on and the inverter has no output in off-grid state.
	Blinking yellow slowly	Blinking yellow slowly	The inverter is in off-grid overload state.
	Off	Off	Both the DC and AC are off.
	Blinking red fast (on for 0.2s and off for 0.2s)	–	There is a DC environmental alarm, such as String Voltage High , String Reverse Connection , or Low Insulation Resistance .
	–	Blinking red fast (on for 0.2s and off for 0.2s)	There is an AC environmental alarm, such as Grid Undervoltage , Grid Overvoltage , Grid Overfrequency , or Grid Underfrequency .
	Steady red	Steady red	A fault exists.

Category	Status	Description		
Communi- cation indication 	LED3	-		
	Blinking green fast (on for 0.2s and then off for 0.2s)	Communication is in progress.		
	Blinking green slowly (on for 1s and off for 1s)	A mobile phone is connected to the inverter.		
	Off	There is no communication.		
Device replaceme- nt indication	LED1	LED2	LED3	-
	Steady red	Steady red	Steady red	The inverter hardware is faulty and needs to be replaced.

NOTE

If off-grid overload occurs, the inverter indicators LED1 and LED2 will blink orange slowly. You need to reduce the power of the off-grid loads, and manually clear the alarm or wait for the inverter to automatically recover. The inverter attempts to restart every 5 minutes. After three failed attempts, the retry interval changes to 2 hours. If the inverter is standby in off-grid mode, check the inverter alarms and rectify the faults.

----End

7.2 Creating a Plant

7.2.1 Downloading the HiSolar App

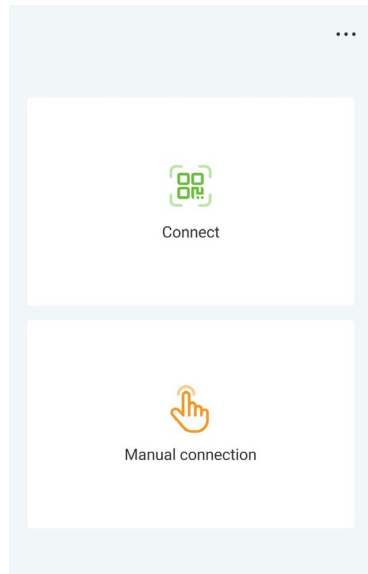
Search for **HiSolar** on Google Play and download the latest installation package.

You can use the app to perform local maintenance operations, such as device commissioning, parameter setting, log export, and software upgrade.

7.2.2 Connecting to the Inverter

Step 1 You can connect to the inverter by scanning the QR code or choosing manual connection on the app.

- Scanning the QR code: Tap **Connect** and scan the QR code of the inverter to automatically connect to the inverter.
- Manual connection: Tap **Manual connection**, select **WLAN connection**, and connect to the corresponding WLAN hotspot in the WLAN list on the app. The initial name of the WLAN hotspot is the inverter SN, and obtain the initial password for connecting to the solar inverter WLAN from the label on the side of the solar inverter.



Step 2 Log in as an **Installer**. Set the login password upon the first login.

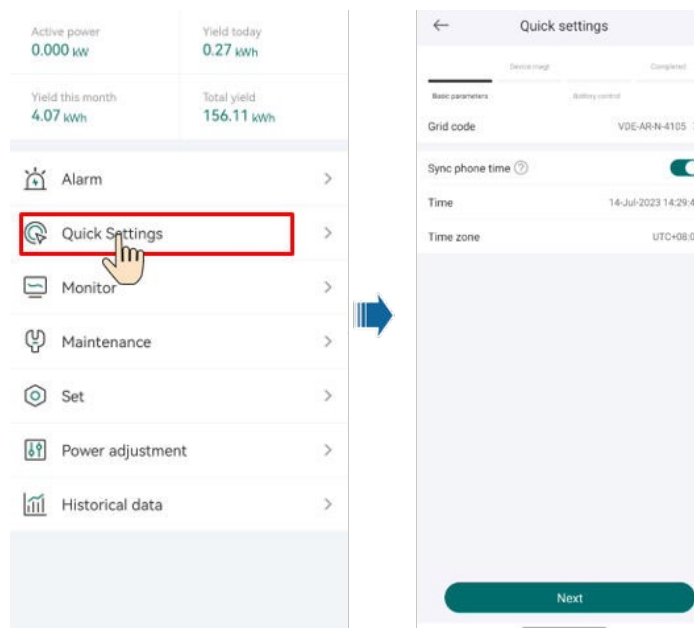
NOTICE

To ensure account security, protect the password by changing it periodically, and keep it secure.

----End

7.2.3 Quick Settings

Set parameters as prompted on the **Quick settings** screen.



 NOTE

The user interface (UI) varies with associated devices. The preceding UI screenshots are for reference only.

7.2.4 What Should I Do If the Device Is Disconnected from the App When I Switch the Local Commissioning Screen to the Background?

During local commissioning, you may need to switch the app to the background (for example, uploading an upgrade package, uploading a photo, or scanning a QR code for WLAN connection). When you switch back to the app screen, a message is displayed, indicating that the device is disconnected from the app and you need to log in again.

Solution

Tap **Settings** of your mobile phone, keep the **Hisolar app** running in the background.

7.3 Parameters Settings

Set inverter parameters. Connect to the solar inverter WLAN and log in to the device commissioning screen as the **installer** user.

NOTICE

- If the mobile phone is directly connected to the inverter, the visible distance between the inverter and the mobile phone must be less than 3 m when a built-in antenna is used and less than 50 m when an external antenna is used to ensure the communication quality between the App and the inverter. The distances are for reference only and may vary with mobile phones and shielding conditions.
 - When connecting the inverter to the WLAN over a router, ensure that the mobile phone and inverter are in the WLAN coverage of the router and the inverter is connected to the router.
 - The router supports WLAN (IEEE 802.11 b/g/n, 2.4 GHz) and the WLAN signal reaches the inverter.
 - The WPA, WPA2, or WPA/WPA2 encryption mode is recommended for routers. Enterprise-level encryption is not supported (for example, public hotspots requiring authentication such as airport WLAN). WEP and WPA TKIP are not recommended because these two encryption modes have serious security defects. If the access fails in WEP mode, log in to the router and change the encryption mode of the router to WPA2 or WPA/WPA2.
-

NOTE

- Obtain the initial password for connecting to the solar inverter WLAN from the label on the side of the solar inverter.
- Set the password at the first login. To ensure account security, change the password periodically and keep the new password in mind. Not changing the initial password may cause password disclosure. A password left unchanged for a long period of time may be stolen or cracked. If a password is lost, devices cannot be accessed. In these cases, the user is liable for any loss caused to the PV plant.
- When you access the **device commission** screen of the inverter for the first time, you need to manually set the login password because the inverter does not have an initial login password.

7.3.1 Energy Control

7.3.1.1 Grid-tied Point Control

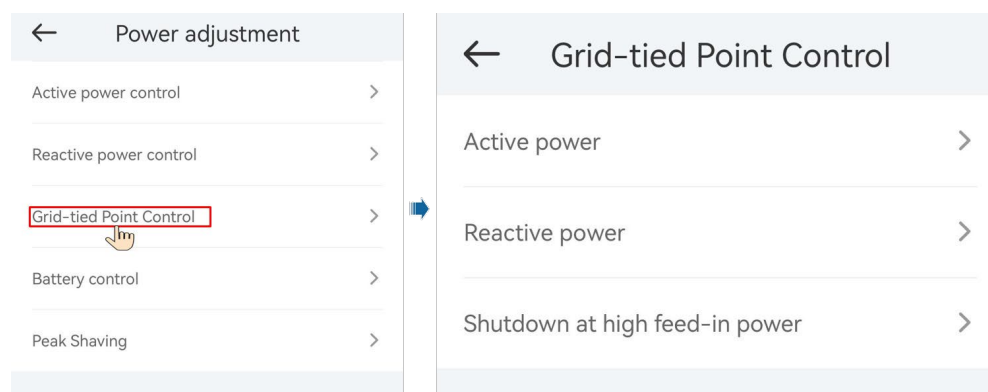
Function

Limits or reduces the output power of the PV power system to ensure that the output power is within the power deviation limit.

Procedure

Step 1 On the home screen, choose **Power adjustment > Grid-tied point control**.

Figure 7-1 Grid-tied point control



Parameter Name			Description
Active power	Unlimited	-	If this parameter is set to Unlimited , the output power of the inverter is not limited and the inverter can connect to the power grid at the rated power.

Parameter Name		Description
Grid connected with zero power	Closed-loop controller	<ul style="list-style-type: none"> If multiple inverters are cascaded, set this parameter to SDongle. If there is only one inverter, set this parameter to Inverter.
	Limitation mode	Total power indicates export limitation of the total power at the grid-tied point.
	Power adjustment interval	Specifies the shortest interval for a single anti-backfeeding adjustment.
	Power raising threshold	Specifies the dead zone for adjusting the inverter output power. If the power fluctuation is within the power control hysteresis, the power is not adjusted.
	Communication disconnection fail-safe	In the inverter anti-backfeeding scenario, if this parameter is set to Enable , the inverter will derate according to the active power derating percentage when the communication between the inverter and the Smart Dongle is disconnected for a period longer than Communication disconnection detection time .
	Communication disconnection detection time	Specifies the time for determining the communication disconnection between the inverter and the Dongle. This parameter is displayed when Communication disconnection fail-safe is set to Enable .

Parameter Name		Description
	Active power threshold when communication fails	Specifies the derating value of the inverter active power by percentage. If the Smart Dongle does not detect any meter data or the communication between the Smart Dongle and the inverter is disconnected, the Smart Dongle delivers the derating value of the inverter active power by percentage.
Limited feed-in (kW)	Closed-loop controller	<ul style="list-style-type: none"> • If multiple inverters are cascaded, set this parameter to SDongle. • If there is only one inverter, set this parameter to Inverter.
	Limitation mode	Total power indicates export limitation of the total power at the grid-tied point.
	Maximum grid feed-in power	Specifies the maximum active power transmitted from the grid-tied point to the power grid.
	Power adjustment interval	Specifies the shortest interval for a single anti-backfeeding adjustment.
	Power raising threshold	Specifies the dead zone for adjusting the inverter output power. If the power fluctuation is within the power control hysteresis, the power is not adjusted.
	Communication disconnection fail-safe	In the inverter anti-backfeeding scenario, if this parameter is set to Enable , the inverter will derate according to the active power derating percentage when the communication between the inverter and the Smart Dongle is disconnected for a period longer than Communication disconnection detection time .

Parameter Name		Description
	Communication disconnection detection time	Specifies the time for determining the communication disconnection between the inverter and the Dongle. This parameter is displayed when Communication disconnection fail-safe is set to Enable .
	Active power threshold when communication fails	Specifies the derating value of the inverter active power by percentage. If the Smart Dongle does not detect any meter data or the communication between the Smart Dongle and the inverter is disconnected, the Smart Dongle delivers the derating value of the inverter active power by percentage.
Power-limited grid connected (%)	Closed-loop controller	<ul style="list-style-type: none"> • If multiple inverters are cascaded, set this parameter to SDongle. • If there is only one inverter, set this parameter to Inverter.
	Limitation mode	Total power indicates export limitation of the total power at the grid-tied point.
	PV plant capacity	Specifies the total maximum active power in the inverter cascading scenario.
	Maximum grid feed-in power	Specifies the percentage of the maximum active power of the grid-tied point to the PV plant capacity.
	Power adjustment interval	Specifies the shortest interval for a single anti-backfeeding adjustment.
	Power raising threshold	Specifies the dead zone for adjusting the inverter output power. If the power fluctuation is within the power control hysteresis, the power is not adjusted.

Parameter Name		Description
	Communication disconnection fail-safe	In the inverter anti-backfeeding scenario, if this parameter is set to Enable , the inverter will derate according to the active power derating percentage when the communication between the inverter and the Smart Dongle is disconnected for a period longer than Communication disconnection detection time .
	Communication disconnection detection time	Specifies the time for determining the communication disconnection between the inverter and the Dongle. This parameter is displayed when Communication disconnection fail-safe is set to Enable .
	Active power threshold when communication fails	Specifies the derating value of the inverter active power by percentage. If the Smart Dongle does not detect any meter data or the communication between the Smart Dongle and the inverter is disconnected, the Smart Dongle delivers the derating value of the inverter active power by percentage.
Shutdown at high feed-in power ^a	Shutdown at high feed-in power	<ul style="list-style-type: none"> • The default value is Disable. • If this parameter is set to Enable, the inverter shuts down for protection when the grid-connection point power exceeds the threshold and remains in this condition for the specified time threshold.

Parameter Name		Description
	Upper feed-in power threshold for inverter shutdown (kW)	<ul style="list-style-type: none"> The default value is 0. This parameter specifies the power threshold of the grid-connection point for triggering inverter shutdown.
	High feed-in power duration threshold for triggering inverter shutdown (s)	<p>The default value is 20. This parameter specifies the duration threshold of high feed-in power for triggering inverter shutdown.</p> <ul style="list-style-type: none"> When High feed-in power duration threshold for triggering inverter shutdown is set to 5, Shutdown at high feed-in power takes precedence. When High feed-in power duration threshold for triggering inverter shutdown is set to 20, Grid connection with limited power takes precedence (when Active power control is set to Grid connection with limited power).
Note a: This parameter is supported only for the AS4777 grid code.		

----End

7.3.1.2 Apparent Power Control on the Inverter Output Side

On the home screen, tap **Set > Power adjustment** to set inverter parameters.

Parameter	Description	Value Range
Maximum apparent power (kVA)	Specifies the output upper threshold for the maximum apparent power to adapt to the capacity requirements of standard and customized inverters.	[Maximum active power, S_{max}]

Parameter	Description	Value Range
Maximum active power (kW)	Specifies the output upper threshold for the maximum active power to adapt to different market requirements.	[0.1, P _{max}]

NOTE

The lower threshold for the maximum apparent power is the maximum active power. To lower the maximum apparent power, lower the maximum active power first.

7.3.1.3 Battery Control

Prerequisites

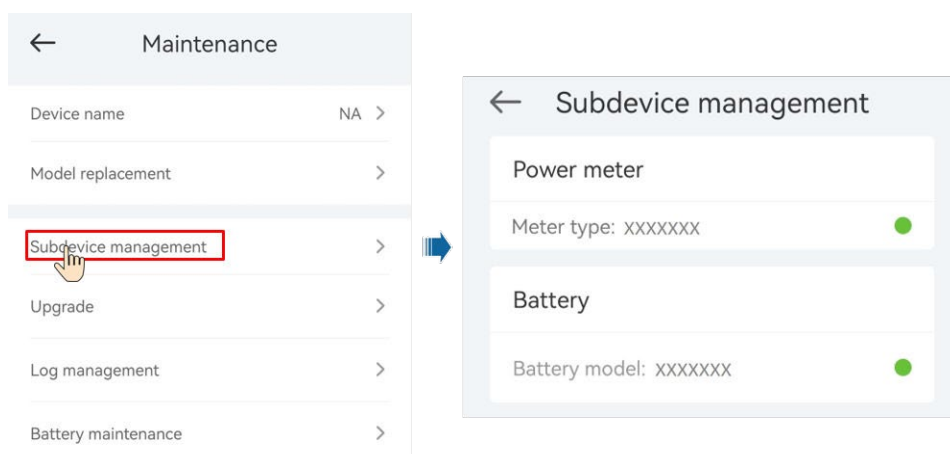
The screenshots in this chapter are taken in the Hisolar 1.0.0.4 App. The App is being updated. The actual screens may vary.

Function

When the inverter connects to a battery, add the battery and set battery parameters.

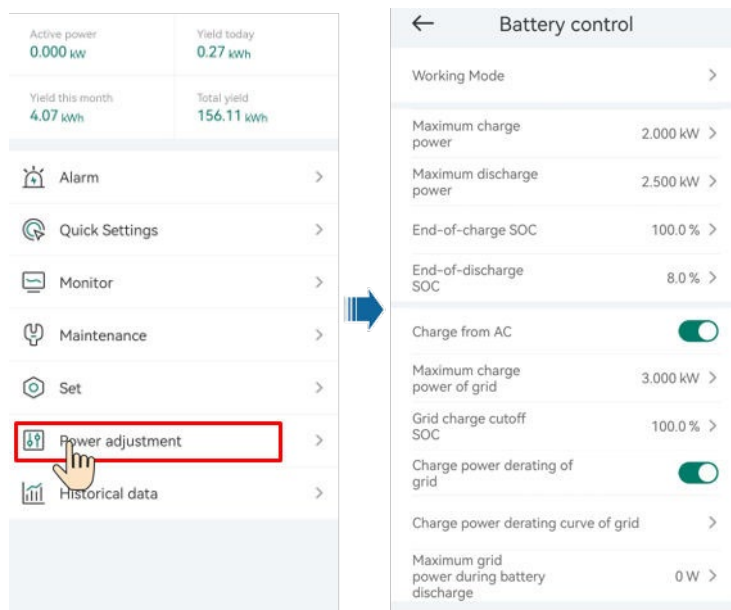
Adding a Battery

To add a battery, choose **Maintenance** > **Subdevice management** on the home screen.



Parameters Settings

On the home screen, choose **Power adjustment** > **Battery control**, and set the battery parameters and working mode.



Parameter	Description	Value Range
Working mode	For details, see the description on the App screen.	<ul style="list-style-type: none"> Maximum self-consumption TOU Fully fed to grid
Maximum charge power (kW)	Retain this parameter to the maximum charge power. Additional configuration is not required.	<ul style="list-style-type: none"> Charge: [0, Maximum charge power]
Maximum discharge power (kW)	Retain this parameter to the maximum discharge power. Additional configuration is not required.	<ul style="list-style-type: none"> Discharge: [0, Maximum discharge power]
End-of-charge SOC	Set the charge cutoff capacity.	[90%-100%]
End-of-discharge SOC	Set the discharge cutoff capacity.	[0%-20%] (When no PV module is configured or the PV modules have no voltage for 24 hours, the minimum value is 15%.)
Charge from AC	If Charge from AC function is disabled by default, comply with the grid charge requirements stipulated in local laws and regulations when this function is enabled.	<ul style="list-style-type: none"> Disable Enable

Parameter	Description	Value Range
Maximum charge power of grid	Set the maximum power for charging from the grid.	[0, Maximum charge power of grid]
Grid charge cutoff SOC	Set the grid charge cutoff SOC.	[20%, 100%]

7.3.1.4 Peak Shaving

Prerequisites

The screenshots in this section are captured from the HiSolar app 1.0.0.4. The actual screens may vary with app updates.

Description

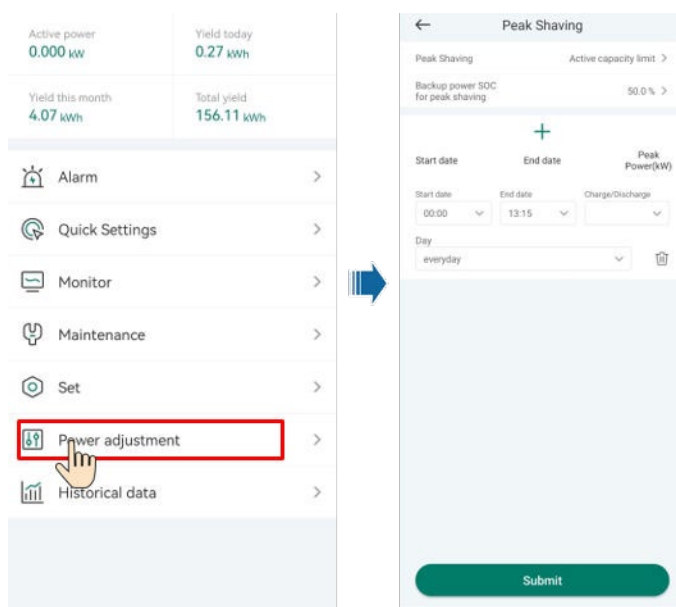
If the inverter connects to an ESS and the ESS working mode is set to **Maximum self-consumption** or **TOU**, you can set capacity control parameters.

Parameter Settings

On the home screen, choose **Power adjustment > Peak Shaving** and set peak shaving parameters.

NOTE

- The peak shaving function is unavailable when the energy storage working mode is set to **Fully fed to grid**.
- When peak shaving has been enabled, you must first disable peak shaving and then set the energy storage working mode to **Fully fed to grid**.



Parameter	Description	Range
Peak Shaving	<ol style="list-style-type: none"> Before enabling Peak Shaving, set Charge from AC to Enable. Before disabling Charge from AC, set Peak Shaving to Disable. 	<ul style="list-style-type: none"> Disable Active capacity limit
Backup power SOC for peak shaving	The value of this parameter affects the peak shaving capability. A larger value indicates stronger peak shaving capability.	(8.0, 100.0] Backup power SOC for peak shaving > Backup power SOC (when BackUp is enabled) > End-of-discharge SOC
Start date	<ul style="list-style-type: none"> Set the peak power range based on the start time and end time. The peak power is configured based on electricity prices in different time segments. You are advised to set the peak power to a low value when the electricity price is high. A maximum of 14 time segments are allowed. 	-
End date		
Peak power (kW)		[0.000, 1000.000]

7.3.2 AFCI

Function

If PV modules or cables are not properly connected or damaged, electric arcs may occur, which may cause fire. Inverters provide unique arc detection in compliance with UL 1699B-2018 to ensure the safety of users' lives and property.

This function is enabled by default. The inverter automatically detects arc faults. To disable this function, log in to the HiSolar App, on the home screen, choose **Set** > **Feature parameters**, and disable **AFCI**.

NOTE

The AFCI function works only with SUN2000-450W-P2, and SUN2000-600W-P optimizers or ordinary PV modules, but does not support third-party optimizers or intelligent PV modules.

Clearing Alarms

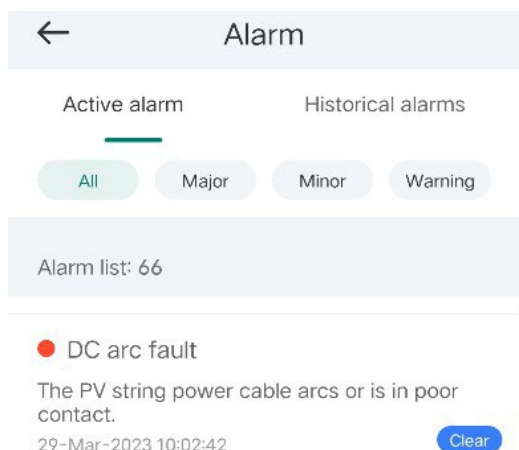
The AFCI function involves the **DC arc fault** alarm.

The inverter has the AFCI alarm automatic clearance mechanism. If an alarm is triggered for less than five times within 24 hours, the inverter automatically clears the alarm. If the alarm is triggered for five times or more within 24 hours, the

inverter locks for protection. You need to manually clear the alarm on the inverter so that it can work properly.

You can manually clear the alarm as follows:

Log in to the HiSolar App and on the home screen, connect and log in to the inverter that generates the AFCI alarm, tap **Alarm**, and tap **Clear** on the right of the **DC arc fault** alarm to clear the alarm.



7.3.3 DRM

Function

According to AS/NZS 4777.2:2020+A1:2021, solar inverters need to support the function of demand response mode (DRM), and DRM0 is a mandatory requirement.

This function is disabled by default.

Inverter connected to the NMS directly/Smart Dongle networking

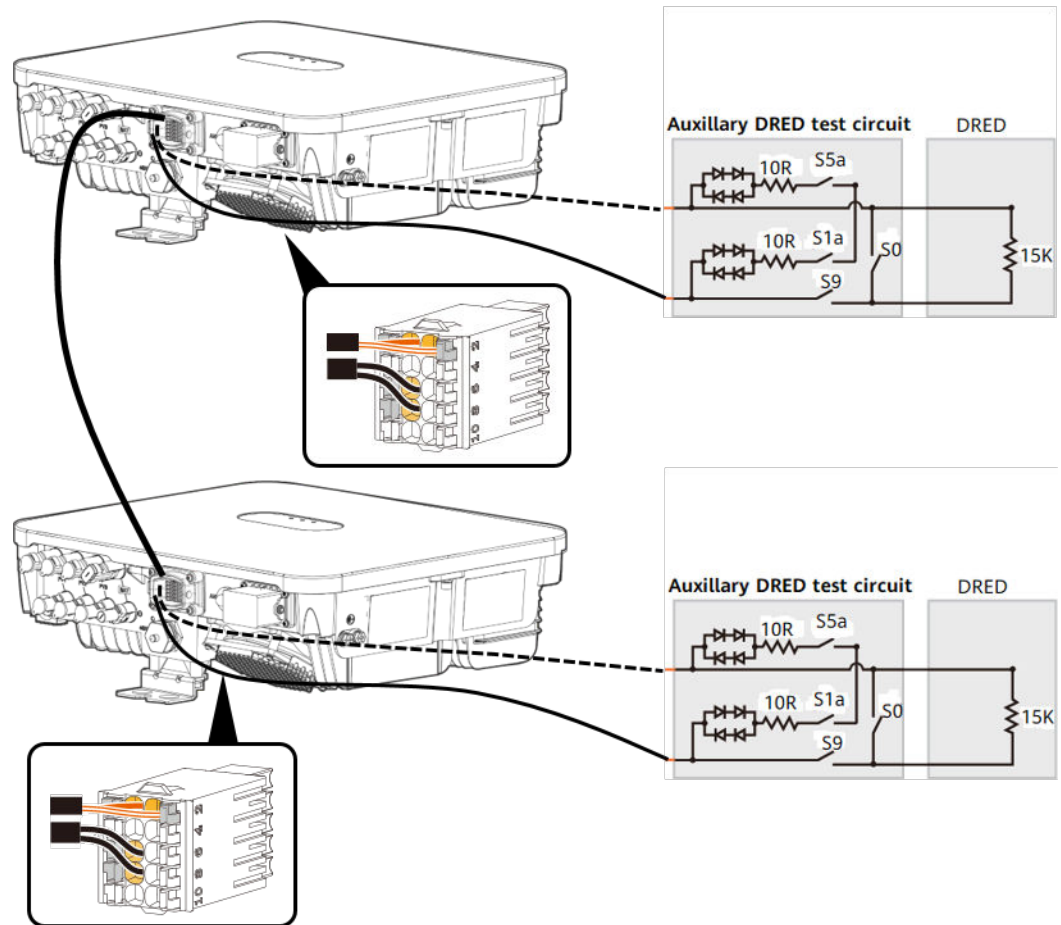


Table 7-2 DRM requirements

Mode	Port on the inverter	Requirements
DRM0	DI1 and GND of the COM port	<ul style="list-style-type: none"> When switches S0 and S9 are switched on, the solar inverter should be turned off. When switch S0 is switched off, and switch S9 is switched on, the solar inverter should be grid-tied.

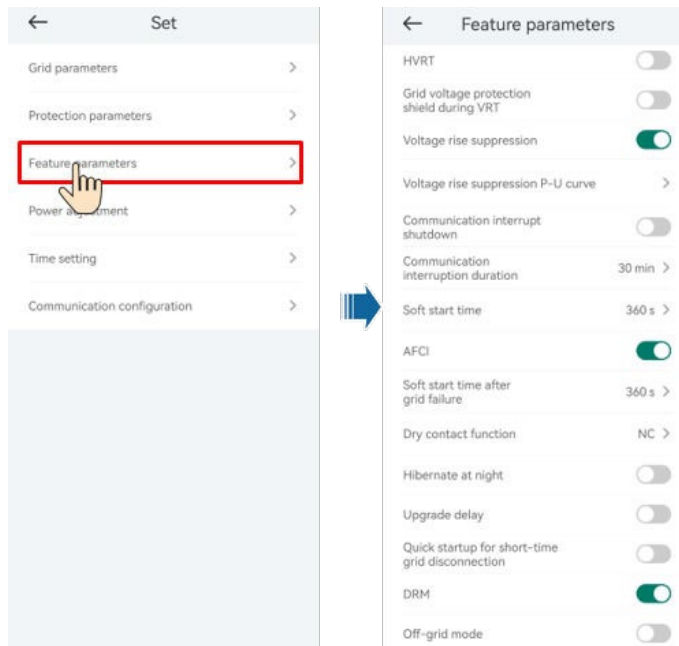
NOTE

The demand response enabling device (DRED) is a power grid dispatch device.

Procedure

Step 1 On the home page, choose **Set > Feature parameters**.

Step 2 Set DRM to .



----End

8 System Maintenance

8.1 Routine Maintenance

To ensure that the inverter can operate properly for a long term, you are advised to perform routine maintenance on it as described in this section.

 **CAUTION**

Power off the system before cleaning the system, connecting cables, and checking grounding reliability.

Table 8-1 Maintenance checklist

Check Item	Check Method	Maintenance Interval
System cleanliness	Check periodically whether the heat sinks are blocked or dirty.	Once every 6 to 12 months
Cleanness of air intake and exhaust vents	Check periodically whether there is dust or foreign objects at the air intake and exhaust vents.	Power off the inverter and remove dust and foreign objects. If necessary, remove the baffle plates from the air intake and exhaust vents for cleaning. Once every 6 to 12 months (or once every 3 to 6 months based on the actual dust conditions in the environment)

Check Item	Check Method	Maintenance Interval
Fan	Check whether the fan generates abnormal noise during operation.	Remove foreign objects from the fan. If the abnormal noise persists, replace the fan. For details, see 8.5 Replacing a Fan . Once every 6 to 12 months
System running status	<ul style="list-style-type: none"> • Check whether the inverter is damaged or deformed. • Check whether the inverter generates abnormal sound during operation. • Check whether all inverter parameters are correctly set during operation. 	Once every 6 months
Electrical connection	<ul style="list-style-type: none"> • Check whether cables are disconnected or loose. • Check whether cables are damaged, especially whether the cable sheath that contacts a metal surface is damaged. 	6 months after the first commissioning and once every 6 to 12 months after that
Grounding reliability	Check whether the PE cable is securely connected.	6 months after the first commissioning and once every 6 to 12 months after that
Sealing	Check whether all terminals and ports are properly sealed.	Once a year

8.2 System Power-Off

Precautions



WARNING

- After the system is powered off, the inverter is still energized and hot, which may cause electric shocks or burns. Therefore, wait for at least 5 minutes and wear insulated gloves before working on the inverter.
- Before maintaining the optimizer and PV strings, power off the system by following the procedure. Otherwise, electric shocks may occur because the PV strings are energized.

Procedure

Step 1 Send a shutdown command on the app.

Step 2 Set the **DC SWITCH** to **OFF**.

Step 3 Install the DC switch padlock.

Step 4 Turn off the AC switch between the inverter and the power grid.

Step 5 Turn off the DC switch between the inverter and PV strings.

Step 6 (Optional) Turn off the battery switch between the inverter and the battery.

----End

8.3 Troubleshooting



NOTE

Contact your dealer if all failure analysis procedures listed below are completed and the fault still exists.

Alarm severities are defined as follows:

- **Major:** The inverter shuts down or some functions are abnormal due to a fault.
- **Minor:** Some components of the inverter are faulty but the system can still connect to the grid and generate power.
- **Warning:** The inverter functions normally, but its output power decreases due to external factors.

Table 8-2 Common alarms and troubleshooting measures

Alarm ID	Alarm Name	Alarm Severity	Possible Causes	Troubleshooting
2001	String Voltage High	Major	<p>The PV array is not properly configured. Excessive PV modules are connected in series to the PV string, and therefore the open-circuit voltage exceeds the maximum operating voltage of the device.</p> <p>Cause ID = 1, 2, 3</p> <ul style="list-style-type: none"> ● 1: The PV1 input voltage is high. ● 2: The PV2 input voltage is high. ● 3: The PV3 input voltage is high. 	<ol style="list-style-type: none"> 1. If the DC switch is on, check the serial connection configurations of the PV string.(1) If the maximum open-circuit voltage of the PV string is higher than the maximum input voltage, contact your vendor or technical support. (2) If the maximum open-circuit voltage of the PV string is lower than the maximum input voltage, ensure that the maximum open-circuit voltage of the PV string is lower than or equal to the maximum operating voltage of the device. After the PV array is correctly configured, the device alarm is automatically cleared. 2. If the DC switch is off, contact your vendor or technical support.The following is the mapping between PV strings and alarm cause IDs: IDs 1-<i>n</i> correspond to PV strings 1-<i>n</i> respectively.
2002	DC Arc Fault	Major	<p>The PV string power cables arc or are in poor contact.</p> <ul style="list-style-type: none"> ● Cause ID 1: PV1 DC arc fault ● Cause ID 2: PV2 DC arc fault ● Cause ID 3: PV3 DC arc fault 	Check whether the string cables arc or are in poor contact.
2003	DC Arc Fault	Major	<p>The PV string power cables arc or are in poor contact. (String-level precise detection)</p> <ul style="list-style-type: none"> ● Cause ID 1: PV string 1 ● Cause ID 2: PV string 2 ● Cause ID 3: PV string 3 	Check whether the PV string cables arc or are in poor contact.

Alarm ID	Alarm Name	Alarm Severity	Possible Causes	Troubleshooting
2011	String Reversed	Major	<p>The PV string is reversely connected.</p> <p>Cause ID = 1, 2, 3</p> <ul style="list-style-type: none"> ● 1: PV1 is reversely connected. ● 2: PV2 is reversely connected. ● 3: PV3 is reversely connected. 	<ol style="list-style-type: none"> 1. Check whether the PV string is reversely connected to the device. If yes, wait until the PV string current decreases below 0.5 A, set the DC SWITCH to OFF, and adjust the PV string polarity. 2. If the fault persists, reset the device on the local maintenance app or WebUI of the upper-layer controller. Alternatively, you can turn off the AC and DC switches, wait for 5 minutes, and then turn on the AC and DC switches.
2021	AFCI Check Failure	Major	<p>The AFCI check fails.</p> <p>Cause ID = 1, 2</p> <ul style="list-style-type: none"> ● 1: The AFCI check circuit is abnormal. ● 2: The AFCI circuit is faulty. 	<p>Turn off the AC output switch and DC input switch, and then turn them on after 5 minutes. If the fault persists, contact your dealer or technical support.</p>
2032	Grid Failure	Major	<p>Cause ID = 1</p> <ul style="list-style-type: none"> ● The power grid experiences an outage. ● The AC circuit is disconnected or the AC circuit breaker is OFF. 	<ol style="list-style-type: none"> 1. Check the AC voltage. 2. Check whether the AC circuit is disconnected or the AC circuit breaker is OFF.

Alarm ID	Alarm Name	Alarm Severity	Possible Causes	Troubleshooting
2033	Grid Undervoltage	Major	<p>Cause ID = 1</p> <p>The grid voltage is below the lower threshold or the low voltage duration has lasted for more than the value specified by low voltage ride-through (LVRT).</p>	<ol style="list-style-type: none"> 1. If the alarm occurs occasionally, the power grid may be abnormal temporarily. The device automatically recovers after detecting that the power grid becomes normal. 2. If the alarm occurs frequently, check whether the power grid voltage is within the allowed range. If no, contact the local power operator. If yes, modify the grid undervoltage protection threshold through the mobile app with the consent of the local power operator. 3. If the fault persists for a long time, check the connection between the AC switch and the output power cable.
2034	Grid Overvoltage	Major	<p>Cause ID = 1</p> <p>The grid voltage exceeds the higher threshold or the high voltage has lasted for more than the value specified by high voltage ride-through (HVRT).</p>	<ol style="list-style-type: none"> 1. If the alarm occurs occasionally, the power grid may be abnormal temporarily. The device automatically recovers after detecting that the power grid becomes normal. 2. If the alarm occurs frequently, check whether the power grid voltage is within the allowed range. If no, contact the local power operator. If yes, modify the grid overvoltage protection threshold through the mobile app with the consent of the local power operator. 3. Check whether the peak voltage of the power grid is too high. If the fault persists and cannot be rectified for a long time, contact the power operator.

Alarm ID	Alarm Name	Alarm Severity	Possible Causes	Troubleshooting
2036	Grid Overfrequency	Major	Cause ID = 1 Power grid exception: The actual power grid frequency is higher than the standard requirement for the local power grid.	<ol style="list-style-type: none"> 1. If the alarm occurs occasionally, the power grid may be abnormal temporarily. The device automatically recovers after detecting that the power grid becomes normal. 2. If the alarm occurs frequently, check whether the power grid frequency is within the allowed range. If no, contact the local power operator. If yes, modify the grid overfrequency protection threshold through the mobile app with the consent of the local power operator.
2037	Grid Underfrequency	Major	Cause ID = 1 Power grid exception: The actual power grid frequency is lower than the standard requirement for the local power grid.	<ol style="list-style-type: none"> 1. If the alarm occurs occasionally, the power grid may be abnormal temporarily. The device automatically recovers after detecting that the power grid becomes normal. 2. If the alarm occurs frequently, check whether the power grid frequency is within the allowed range. If no, contact the local power operator. If yes, modify the grid underfrequency protection threshold through the mobile app with the consent of the local power operator.
2038	Unstable Grid Frequency	Major	Cause ID = 1 Power grid exception: The actual grid frequency change rate does not comply with the local power grid standard.	<ol style="list-style-type: none"> 1. If the alarm occurs occasionally, the power grid may be abnormal temporarily. The device automatically recovers after detecting that the power grid becomes normal. 2. If the alarm occurs frequently, check whether the power grid frequency is within the allowed range. If no, contact the local power operator.

Alarm ID	Alarm Name	Alarm Severity	Possible Causes	Troubleshooting
2039	AC Overcurrent	Major	<p>Cause ID = 1</p> <p>The grid experiences a dramatic voltage drop or is short-circuited. As a result, the transient AC current of the device exceeds the upper threshold and triggers protection.</p>	<ol style="list-style-type: none"> 1. The device detects its external working conditions in real time. After the fault is rectified, the device automatically recovers. 2. If the alarm occurs frequently and affects the energy yield of the power plant, check whether the output is short-circuited. If the fault persists, contact your dealer or technical support.
2040	DC Component Overhigh	Major	<p>Cause ID = 1</p> <p>The DC component in the AC current exceeds the upper threshold.</p>	<ol style="list-style-type: none"> 1. The device detects its external working conditions in real time. After the fault is rectified, the device automatically recovers. 2. If the alarm occurs frequently, contact your dealer or technical support.
2051	Abnormal Residual Current	Major	<p>Cause ID = 1</p> <p>The insulation impedance of the input side to PE decreases when the device is operating.</p>	<ol style="list-style-type: none"> 1. If the alarm occurs occasionally, the external circuit may be abnormal temporarily. The inverter automatically recovers after the fault is rectified. 2. If the alarm occurs frequently or persists, check whether the impedance between the PV string and the ground is too low.

Alarm ID	Alarm Name	Alarm Severity	Possible Causes	Troubleshooting
2062	Low Insulation Resistance	Major	Cause ID = 1 <ul style="list-style-type: none"> • A short circuit occurs between the PV array and the ground. • The ambient air of the PV array is damp and the insulation between the PV array and the ground is poor. 	<ol style="list-style-type: none"> 1. Set Insulation resistance protection to the minimum value and restart the inverter. 2. Check that the PE cable of the device is correctly connected. 3. Check the output impedance of the PV array to ground. If there is a short circuit or lack of insulation, rectify it. Current insulation resistance: x MΩ, possible short circuit position: x%. The short circuit position is valid for a single PV string. If there are multiple PV strings, check the PV strings one by one. For details, see 8.6 Locating Insulation Resistance Faults.
2063	Overtemperature	Minor	Cause ID = 1 <ul style="list-style-type: none"> • The device is installed in a place with poor ventilation. • The ambient temperature is higher than the upper threshold. • The device is not working properly. 	<ul style="list-style-type: none"> • Check the ventilation and ambient temperature of the device installation position. • If the ventilation is poor or the ambient temperature exceeds the upper threshold, improve the ventilation and heat dissipation. • If the ventilation and ambient temperature both meet requirements, contact your dealer or technical support.

Alarm ID	Alarm Name	Alarm Severity	Possible Causes	Troubleshooting
2064	Device Fault	Major	<p>A major fault has occurred on the internal circuit of the device.</p> <p>Cause ID = 1-12</p> <ul style="list-style-type: none"> ● 1: The Boost input is short-circuited. ● 2: The Boost input experiences overcurrent. ● 3: The control circuit is faulty. ● 4: The inverter circuit is abnormal. ● 5: The residual current sensor is faulty. ● 6: The temperature detection fails. ● 7: EEPROM read/write fails. ● 8: The auxiliary power supply is abnormal. ● 9: The grid-tied relay is abnormal. ● 10: The DC bus experiences overvoltage. ● 11: The DC bus experiences undervoltage. ● 12: The DC bus experiences voltage imbalance. 	<p>Contact your vendor or technical support, wait until the PV string current decreases to below 0.5 A, and then turn off all DC switches.</p>

Alarm ID	Alarm Name	Alarm Severity	Possible Causes	Troubleshooting
2065	Upgrade Failed or Version Mismatch	Minor	<p>The upgrade does not complete normally.</p> <p>Cause ID = 1-4, 7</p> <ul style="list-style-type: none"> • 1: The software and hardware of the main controller do not match. • 2: The main and auxiliary controller software versions do not match. • 3: The monitoring and power controller software versions do not match. • 4: The upgrade fails. • 7: The optimizer upgrade fails. 	<ol style="list-style-type: none"> 1. Perform an upgrade again. 2. If the upgrade fails for multiple times, contact your dealer or technical support.
61440	Monitoring Unit Faulty	Minor	<p>Cause ID = 1</p> <ul style="list-style-type: none"> • The flash memory is insufficient. • The flash memory has bad sectors. 	<p>Turn off the AC output switch and DC input switch, and then turn them on after 5 minutes. If the fault persists, replace the monitoring board or contact your dealer technical support.</p>
2067	Faulty Power Collector	Major	<p>Cause ID = 1</p> <p>The power meter is disconnected.</p>	<ol style="list-style-type: none"> 1. Check that the configured power meter model is the same as the actual model. 2. Check that the communications parameters for the smart power sensors are the same as the device RS485 configurations. 3. Check whether the smart power sensor is powered on and whether the RS485 communications cable is connected.

Alarm ID	Alarm Name	Alarm Severity	Possible Causes	Troubleshooting
2068	Battery Abnormal	Minor	<ul style="list-style-type: none"> The battery is faulty. Communication with the battery is interrupted. The battery circuit breaker is disconnected during the running of the inverter. <p>Cause ID = 1-5</p> <ul style="list-style-type: none"> 1: The battery communication is abnormal. 2: The battery port experiences overcurrent. 3: The battery enabling cable is not properly connected. 4: The battery port voltage is abnormal. 5: The battery cable connection is abnormal. 	<ol style="list-style-type: none"> If the battery fault indicator is steady on or blinking, contact the battery supplier. Check that the battery is enabled, the communications cable and power cable are connected correctly, and the communication parameters are consistent with the RS485 configuration on the device. Check that the auxiliary power switch on the battery is set to ON. Send a shutdown command on the app. Turn off the AC output switch, DC input switch, and battery switch. Then turn on the battery switch, AC output switch, and DC input switch in sequence after 5 minutes. If the fault persists, contact your dealer or technical support.
2070	Active Islanding	Major	<p>Cause ID = 1</p> <p>When the power grid experiences an AC power outage, the device detects islanding proactively.</p>	<p>Check that the voltage at the grid connection point of the device is normal.</p>
2077	Off-grid output overload	Major	<p>Cause ID = 1, 2</p> <ul style="list-style-type: none"> The output is overloaded or short-circuited. The irradiance or battery level is low. 	<ol style="list-style-type: none"> Check whether the device output is short-circuited. Check whether the device load configuration exceeds the rated value. If the irradiance or battery level is low, remove some loads. After the preceding problems are resolved, manually clear the alarm.

Alarm ID	Alarm Name	Alarm Severity	Possible Causes	Troubleshooting
2080	Abnormal PV Module Configuration	Major	<p>PV module configuration does not meet requirements, or the PV module output is reversely connected or short-circuited.</p> <p>Cause ID = 2, 3, 6, 7, 8, 9, 12, 13</p> <ul style="list-style-type: none"> ● 2: The PV string power or the number of optimizers connected in series in a PV string exceeds the upper threshold. ● 3: The number of optimizers connected in series in a PV string is less than the lower threshold, the PV string output is reversely connected, or the output of some optimizers in the PV string is reversely connected. ● 6: Under the same MPPT, the number of optimizers connected in series in PV strings connected in parallel is different, or the output of some optimizers in PV strings is reversely connected. ● 7: The optimizer installation position is changed, or PV strings are combined or exchanged. ● 8: The sunlight is weak or changes abnormally. ● 9: In partial configuration scenarios, the PV string voltage exceeds the device input voltage specifications. ● 12: 	<p>Check whether the total number of PV modules, number of PV modules in a string, and number of PV strings meet requirements and whether the PV module output is reversely connected.</p> <ul style="list-style-type: none"> ● ID2: Check whether the PV string power or the number of PV modules connected in series in the PV string exceeds the upper threshold. ● ID3: <ol style="list-style-type: none"> 1. Check whether the number of optimizers connected in series in the PV string is below the lower threshold. 2. Check whether the PV string output is reversely connected. 3. Check whether the PV string output is disconnected. 4. Check whether the optimizer output extension cable is correct (positive connector at one end and negative connector at the other). ● ID6: <ol style="list-style-type: none"> 1. Check whether the number of optimizers connected in series in the PV strings connected in parallel under the same MPPT is the same. 2. Check whether the optimizer output extension cable is correct (positive connector at one end and negative connector at the other). ● ID7: When the sunlight is normal, perform the optimizer search function again. ● ID8: When the sunlight is normal, perform the optimizer search function again.

Alarm ID	Alarm Name	Alarm Severity	Possible Causes	Troubleshooting
			<ol style="list-style-type: none"> 1. Check whether the number of optimizers connected in series in the PV string is below the lower threshold. 2. The string output terminals are in reverse polarity. 3. Disconnection has occurred on the string. 4. The output terminals of some optimizers in the PV string are connected in reverse polarity. <ul style="list-style-type: none"> • 13: <ol style="list-style-type: none"> 1. Partial optimizer configuration is not supported. 2. The number of optimizers connected in series exceeds the upper threshold. 	<ul style="list-style-type: none"> • ID9: Calculate the PV string voltage based on the number of PV modules in the PV string and check whether the PV string voltage exceeds the upper threshold of the inverter input voltage. • ID12: Check the string cable connection. For details, see the optimizer installation quick guide. <ol style="list-style-type: none"> 1. Check whether the number of optimizers connected in series in the PV string is below the lower threshold. 2. Check whether the PV string output is in reverse polarity. 3. Check whether the PV string output is disconnected. 4. Check whether the optimizer output extension cable (if any) is prepared correctly (positive connector at one end and negative connector at the other). • ID13: <ol style="list-style-type: none"> 1. Rectify the optimizer configuration. 2. Check that the number of optimizers connected in series is within the upper threshold.
2081	Optimizer Fault	Warning	Cause ID = 1 An optimizer is faulty.	<ol style="list-style-type: none"> 1. View the fault details on the optimizer information page. 2. Contact your dealer or technical support to replace the optimizer.

Alarm ID	Alarm Name	Alarm Severity	Possible Causes	Troubleshooting
2086	External fan abnormal	Major	Cause ID = 1 The external fan is short-circuited, the power supply is insufficient, or the air channel is blocked.	<ol style="list-style-type: none"> 1. Shut down the fan, turn off the DC switch, check whether the fan blades are damaged, and clear the foreign matter around the fan. 2. Reinstall the fan, turn on the DC switch, and wait for the inverter to start. If the fault persists after 15 minutes, replace the external fan.

8.4 Replacing an Inverter

Step 1 Remove the inverter.

1. Power off the system. For details, see [8.2 System Power-Off](#).
2. Disconnect all cables from the inverter, including signal cables, DC input power cables, battery cables, AC output power cables, and PE cables.
3. Remove the WLAN antenna or Smart Dongle from the inverter.
4. Remove the inverter from the mounting bracket.
5. Remove the mounting bracket.

Step 2 Pack the inverter.

- If the original packaging is available, put the inverter inside it and then seal it using adhesive tape.
- If the original packaging is unavailable, put the inverter inside a suitable hard cardboard box and seal it properly.

Step 3 Dispose of the inverter.

If the inverter reaches the end of its service life, dispose of it according to local regulations for the disposal of electrical equipment.

Step 4 Install a new inverter.

----End

8.5 Replacing a Fan

CAUTION

- Before replacing a fan, power off the inverter.
- When replacing a fan, use insulated tools and wear PPE.
- Currently, there are two types of fan hand shields. The method for replacing a fan is the same.

Procedure

Step 1 Remove the inverter from the mounting bracket.

Step 2 Remove the fan cover, disconnect fan cables, and remove the faulty fan.

Figure 8-1 Removing the faulty fan(Type 1)

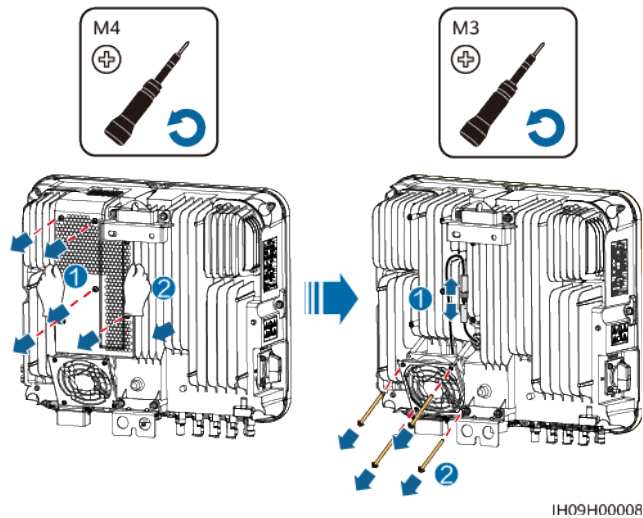
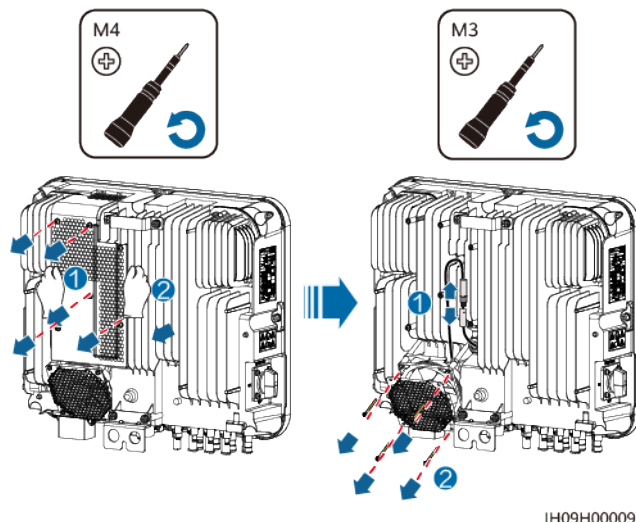


Figure 8-2 Removing the faulty fan(Type 2)



Step 3 Install a new fan, connect and bind the cables, and install the fan cover.

----End

8.6 Locating Insulation Resistance Faults

If the ground resistance of a PV string connected to the inverter is too low, the inverter generates a **Low insulation resistance** alarm.

The possible causes are as follows:

- A short circuit has occurred between the PV array and the ground.
- The ambient air of the PV array is damp and the insulation between the PV array and the ground is poor.

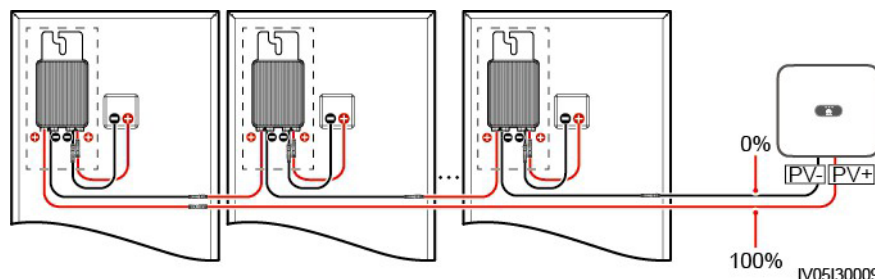
After the **Low insulation resistance** alarm is reported by the inverter, insulation resistance fault location is automatically triggered. If the fault location is successful, the location information is displayed on the **Alarm details** screen of the **Low insulation resistance** alarm on the HiSolar app.

Log in to the HiSolar app, choose **Alarm > Active alarm**, select **Low insulation resistance** to enter the **Alarm details** screen.

NOTE

- The positive and negative terminals of a PV string are connected to the PV+ and PV- terminals of the inverter, respectively. The 0% position corresponds to the PV- terminal, and the 100% position corresponds to the PV+ terminal. Other percentages indicate that the fault occurs on a PV module or cable in the PV string.
- Possible fault position = Total number of PV modules in a PV string x Percentage of possible short-circuit positions. For example, if a PV string consists of 14 PV modules and the percentage of the possible short-circuit position is 34%, the possible fault position is 4.76 (14 x 34%), indicating that the fault is located near PV module 4, including the adjacent PV modules and their cables. The inverter has a detection precision of ± 1 PV module.
- MPPT1 that may be faulty corresponds to PV1, MPPT2 that may be faulty corresponds to PV2, and MPPT3 that may be faulty corresponds to PV3. Perform the following steps to locate and rectify the fault.
- When a non-short-circuit fault occurs, the possible short-circuit percentage is not displayed. If the insulation resistance is greater than $0.001 \text{ M}\Omega$, the fault is not related to short circuit. Check all PV modules in the faulty PV string one by one to locate and rectify the fault.

Figure 8-3 Percentage of short-circuit positions



Procedure

NOTICE

If the irradiance or the PV string voltage is too high, the insulation resistance fault location may fail. In this case, the fault location status on the **Alarm details** screen is **Conditions not met**. Perform the following steps to connect PV strings to the inverter one by one to locate the fault. If the system is not configured with any optimizer, skip the corresponding optimizer operations.

- Step 1** Ensure that the AC connections are normal. Log in to the HiSolar app, choose **Maintenance > Inverter ON/OFF** on the home screen, and send a shutdown command. Set **DC SWITCH** to **OFF**.
- Step 2** Connect one PV string to the inverter, and set **DC SWITCH** to **ON**. If the inverter status is **Shutdown: Command**, log in to the app, choose **Maintenance > Inverter ON/OFF** on the home screen, and send a startup command.
- Step 3** Choose **Alarm** on the home screen, enter the **Active alarm** screen, and check whether a **Low insulation resistance** alarm is reported.
- If no **Low insulation resistance** alarm is reported 1 minute after the DC side is powered on, choose **Maintenance > Inverter ON/OFF** on the home screen, and send a shutdown command. Set **DC SWITCH** to **OFF**. Go to **Step 2** and check rest of the PV strings one by one.
 - If a **Low insulation resistance** alarm is reported 1 minute after the DC side is powered on, check the percentage of possible short-circuit positions on the **Alarm details** screen and calculate the location of the possible faulty PV module based on the percentage. Then go to **Step 4**.
- Step 4** Log in to the app, choose **Maintenance > Inverter ON/OFF** on the home screen, and send a shutdown command. Set **DC SWITCH** to **OFF**. Check whether the connectors or DC power cables between the optimizer and PV module, between adjacent PV modules, or between adjacent optimizers on the possible fault position are damaged.
- If yes, replace the damaged connectors or DC power cables, and then set **DC SWITCH** to **ON**. If the inverter status is **Shutdown: Command**, choose **Maintenance > Inverter ON/OFF**, and send a startup command. View alarm information.
 - If no **Low insulation resistance** alarm is reported 1 minute after the DC side is powered on, troubleshoot the insulation resistance fault of the PV string. Log in to the app, choose **Maintenance > Inverter ON/OFF** on the home screen, and send a shutdown command. Set **DC SWITCH** to **OFF**. Go to **Step 2** and check rest of the PV strings one by one. Then, go to **Step 8**.
 - If the DC side is powered on 1 minute later, the **Low insulation resistance** alarm is still reported. Log in to the app, choose **Maintenance > Inverter ON/OFF** on the home screen, and send a shutdown command. Set **DC SWITCH** to **OFF** and go to **Step 5**.
 - If no, go to **Step 5**.
- Step 5** Disconnect the possible faulty PV module and the paired optimizer from the PV string, and use a DC extension cable with an MC4 connector to connect the PV module or optimizer adjacent to the possible faulty PV module. Set **DC SWITCH** to **ON**. If the inverter status is **Shutdown: Command**, choose **Maintenance > Inverter ON/OFF** on the home screen, and send a startup command. View alarm information.
- If no **Low insulation resistance** alarm is reported 1 minute after the DC side is powered on, the fault occurred on the disconnected PV module and optimizer. Choose **Maintenance > Inverter ON/OFF**, send a shutdown command, and set **DC SWITCH** to **OFF**. Go to **Step 7**.
 - If the **Low insulation resistance** alarm is reported 1 minute after the DC side is powered on, the fault did not occur on the disconnected PV module and optimizer. Go to **Step 6**.

Step 6 Log in to the app, choose **Maintenance > Inverter ON/OFF** on the home screen, and send a shutdown command. Set **DC SWITCH** to **OFF**, reconnect the disconnected PV module and optimizer, and repeat **Step 5** to check the PV modules and optimizers adjacent to the possible fault location.

Step 7 Determine the position of the ground insulation fault:

- Disconnect the possible faulty PV module from the optimizer.
- Connect the possible faulty optimizer to the PV string.
- Set **DC SWITCH** to **ON**. If the inverter status is **Shutdown: Command**, choose **Maintenance > Inverter ON/OFF**, and send a startup command. View alarm information.
 - If no **Low insulation resistance** alarm is reported 1 minute after the DC side is powered on, the fault is on the possible faulty PV module.
 - If the **Low insulation resistance** alarm is reported 1 minute after the DC side is powered on, the fault is on the possible faulty optimizer.
- Log in to the app, choose **Maintenance > Inverter ON/OFF** on the home screen, and send a shutdown command. Set **DC SWITCH** to **OFF**, replace the faulty component, and complete troubleshooting the insulation resistance fault. Go to **Step 2** and check rest of the PV strings one by one. Then, go to **Step 8**.

Step 8 Set **DC SWITCH** to **ON**. If the inverter status is **Shutdown: Command**, choose **Maintenance > Inverter ON/OFF**, and send a startup command.

----End

9 Technical Specifications

Efficiency

Technical Specifications	IS-HYB-5000HC-IPH	IS-HYB-8000-1PH	IS-HYB-10000-1PH
Maximum efficiency	97.9%	98.1%	98.1%
European efficiency	97.2%	97.5%	97.5%

Input

Technical Specifications	IS-HYB-5000HC-IPH	IS-HYB-8000-1PH	IS-HYB-10000-1PH
Recommended maximum input DC power*	12500W*	20000W*	25000W*
Maximum input voltage ^[1]	600 V		
Maximum input current per MPPT	16 A		
Maximum short-circuit current per MPPT	20 A		
Minimum startup voltage	50 V		
MPPT voltage range	40-560 V		

Technical Specifications	IS-HYB-5000HC-IPH	IS-HYB-8000-1PH	IS-HYB-10000-1PH
Rated input voltage	360 V		
Maximum number of inputs ^[2]	3		
Number of MPPT circuits	3		
Maximum battery input voltage	600 V DC		
Battery voltage range	350-600 V DC		
Maximum battery current	25 A		
Battery type	Li-ion		
<p>Note [1]: The maximum input voltage is the maximum DC input voltage that the inverter can withstand. If the input voltage exceeds this value, the inverter may be damaged.</p> <p>Note [2]: Do not connect only one PV string to the inverter.</p>			

On-Grid Output

Technical Specifications	IS-HYB-5000HC-IPH	IS-HYB-8000-1PH	IS-HYB-10000-1PH
Rated output power	4999 W	8000 W	9999 W 10,000 W (NZ)
Maximum apparent power	4999 VA	8800 VA	9999 VA 10,000 VA (NZ)
Maximum active power (cosφ = 1)	4999 W	8800 W	9999 W 10,000 W (NZ)
A.C Nominal Voltage	220 V/230 V/240 V~		
Reverse Charge Current	22.7 A		
Maximum output voltage at long-term operation	Refer to the local power grid standards.		

Technical Specifications	IS-HYB-5000HC-IPH	IS-HYB-8000-1PH	IS-HYB-10000-1PH
Rated output current	22.72A/220 V 21.73/230 V 20.83/240 V	36.4 A/220 V 34.8 A/230 V 33.3 A/240 V	45.5 A/220 V 43.5 A/230 V 41.7 A/240 V
Maximum output current	22.72A	40.0 A	45.5 A
Output voltage frequency	50 Hz/60 Hz		
Maximum output fault current	75.3 A	113.12 A	128.55 A
Power factor	0.8 leading..... 0.8 lagging		
Output DC component (DCI)	< 0.25% of the rated output		
Maximum total harmonic distortion (AC THDi)	≤ 3% (rated conditions)		

Off-Grid Output

Technical Specifications	IS-HYB-5000HC-IPH	IS-HYB-8000-1PH	IS-HYB-10000-1PH
Rated apparent power	4999 VA	8000 VA	10000 VA
Maximum apparent power	110%, 60s		

Protection

Technical Specifications	IS-HYB-5000HC-IPH	IS-HYB-8000-1PH	IS-HYB-10000-1PH
Overvoltage category	DC II/AC III		
Input DC switch	Supported		
Anti-islanding protection	Supported		

Technical Specifications	IS-HYB-5000HC-IPH	IS-HYB-8000-1PH	IS-HYB-10000-1PH
Output overcurrent protection	Supported		
Input reverse connection protection	Supported		
Battery reverse charging from grid	Supported		
PV string fault detection	Supported		
DC surge protection	Supported		
AC surge protection	Supported		
Insulation resistance detection	Supported		
AFCI	Supported		
Residual current monitoring unit (RCMU)	Supported		

Display and Communication

Technical Specifications	IS-HYB-5000HC-IPH	IS-HYB-8000-1PH	IS-HYB-10000-1PH
Display	LED indicators		
WLAN-FE Dongle	Optional		
RS485 communication	Supported		
Built-in WLAN	Supported		

General Specifications

	IS-HYB-5000HC-1PH	IS-HYB-8000-1PH	IS-HYB-10000-1PH
Dimensions (W x H x D, with hanging kits)	425 mm x 376.5 mm x 150 mm		
Technical Specifications			
Net weight	≤ 15 kg		
Noise	< 29 dB (typical working condition)	< 29 dB (typical working condition)	< 40 dB (typical working condition)
Operating temperature	-25°C to +60°C		
Relative humidity	0-100% RH		
Cooling mode	Natural Convection	Natural Convection	Smart Air Cooling
Maximum operating altitude	4000 m (derated when the altitude is greater than 2000 m)		
Storage temperature	-40°C to +70°C		
IP rating	IP66		
Topology	Transformerless		
Country of Manufacture	China		

Wireless Communication Parameters

Specifications	Inverter Built-in WiFi	WLAN-FE Smart Dongle
Frequency	2400-2483.5 MHz	2400-2483.5 MHz
Protocol standard	WLAN 802.11b/g/n	WLAN 802.11b/g/n
Bandwidth	20 MHz/40 MHz (optional)	20 MHz/40 MHz (optional)
Maximum transmit power	≤ 20 dBm EIRP	≤ 20 dBm EIRP

A Grid Codes

NOTE

The grid codes are subject to change. The listed codes are for reference only.

Table A-I Grid codes

No.	Grid Code	Description	IS-HYB-5000HC-IPH IS-HYB-8000-IPH IS-HYB-10000-IPH (+NZ)
1	RD1699/661	Spain low-voltage power grid	Supported
2	PO12.3	Spain low-voltage power grid	Supported
3	NTS	Spain power grid	Supported
4	EN50549-LV	Netherlands, Luxembourg, Türkiye, Slovakia, Ireland, Norway, Portugal, and Hungary	Supported
5	EN50549-SE	Sweden low-voltage power grid	Supported
6	ANRE	Romania power grid	Supported
7	ABNT NBR 16149	Brazil power grid	Supported
8	AUSTRALIA-AS4777_A-LV230	Australia power grid	Supported
9	AUSTRALIA-AS4777_B-LV230	Australia power grid	Supported
10	AUSTRALIA-AS4777_C-LV230	Australia power grid	Supported
11	AUSTRALIA-AS4777_NZ-LV230	Australia power grid	Supported

No.	Grid Code	Description	IS-HYB-5000HC-IPH IS-HYB-8000-IPH IS-HYB-10000-IPH (+NZ)
12	G99-TYPEA-LV	UK G99_TypeA_LV power grid	Supported
13	TAI-PEA	Thailand grid-connection standard	Supported
14	TAI-MEA	Thailand grid-connection standard	Supported
15	TAIPOWER	Taiwan Power low-voltage power grid	Supported
16	HONGKONG	Hong Kong low-voltage power grid	Supported
17	SINGAPORE	Singapore low-voltage power grid	Supported
18	Philippines	Philippines low-voltage power grid	Supported
19	NRS-097-2-1	South Africa power grid standard	Supported
20	IEC 61727	IEC 61727 low-voltage grid-connection (50 Hz)	Supported
21	IEC 61727 - 60 Hz	IEC 61727 low-voltage grid-connection (60 Hz)	Supported
22	Custom (50 Hz)	Reserved	Supported
23	Custom (60 Hz)	Reserved	Supported

B Baud Rate Negotiation

Baud rate negotiation increases the communications rate between the inverter and devices such as batteries and power meters, and between the inverter and the Smart Dongles, solving or relieving communication congestion.

- During device search in a new plant, the system automatically negotiates the baud rate.
- When replacing or adding inverters, batteries, power meters, the Smart Dongle at an existing plant, you need to manually send local commands on the Hisolar app to reset the baud rate between devices and negotiate a higher rate.

NOTE

Users can send the baud rate negotiation commands on the HiSolar app in three networking modes: Inverter connected to the NMS directly and Smart Dongle networking.

Table B-I Manual baud rate negotiation on the app

Networking Mode	Scenario	Operation
Inverter connected to the NMS directly	Replacing the inverter	1. Use the Hisolar app to locally scan the QR code to connect to the inverter.
	Replacing or adding an RS485_2 device (such as a battery or power meter)	2. Access the Communication configuration screen, choose RS485 > Baud Rate Negotiation > RS485_2 > Baud Rate Negotiation , and tap 9600 and Negotiate a higher rate .

Networking Mode	Scenario	Operation
Smart Dongle networking	Replacing the Smart Dongle	<ol style="list-style-type: none"> 1. Use the Hisolar app to locally scan the QR code to connect to the inverter. 2. Access the Communication configuration screen, choose RS485 > Baud Rate Negotiation > RS485_I > Baud Rate Negotiation, and tap 9600 and Negotiate a higher rate.
	Replacing or adding an inverter	<ol style="list-style-type: none"> 1. Use the Hisolar app to locally scan the QR code to connect to the inverter. 2. Access the Communication configuration screen, choose RS485 > Baud Rate Negotiation > RS485_I > Baud Rate Negotiation, and tap 9600 and Negotiate a higher rate. 3. Access the Communication configuration screen, choose RS485 > Baud Rate Negotiation > RS485_2 > Baud Rate Negotiation, and tap 9600 and Negotiate a higher rate.
	Replacing or adding an RS485_2 device (such as a battery or power meter)	<ol style="list-style-type: none"> 1. Use the Hisolar app to locally scan the QR code to connect to the inverter. 2. Access the Communication configuration screen, choose RS485 > Baud Rate Negotiation > RS485_2 > Baud Rate Negotiation, and tap 9600 and Negotiate a higher rate.



Troubleshooting

If manual baud rate negotiation fails, refer to the following troubleshooting measures.

Table B-2 Troubleshooting measures

Scenario	Troubleshooting
Negotiation failed	<ol style="list-style-type: none"> 1. Check whether the device cables are connected properly. If no, connect the device cables correctly. 2. Check whether service operations such as upgrade and log export are performed on the management system. If yes, perform baud rate negotiation again after such operations are complete. 3. To replace an RS485_2 device (such as a battery or power meter), choose Maintenance > Subdevice management on the home screen, touch and hold the replaced RS485_2 device to delete it. 4. Perform baud rate negotiation again. 5. When replacing or adding an inverter or an RS485_2 device (such as a battery or power meter), if you tap Negotiate a higher rate and a message "Negotiation failed. The southbound device does not support the rate." is displayed, it indicates that the device does not support baud rate negotiation. In this case, you only need to tap 9600. 6. If the fault persists, contact your vendor.

C Resetting Password

Step 1 Check that the AC and DC sides of the inverter are both powered on, and indicators  and  are steady green or blinking slowly for more than 3 minutes.

Step 2 Complete the following operations within 4 minutes:


Turn off the AC switch and set **DC SWITCH** to **OFF** at the bottom of the inverter. If the inverter is connected to a battery, turn off the battery switch. Wait until all LED indicators on the inverter panel turn off.

Turn on the AC switch and set **DC SWITCH** to **ON**. Wait about 90s and check that indicator  is blinking green slowly.

Turn off the AC switch and set **DC SWITCH** to **OFF**. Wait until all LED indicators on the inverter panel turn off.

Turn on the AC switch and set **DC SWITCH** to **ON**. Wait until all LED indicators on the inverter panel blink and then turn off after 30s.

Step 3 Reset the password within 10 minutes. (If no operation is performed within 10 minutes, all parameters of the inverter remain unchanged.)

1. Wait until indicator  blinks green slowly.
2. Connect to the app using the initial WLAN hotspot name (SSID) and initial password (PSW), which can be obtained from the label on the side of the inverter.
3. On the login screen, set a new password and log in to the app.

Step 4 Set router and management system parameters to implement remote management.

----End

D Acronyms and Abbreviations

A	
AC	alternating current
D	
DC	direct current
DCI	direct current identification
F	
FRT	fault ride through
H	
HVRT	high voltage ride-through
I	
ID	identifier
L	
LED	light emitting diode
LVRT	low voltage ride-through
M	
MAC	Media Access Control
MPPT	maximum power point tracking
P	
PE	protective earthing
a	

PV	photovoltaic
R	
RCMU	residual current monitoring unit
RH	relative humidity
S	
SN	serial number